

2024  
COLLECTION



**Gallotti&Radice**

**Gallotti&Radice**

2024  
COLLECTION

MILANO DESIGN WEEK 2024

2024 COLLECTION

CRAFTSMANSHIP

MATERIALITY

LIGHTNESS

NATURAL TONES

DURABILITY

2024 COLLECTION

MDW 20

24 MI



---

PRODUCT INDEX

---

TABLES

MOLECOLA  
SELCE-T  
RE-VERRE TABLE

CHAIRS

H2O  
0414 - 10° ANNIVERSARY

BENCHES AND POUFS

SENSEI BENCH

SOFAS AND ARMCHAIRS

CLOUD INFINITY | New module  
CLOUD CHAISE LONGUE  
STAMI LOVESEAT  
STAMI SOFA  
STAMI SOFA MODULARE  
LILAS MOSAÏQUE | New modules

TABLES

CHANTAL | New finishes  
RE-VERRE | New finishes  
SENSEI | New dimensions and finishes

CONSOLE

SENSEI CONSOLE | New finishes

LIGHTS

BOLLE STELO  
BOLLE FAMILY - 10° ANNIVERSARY

STORAGE UNIT

GASTONE | New finishes  
GASTONE LOW | New finishes  
HIDE&SEEK DOOR  
SODA | New finishes  
STAMI SIDEBOARD

NIGHT

HIDE&SEEK MINI  
SUNRISE

DESKS AND VANITY

SENSEI DESK

ACCESSORIES AND DECORATIVE OBJECTS

ATO  
IPERBOREA

2024 COLLECTION

# LIVING 1

SALONE DEL  
MOBILE.MILANO  
2024





LIVING 1

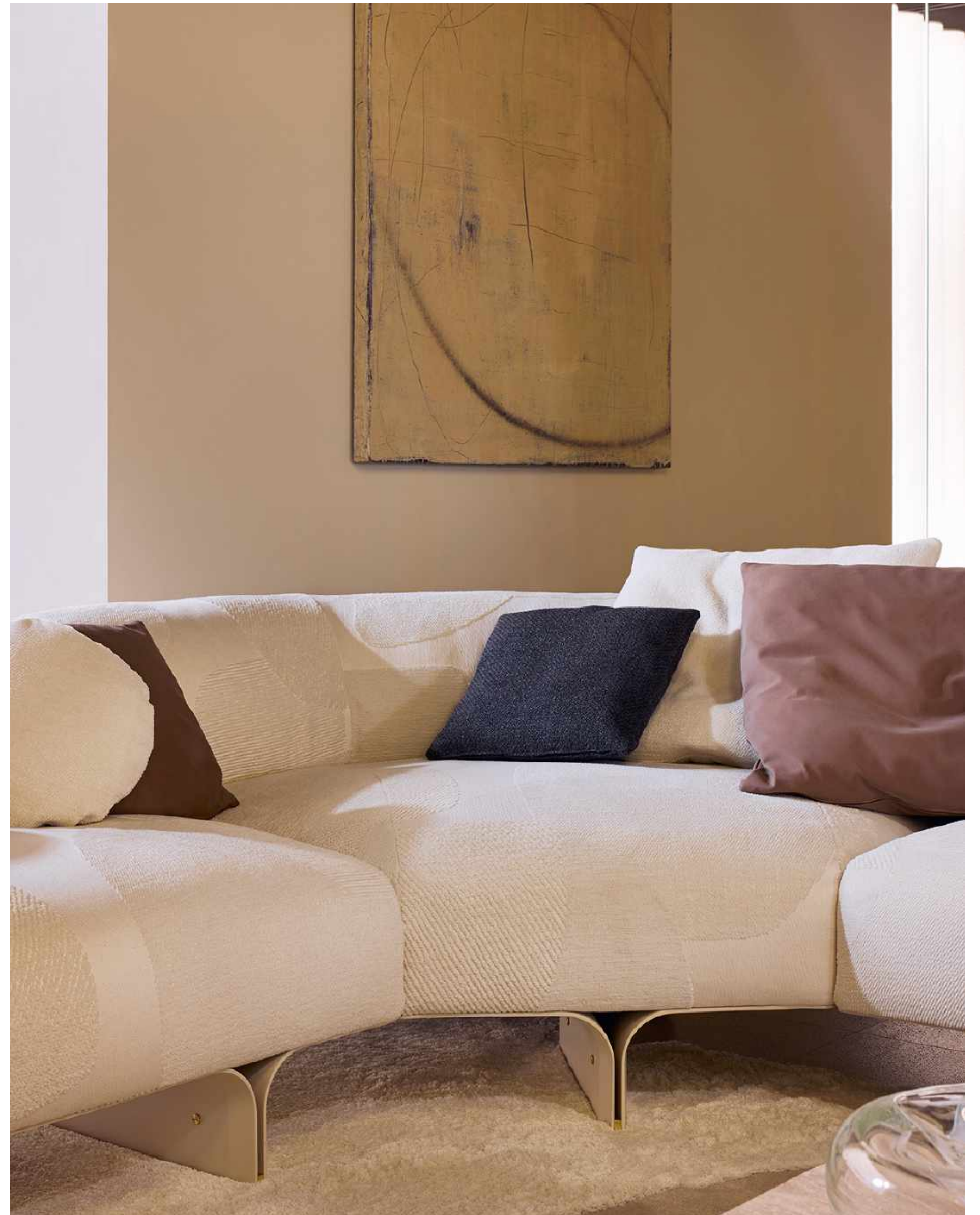

LIVING 1



# Stami Sofa

DESIGN STUDIOPEPE



STAMI SOFA | STUDIOPEPE

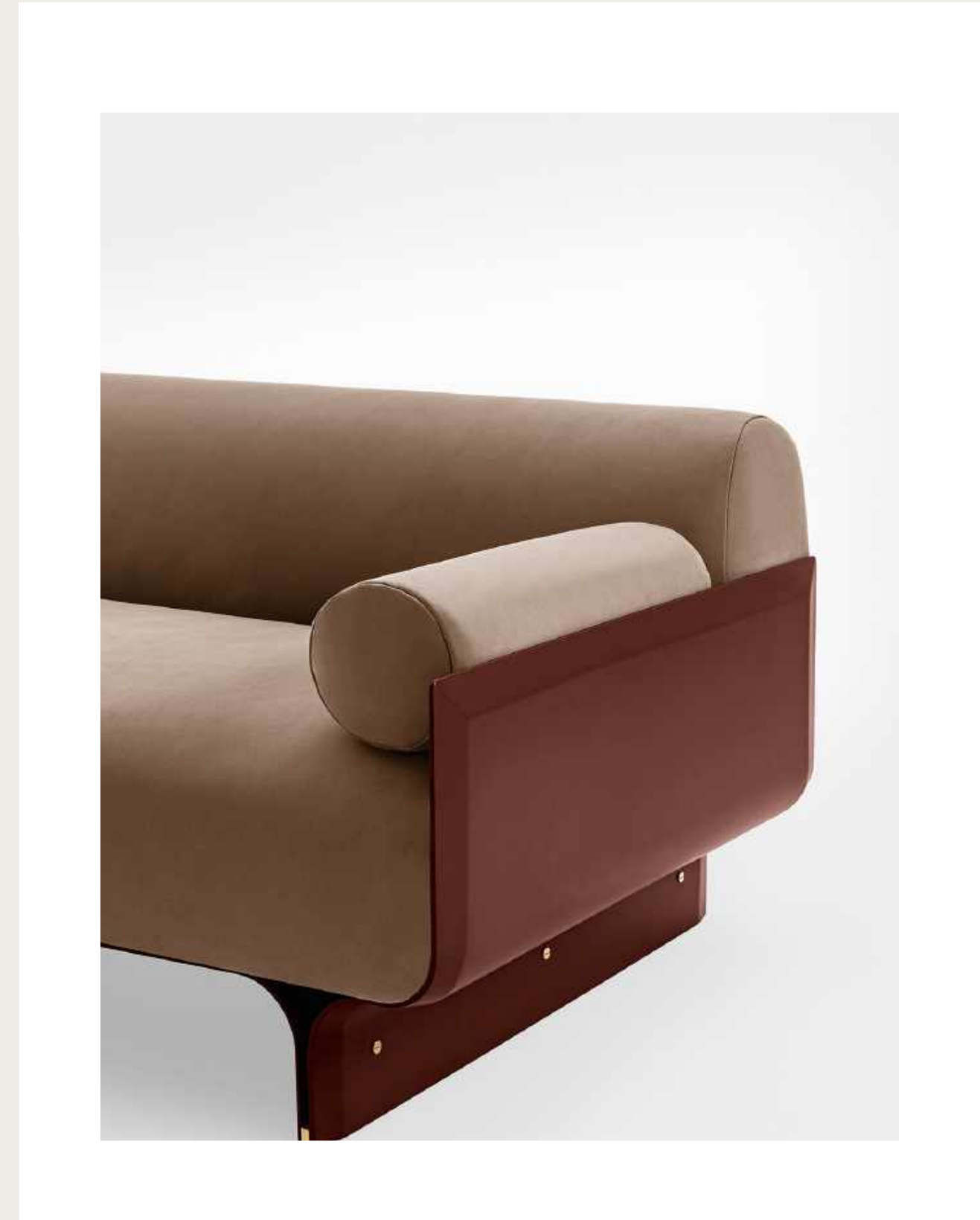

# Stami Sofa

## DESIGN STUDIOPEPE

Sofa with curved black open pore stained ash base and bright brass details. Also available opaque lacquered wooden version in the colours "Rosso Persia", "Grigio Londra", "Nero Giza", "Bianco Camargue", "Verde Provenza", "Blu Pacifico", "Bordeaux Etruria", "Rosa Jaipur" and "Sabbia del Nilo".  
 Padding in polyurethane foam and goose down covered by fabric or leather as per samples.  
 Supplied with two goose down padding cylindrical armrests covered in the same fabric/leather as the sofa.  
 Removable cover.

Additional stitching is required for elements with leather upholstery compared to elements with fabric upholstery.

### DIMENSIOIS

Cm	Inches
220 x 90 x 70h	86¾" x 35½" x 27¾"h
250 x 90 x 70h	98½" x 35½" x 27¾"h
280 x 90 x 70h	110¼" x 35½" x 27¾"h

### STRUCTURE FINISH

<i>OPEN PORE STAINED</i>	<i>OPAQUE LACQUERED</i>	<i>OPAQUE LACQUERED</i>	<i>OPAQUE LACQUERED</i>	<i>OPAQUE LACQUERED</i>
				
BLACK OPEN PORE	ROSSO PERSIA	GRIGIO LONDRA	NERO GIZA	BIANCO CAMARGUE
<i>OPAQUE LACQUERED</i>	<i>OPAQUE LACQUERED</i>	<i>OPAQUE LACQUERED</i>	<i>OPAQUE LACQUERED</i>	<i>OPAQUE LACQUERED</i>
				
VERDE PROVENZA	BLU PACIFICO	BORDEAUX ETRURIA	ROSA JAIPUR	SABBIA DEL NILO

## STAMI SOFA | STUDIOPEPE

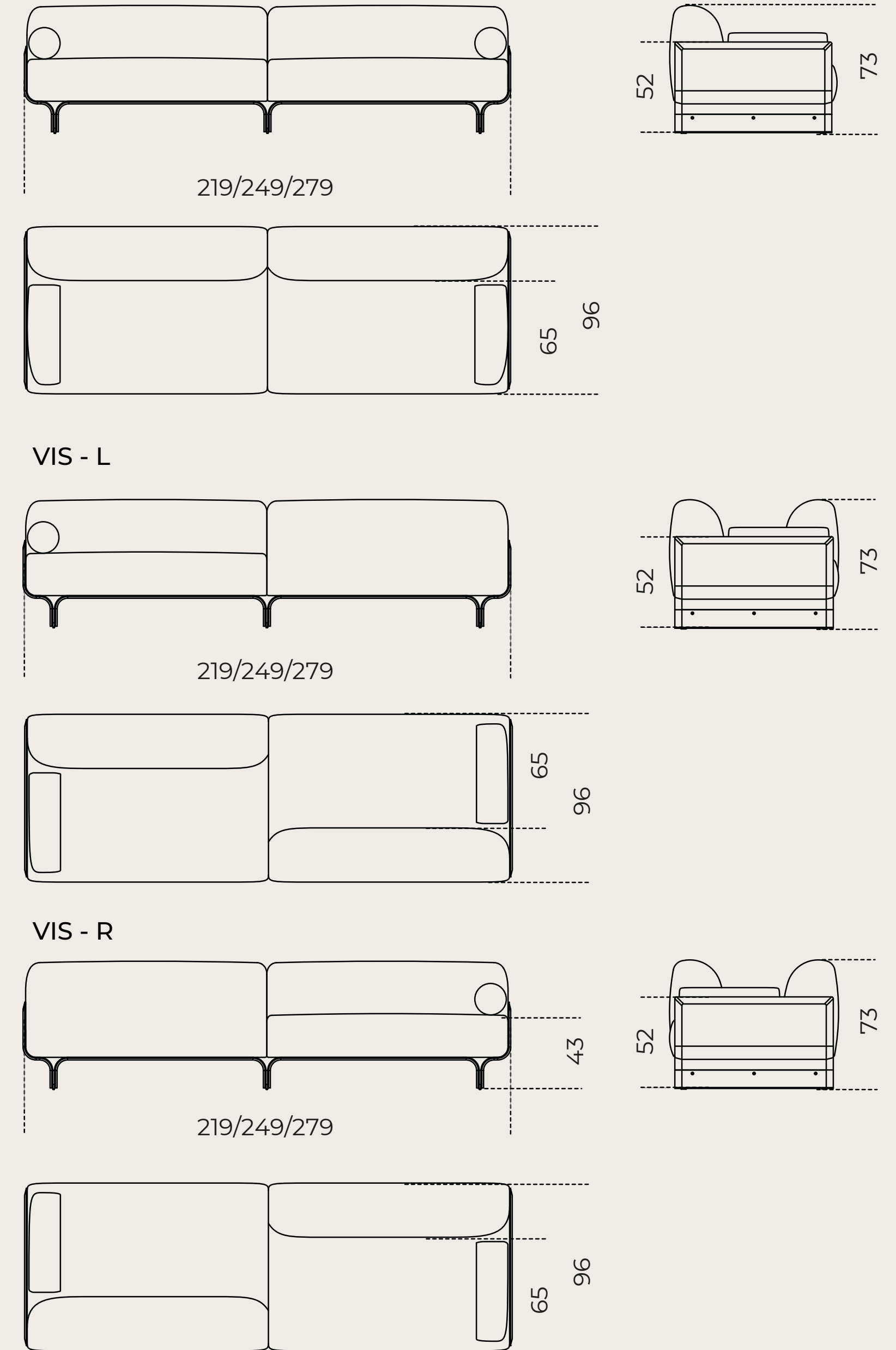



*STAMI SOFA*

# Stami Sofa Plus

DESIGN STUDIOPEPE



STAMI SOFA PLUS | STUDIOPEPE



# Stami Sofa Plus

## DESIGN STUDIOPEPE

Modular sofa with curved black open pore stained ash base and bright brass details. Also available opaque lacquered wooden version in the colours "Rosso Persia", "Grigio Londra", "Nero Giza", "Bianco Camargue", "Verde Provenza", "Blu Pacifico", "Bordeaux Etruria", "Rosa Jaipur" and "Sabbia del Nilo".

Padding in polyurethane foam and goose down covered by fabric or leather as per samples.

Final module supplied with one goose down padding cylindrical armrest covered in the same fabric/leather as the sofa.

Removable cover.

Additional stitching is required for elements with leather upholstery compared to elements with fabric upholstery.

## DIMENSIONS

Cm	Inches
110 x 90 x 70h	43½" x 35½" x 27¾"h
125 x 90 x 70h	49¼" x 35½" x 27¾"h
140 x 90 x 70h	55¼" x 35½" x 27¾"h
225 x 147 x 69h	88¾" x 58" x 27¼"h

## STRUCTURE FINISH

OPEN PORE STAINED	OPAQUE LACQUERED	OPAQUE LACQUERED	OPAQUE LACQUERED	OPAQUE LACQUERED
				
BLACK OPEN PORE	ROSSO PERSIA	GRIGIO LONDRA	NERO GIZA	BIANCO CAMARGUE
OPAQUE LACQUERED	OPAQUE LACQUERED	OPAQUE LACQUERED	OPAQUE LACQUERED	OPAQUE LACQUERED
				
VERDE PROVENZA	BLU PACIFICO	BORDEAUX ETRURIA	ROSA JAIPUR	SABBIA DEL NILO

## STAMI SOFA PLUS | STUDIOPEPE

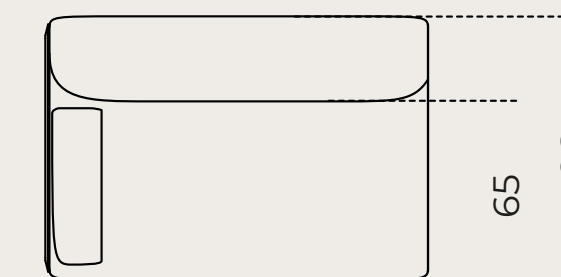
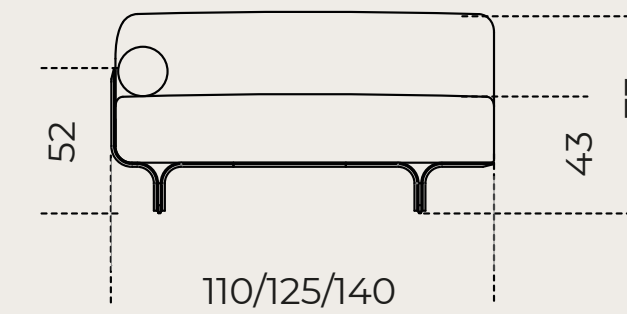

END MODULES

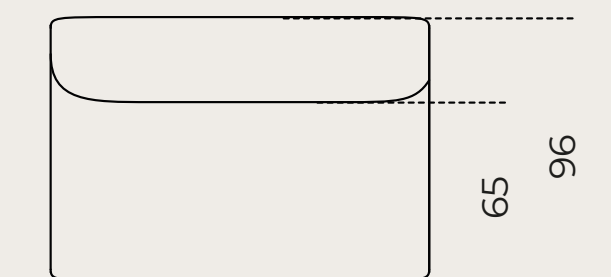
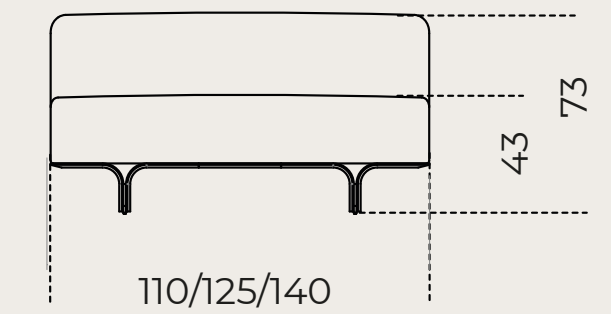
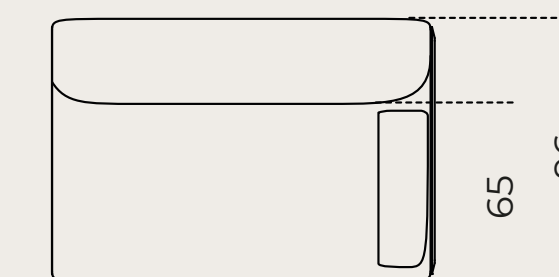
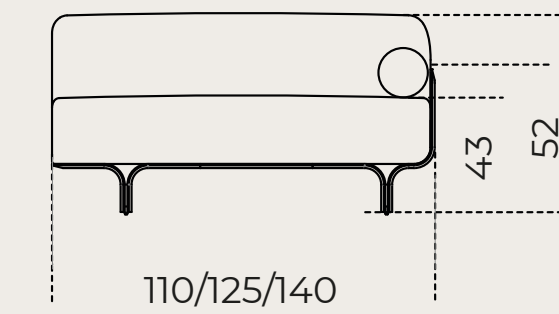

CENTRAL MODULE

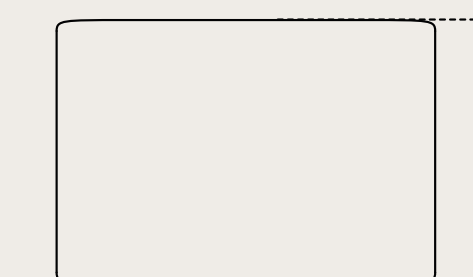
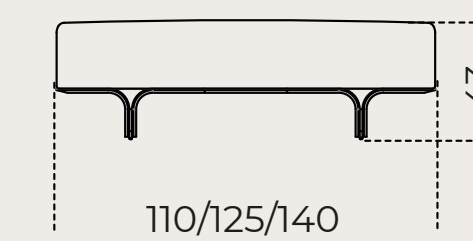

POUF

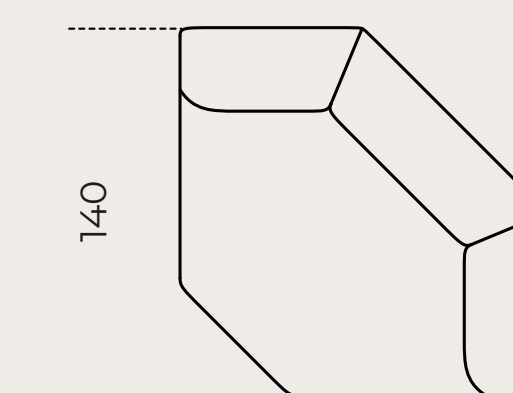
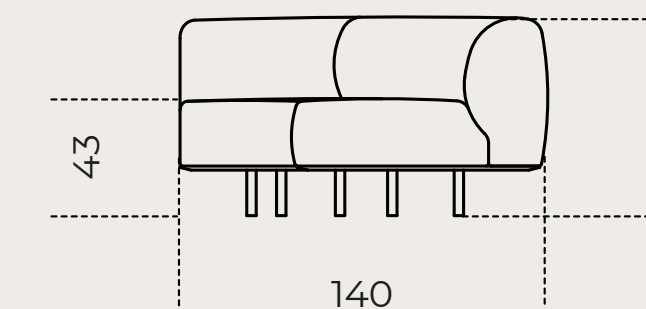

ANGULAR MODULE



*STAMI SOFA PLUS*

STAMI SOFA | COMPOSITIONS

COMPOSITION 1

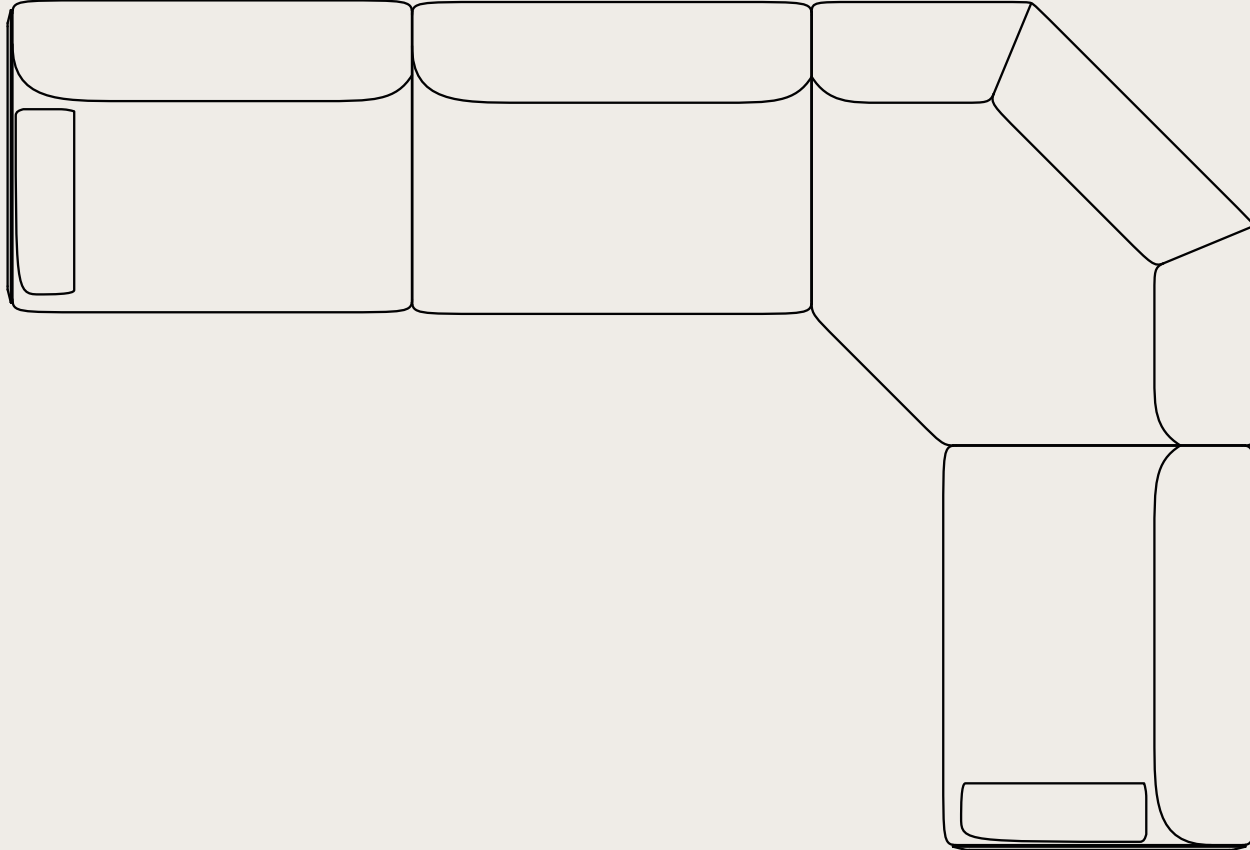

COMPOSITION 2

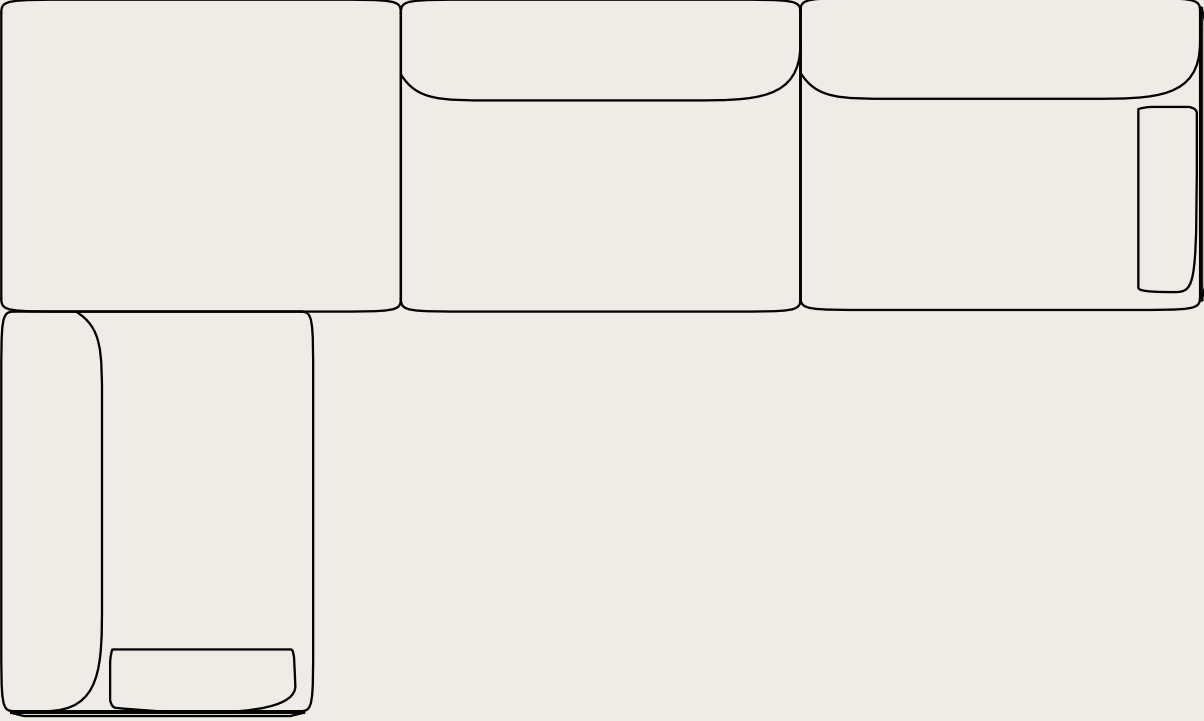

COMPOSITION 3

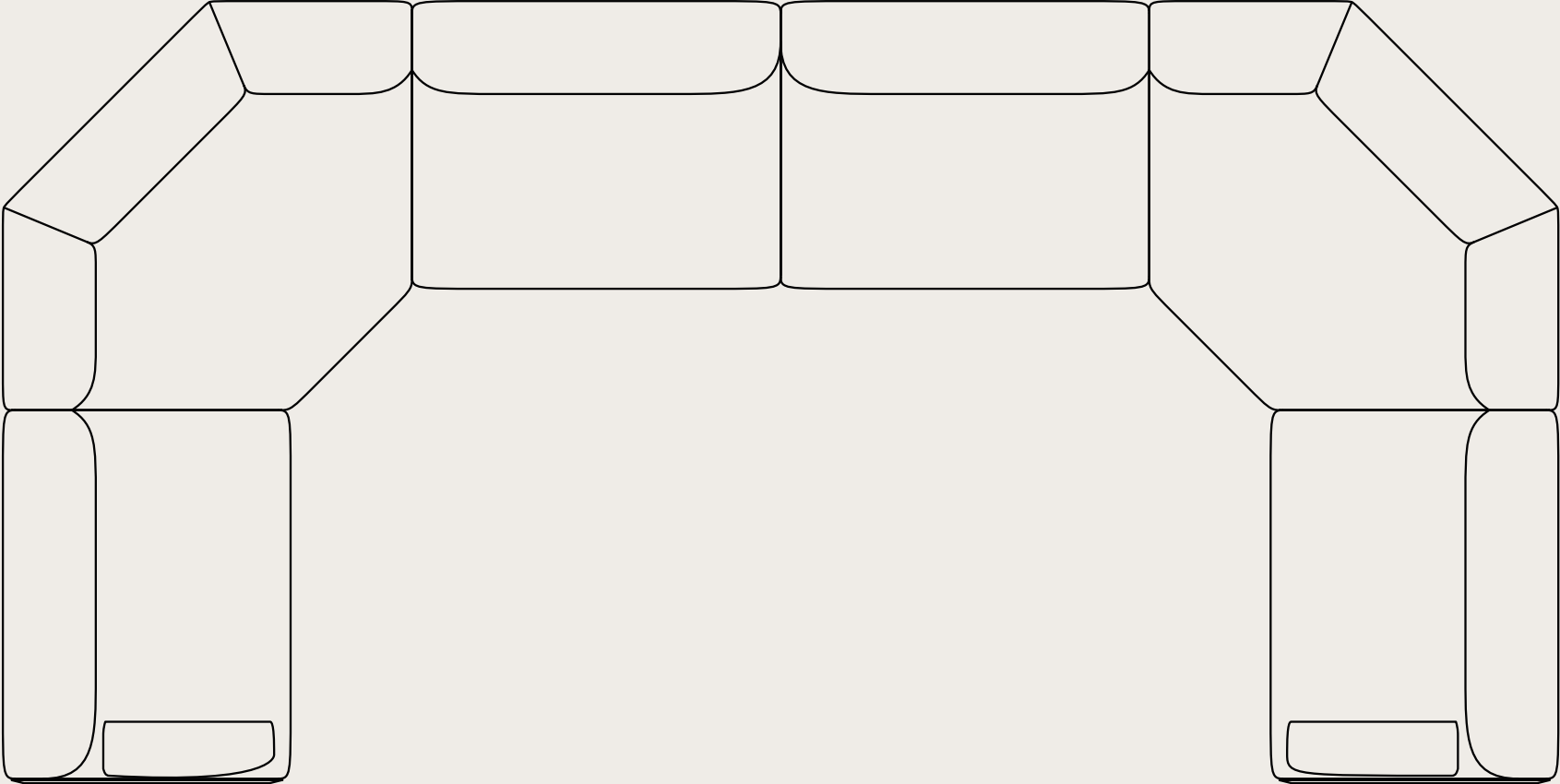

# Chantal

DESIGN STUDIO G&R



CHANTAL | STUDIO G&R





# Chantal

DESIGN STUDIO G&R

Coffee table with top and structure in black hand brushed anodized in the colour black.

Also available version in hand brushed aluminium opaque lacquered in the colours "Rosso Persia", "Grigio Londra", "Nero Giza", "Bianco Camargue", "Verde Provenza", "Blu Pacifico", "Bordeaux Etruria", "Rosa Jaipur" and "Sabbia del Nilo".

## DIMENSIOIS

Cm	Inches
A 40 x 40 x 50h	15¾" x 15¾" x 19¾"h
B 60 x 60 x 45h	23¾" x 23¾" x 17¾"h
C 60 x 60 x 30h	23¾" x 23¾" x 12"h
D 60 x 60 x 25h	23¾" x 23¾" x 10"h

## FINISHES

	<i>OPAQUE LACQUERED</i> 	<i>OPAQUE LACQUERED</i> 	<i>OPAQUE LACQUERED</i> 	<i>OPAQUE LACQUERED</i> 
BLACK ANODISED	ROSSO PERSIA	GRIGIO LONDRA	NERO GIZA	BIANCO CAMARGUE
<i>OPAQUE LACQUERED</i> 	<i>OPAQUE LACQUERED</i> 	<i>OPAQUE LACQUERED</i> 	<i>OPAQUE LACQUERED</i> 	<i>OPAQUE LACQUERED</i> 
VERDE PROVENZA	BLU PACIFICO	BORDEAUX ETRURIA	ROSA JAIPUR	SABBIA DEL NILO

CHANTAL | STUDIO G&R

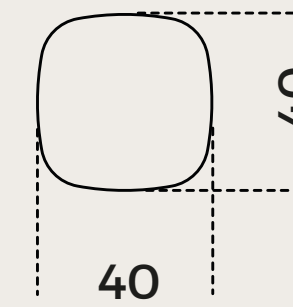
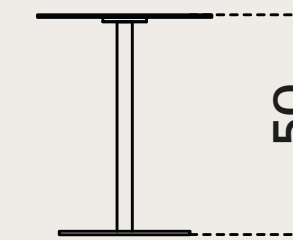

**A**

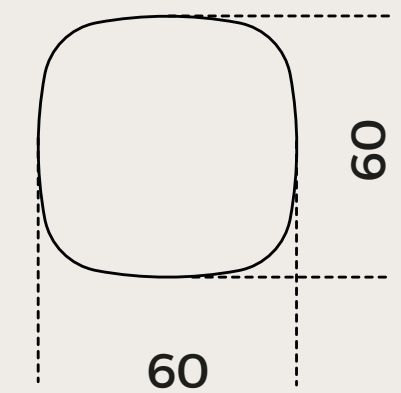
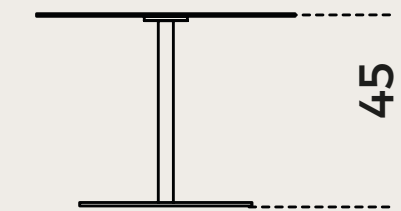

**B**

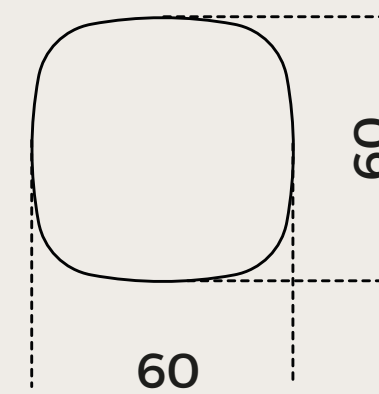
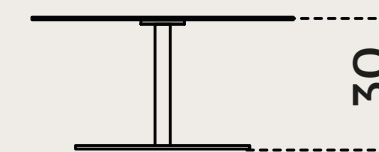

**C**

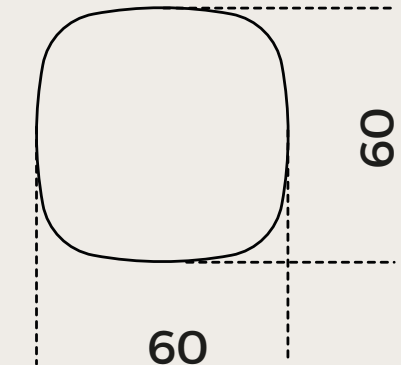
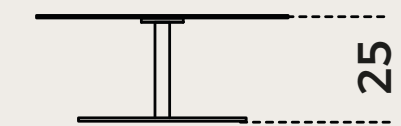

**D**

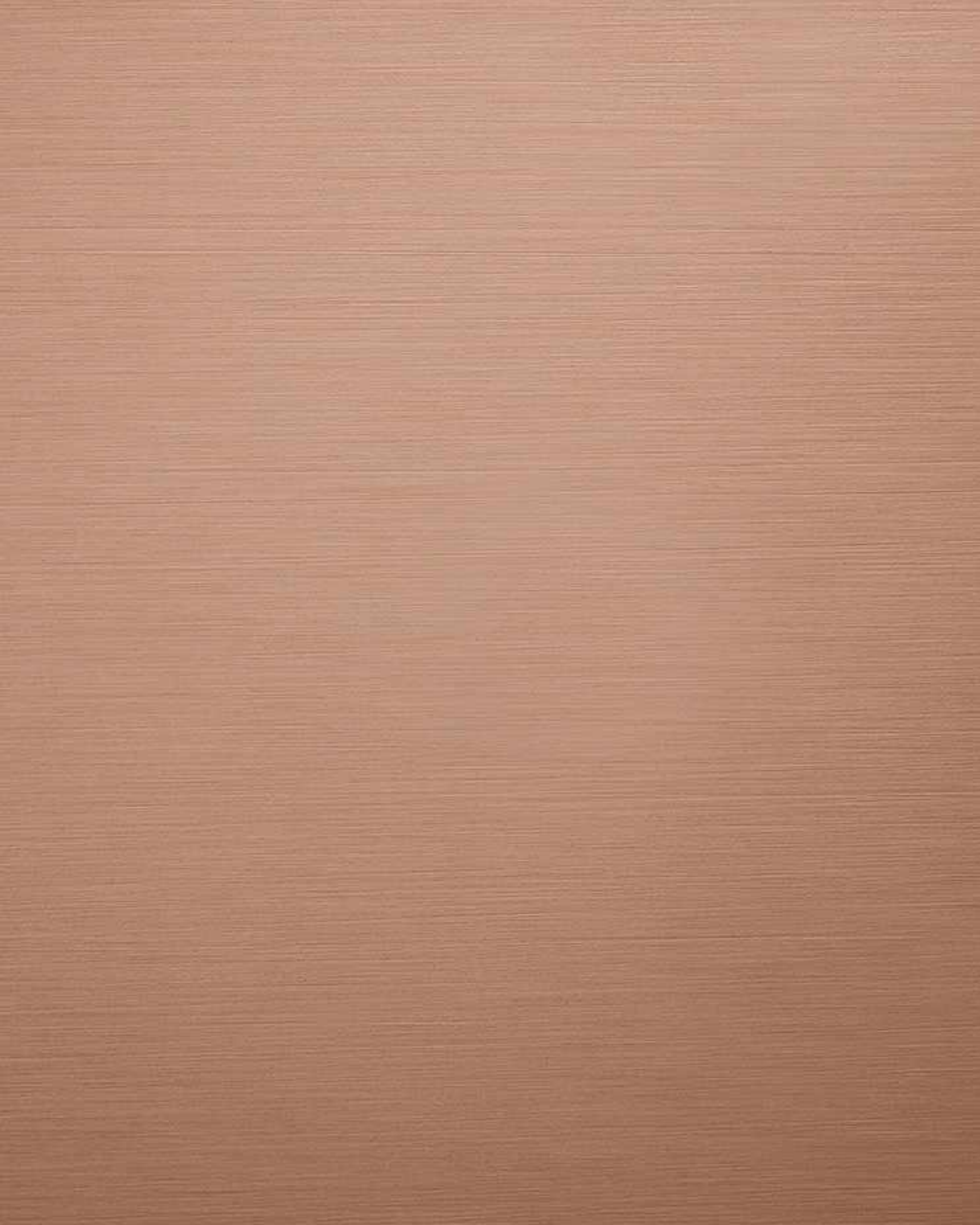

*CHANTAL*

2024 COLLECTION

# DINING 1

SALONE DEL  
MOBILE.MILANO  
2024





DINING 1

# Molecola

DESIGN MASSIMO CASTAGNA



MOLECOLA | MASSIMO CASTAGNA



# Molecola

DESIGN MASSIMO CASTAGNA

Table with 15mm transparent tempered glass top. Hand-brushed wooden cylinders base. Available in brick, rope, charcoal or ivory colours.

## DIMENSIONS

Cm	Inches
○ $\varnothing 180 \times 74,5$ $\varnothing 200 \times 74,5h$	$\varnothing 71" \times 29\frac{1}{2}"h$ $\varnothing 78\frac{3}{4}" \times 29\frac{1}{2}"h$
○ $240 \times 150 \times 74,5$ $260 \times 150 \times 74,5$	$94\frac{1}{2}" \times 59\frac{1}{4}" \times 29\frac{1}{2}"h$ $102\frac{1}{4}" \times 59\frac{1}{4}" \times 29\frac{1}{2}"h$
$300 \times 150 \times 74,5$ $320 \times 150 \times 74,5$	$118\frac{1}{4}" \times 59\frac{1}{4}" \times 29\frac{1}{2}"h$ $126" \times 59\frac{1}{4}" \times 29\frac{1}{2}"h$

## FINISHES

HAND SPATULATED



BRICK

HAND SPATULATED



ROPE

HAND SPATULATED



IVORY

HAND SPATULATED



CHARCHOAL

MOLECOLA | MASSIMO CASTAGNA

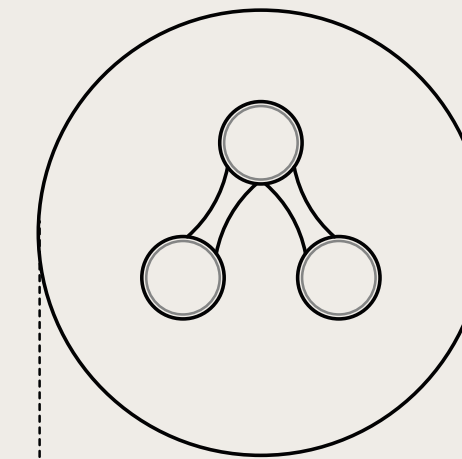
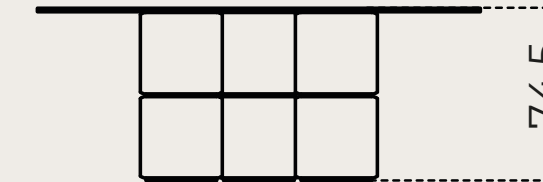

$\varnothing 180/200$

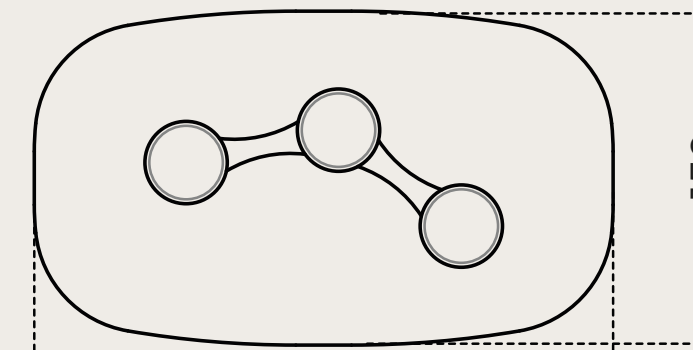
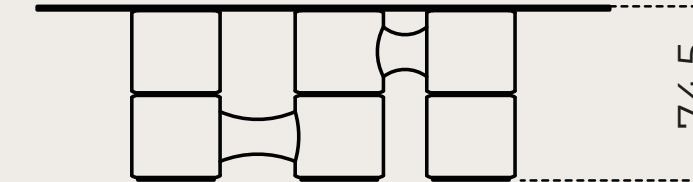

240/260

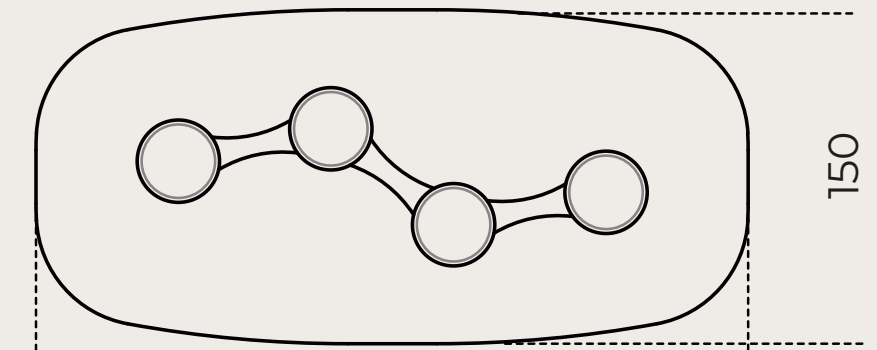
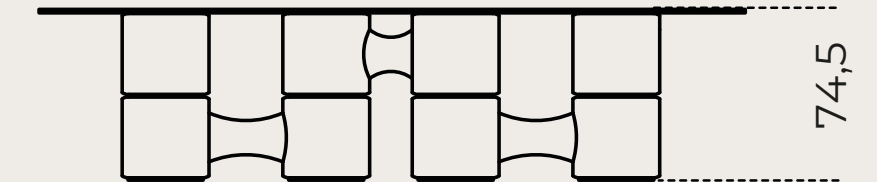

300/320

*Coating made with mixture  
of cement and other materials.*

**Brick Color**

*Composed of red powdered earthenware.*

**Rope Color**

*composed of quartz powder*

**Charcoal color**

*Composed of powdered ebony stone.*

*Finished with water-based acrylic clear coat.*

**BRICK**

SELCE-T | STUDIOPEPE



**WHITE**



**ROPE**

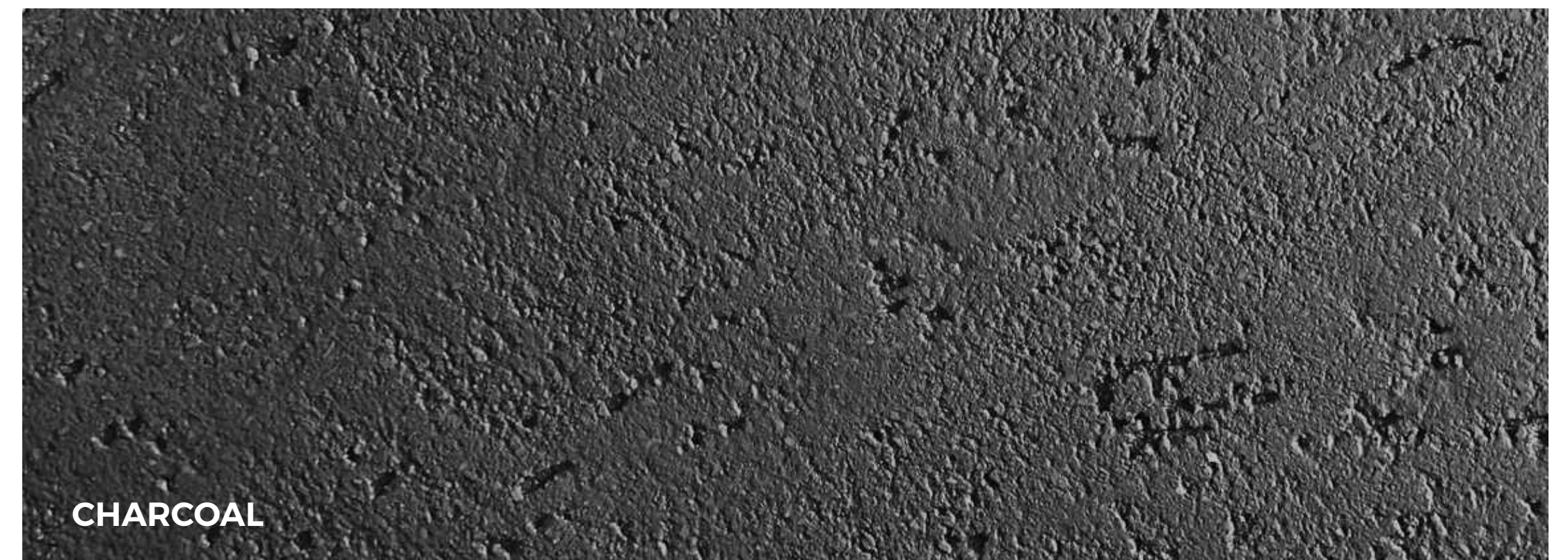

**CHARCOAL**

# Sensei bench

DESIGN TOLLGARD + CASTELLANI



SENSEI BENCH | TOLLGARD + CASTELLANI





# Sensei bench

DESIGN TOLLGARD + CASTELLANI

Bench with "deep black" lacquered metal structure and wooden top. On the wooden top, 6cm non-deformable foam polyurethane cushion covered by fabric or leather as per samples.  
Not removable cover.

For the 180cm bench available version with cushion and 12mm glass top with half bull-nose grinding in the exclusive finish "Rosso Marte" or painted as per samples in the bright version. Also available with 20mm brushed Ceppo di Gré®, satin Arabescato Orobico Rosso marble, brushed Bianco Carrara Gioia marble or satin Dover White marble.

## DIMENSIONS

Cm	Inches
137 x 45 x 39,5h	54" x 17¾" x 15¾"h
180 x 45 x 39,5h	71" x 17¾" x 15¾"h

SENSEI BENCH | TOLLGARD + CASTELLANI

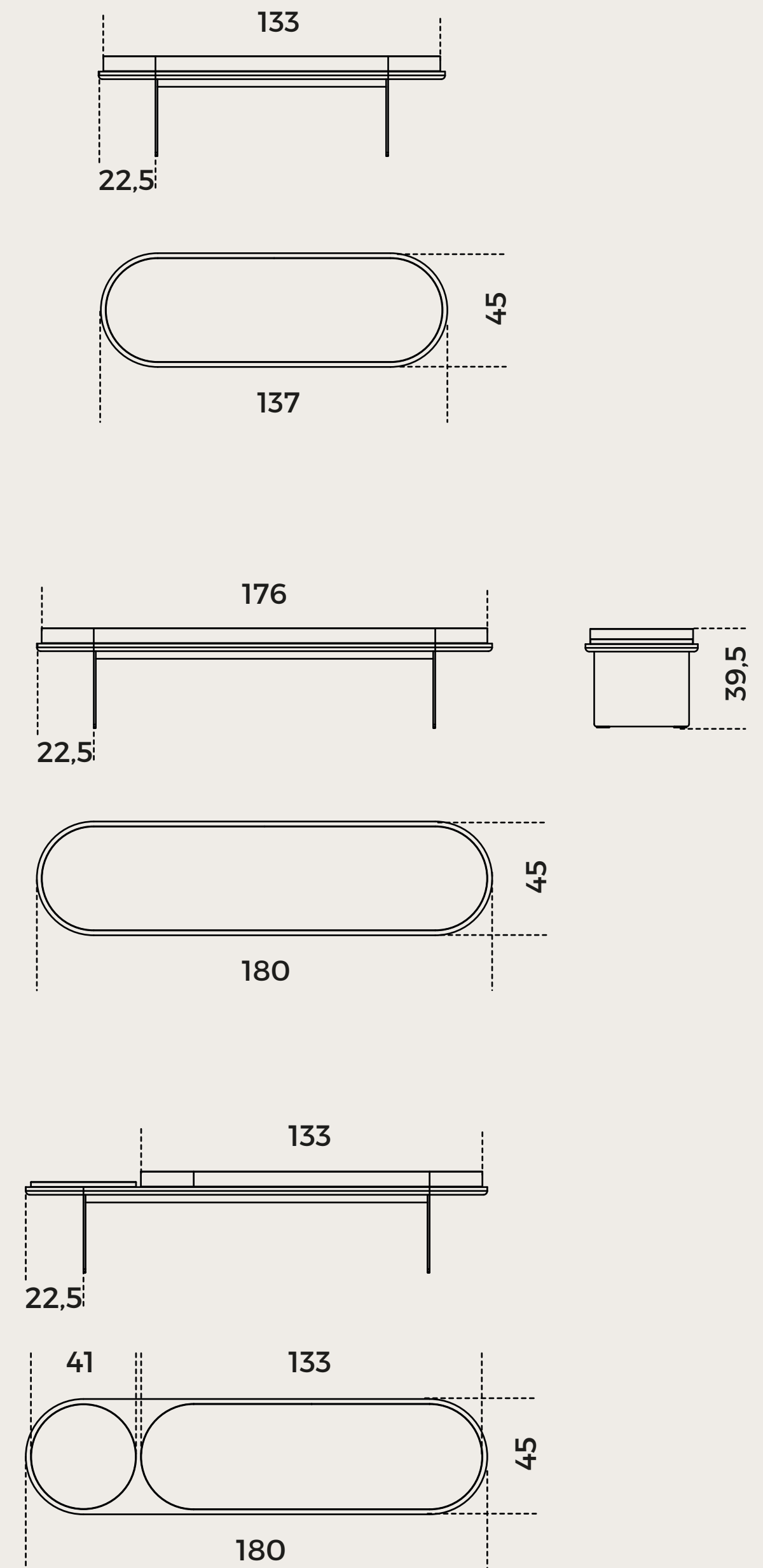

**GLASS TOP:**

EXCLUSIVE ARTISANAL FINISH  
'ROSSO MARTE'

BACKPAINTED GLOSSY GLASS IN ALL  
THE COLOURS OF THE COLLECTION



**MARBLE TOP:**

BRUSHED CEPPPO DI GRÉ

ARABESCATO OROBICO ROSSO

BRUSHED BIANCO CARRARA GIOIA

DOVER WHITE

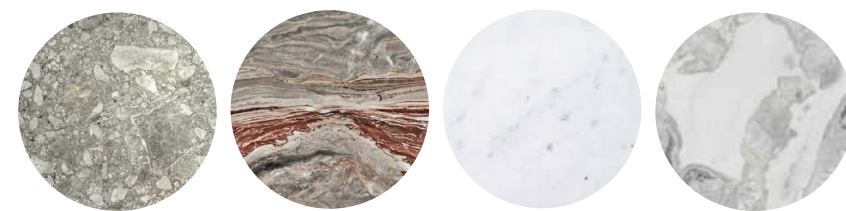

**STRUCTURE:**

METAL AND WOOD  
LACQUERED IN THE  
'DEEP BLACK'  
COLOUR

**SEAT:**

FABRIC OR LEATHER  
FROM THE COLLECTION

SENSEI BENCH | TOLLGARD + CASTELLANI



# Stami Sideboard

DESIGN STUDIOPEPE



STAMI SIDEBOARD | STUDIOPEPE



# Stami Sideboard

DESIGN STUDIOPEPE

Sideboard with curved black open pore stained ash base and bright brass details.  
Wooden unit covered by leather fard as per samples. Supplied with 10mm extralight inside glass shelf.

## DIMENSIONS

Cm	Inches
179 x 50 x 74,4h	70½" x 19¾" x 29½"h
233 x 50 x 74,4h	91¾" x 19¾" x 29½"h

## FINISHES OF THE STRUCTURE

OPEN PORE



STAINED ASH BLACK

## FINISHES OF THE STRUCTURE

FARD

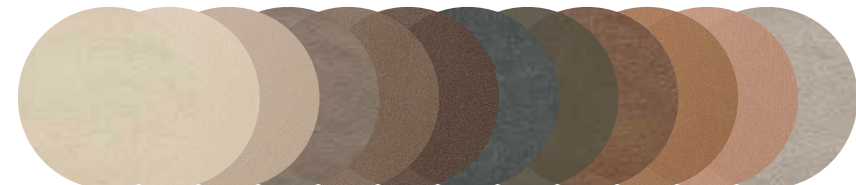

ALL COLORS

STAMI SIDEBOARD | STUDIOPEPE

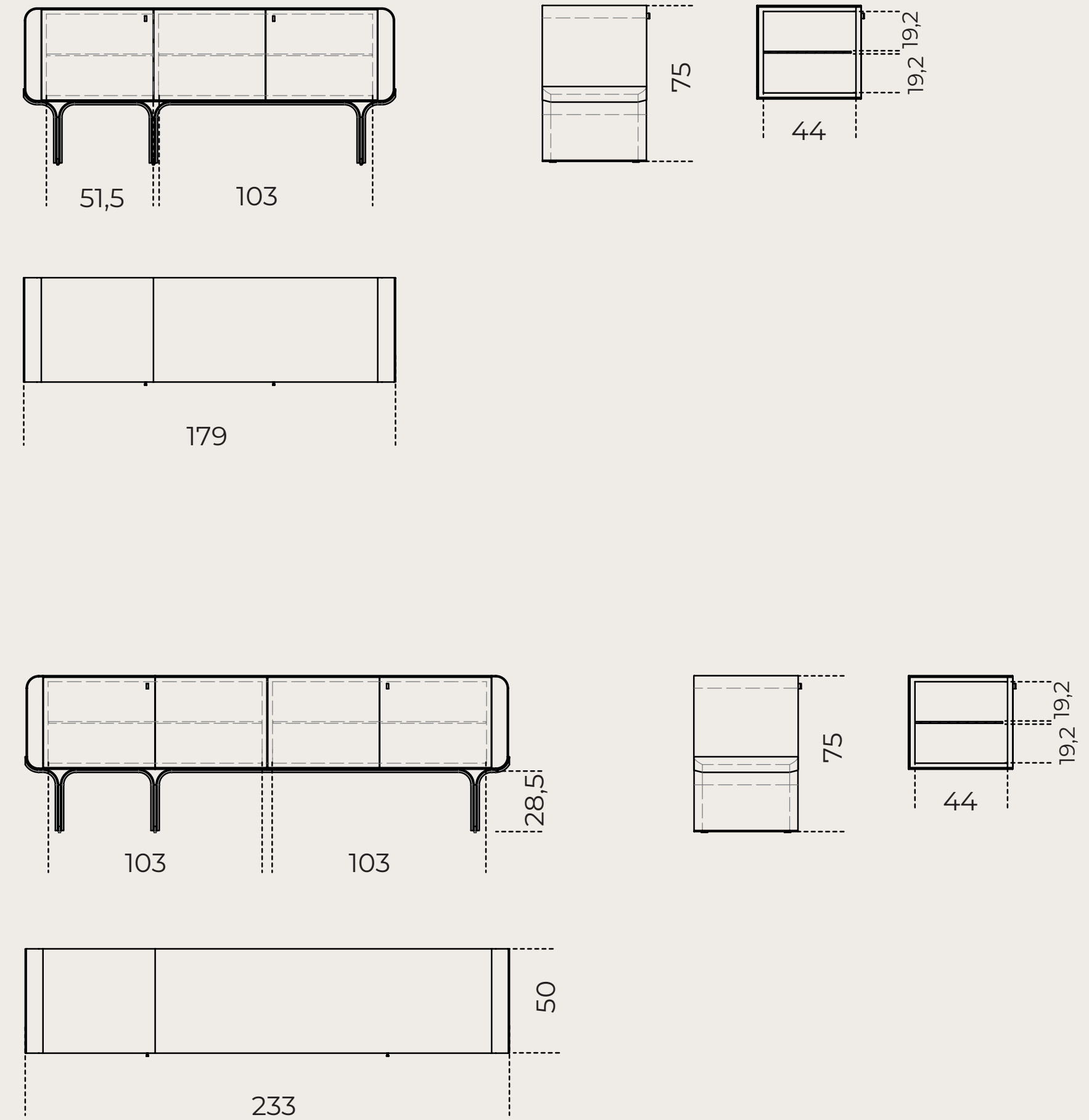

2024 COLLECTION

# LIVING 2

SALONE DEL  
MOBILE.MILANO  
2024





LIVING 2

# Cloud Infinity

DESIGN MASSIMO CASTAGNA



CLOUD INFINITY | MASSIMO CASTAGNA



# Cloud Infinity

DESIGN MASSIMO CASTAGNA

Modular sofa in non-deformable foam polyurethane in different density and polyester fibre with wooden inside structure. Black lacquered wooden feet. Available covered by fabric or leather as per samples. Not removable cover. Fango lacquered wooden side table on request. Also available with natural brushed Travertino Romano (not treated with resin), natural polish Calacatta Vagli Oro or brushed Emperador Brown marble top. Modules cannot be sold individually. On demand removable covers excluding Cat. L1, L2 and customer leather C.O.L.

## DIMENSIONS

Cm	Inches
T1 76 x 110 x 75h	T1 30" x 39½" x 29¾"h
T2 114 x 110 x 75h	T2 45" x 39½" x 29¾"h
T3 152 x 110 x 75h	T3 60" x 39½" x 29¾"h
TA 170 x 124 x 75h	TA 67" x 49" x 29¾"h
CA 140 x 124 x 75h	CA 55¼" x 49" x 29¾"h
C2 76 x 110 x 75h	C2 30" x 39½" x 29¾"h
C3 114 x 110 x 75h	C3 45" x 39½" x 29¾"h
TCL 152 x 165 x 75h	TCL 60" x 65" x 29¾"h
<b>CA-90 150 x 150 x 75h</b>	<b>CA-90 59¼" x 59¼" x 29¾"h</b>
Side table 100 x 40 x 35h	Side table 39½" x 15¾" x 14"h
Decorative cushion	Decorative Cushion
40 x 40	15¾" x 15¾"
60 x 60	23¾" x 23¾"

CLOUD INFINITY | MASSIMO CASTAGNA

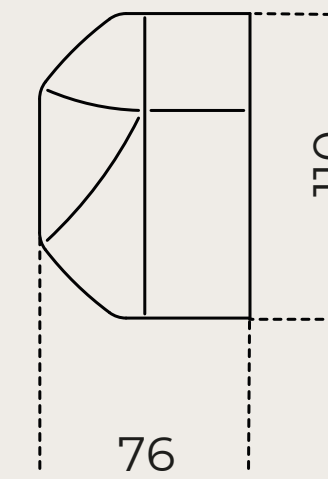
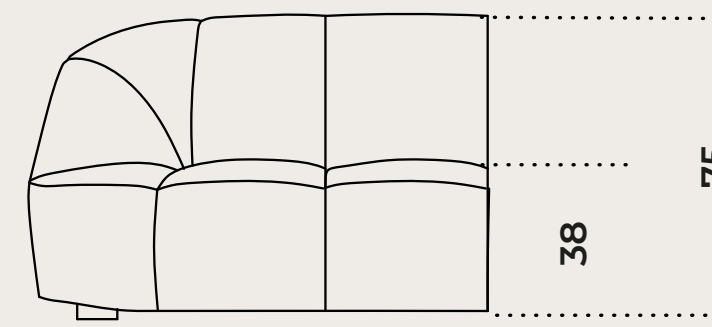

T1

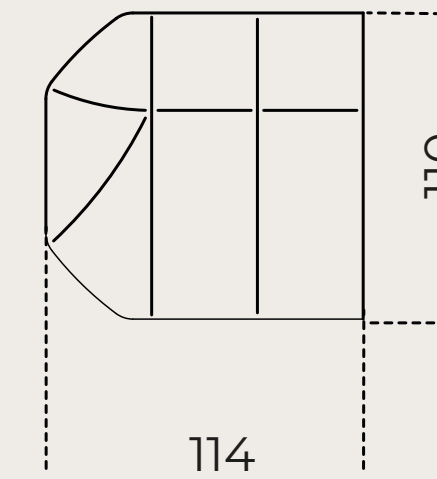

T2

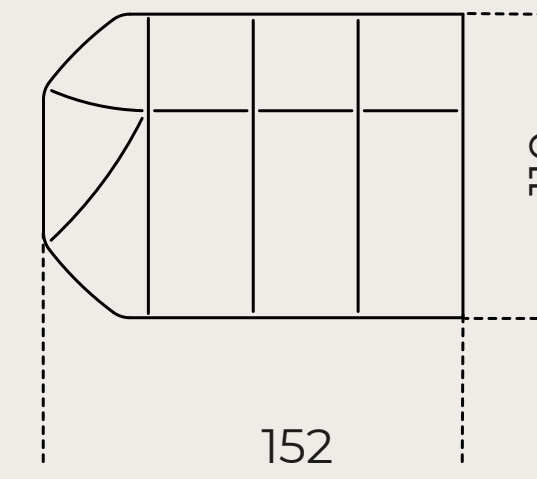

T3

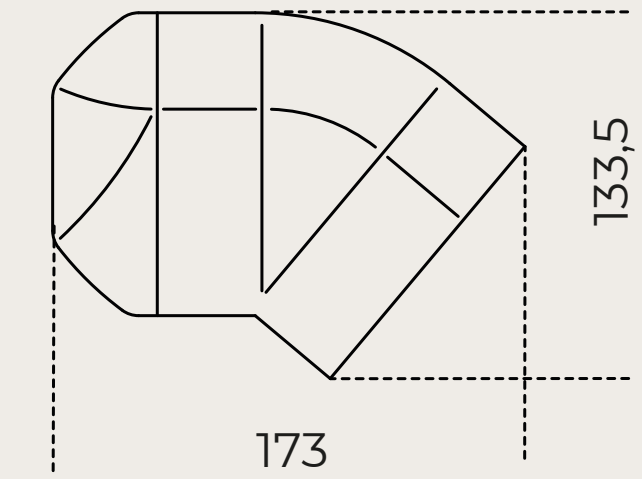

TA

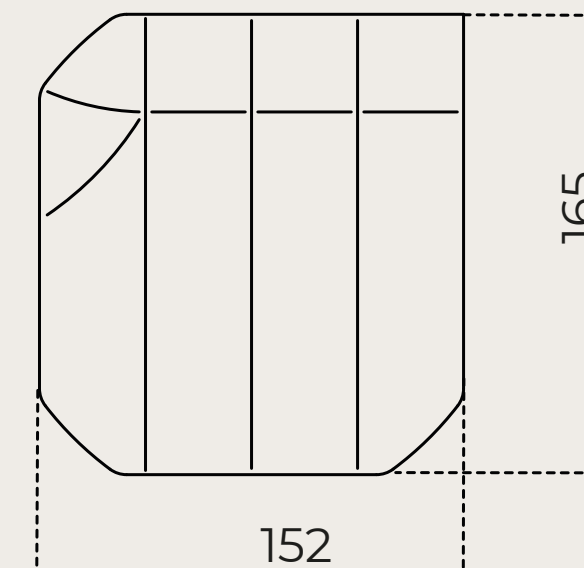

TCL

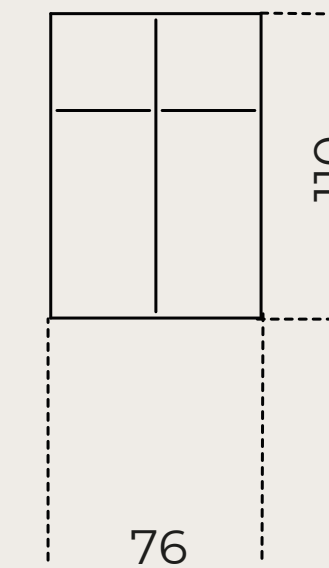

C2

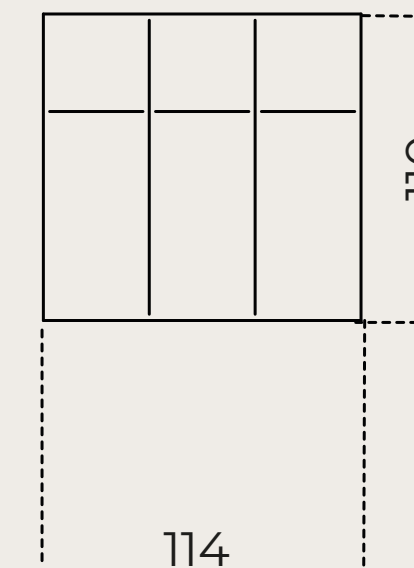

C3

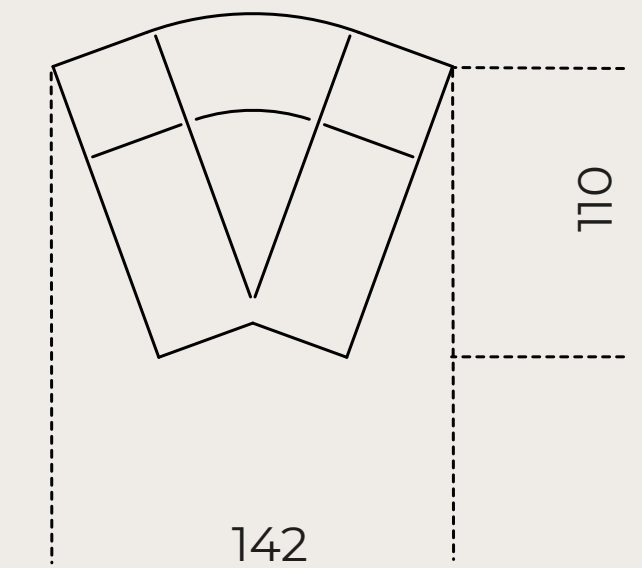

CA

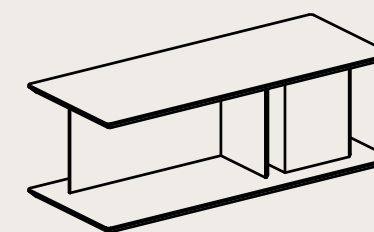

Side table with lacquered top

100 x 40 x 35h

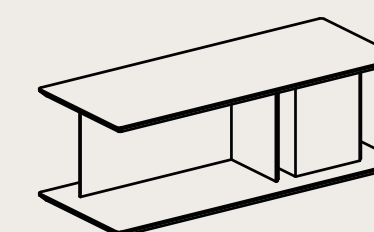

Side table with marble top  
[Travertino Romano,  
Calacatta Vagli Oro,  
Emperador Brown]

100 x 40 x 35h

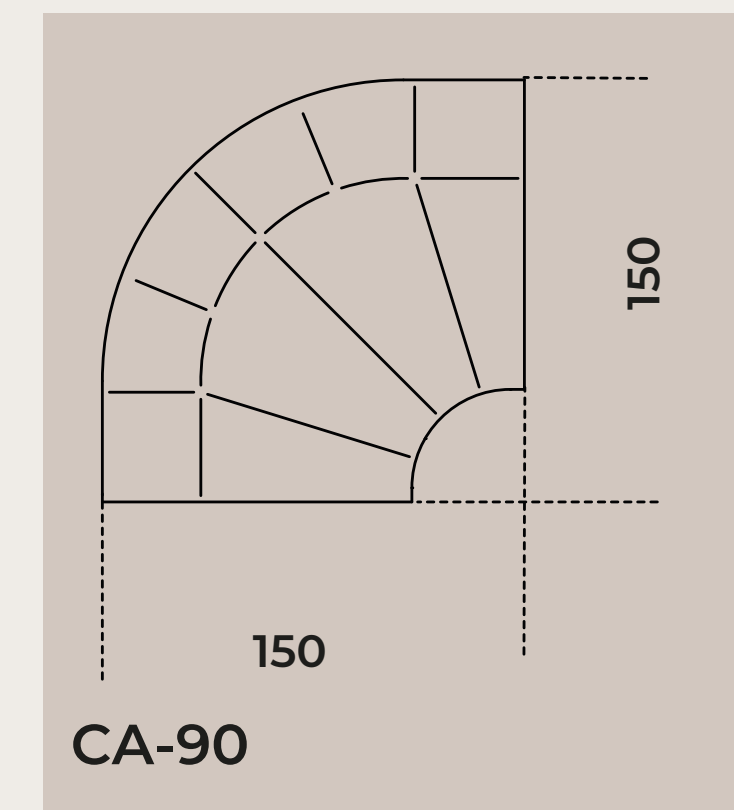

CA-90



CLOUD INFINITY | COMPOSITIONS

COMPOSITION 1

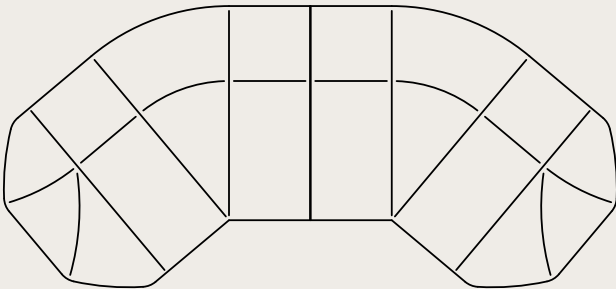

COMPOSITION 2

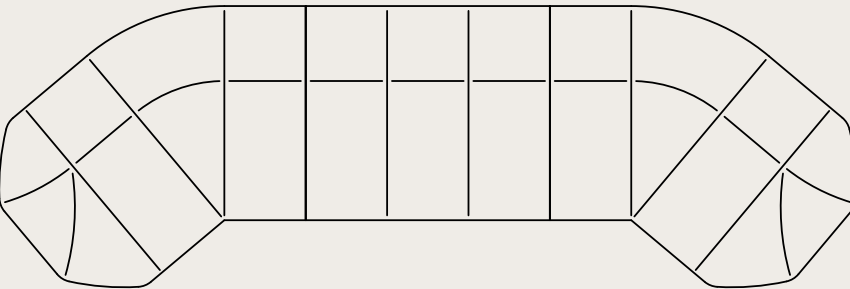

COMPOSITION 3

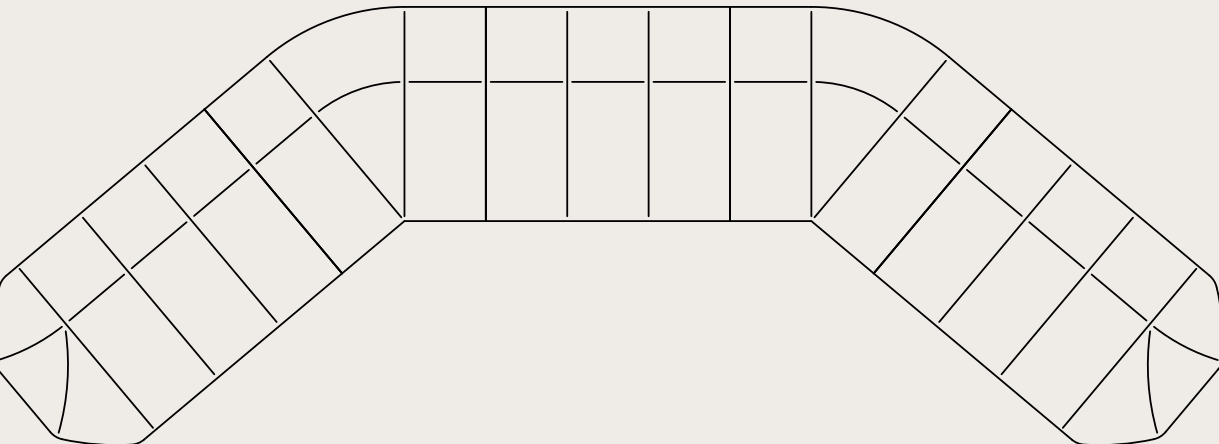

COMPOSIZIONE 4

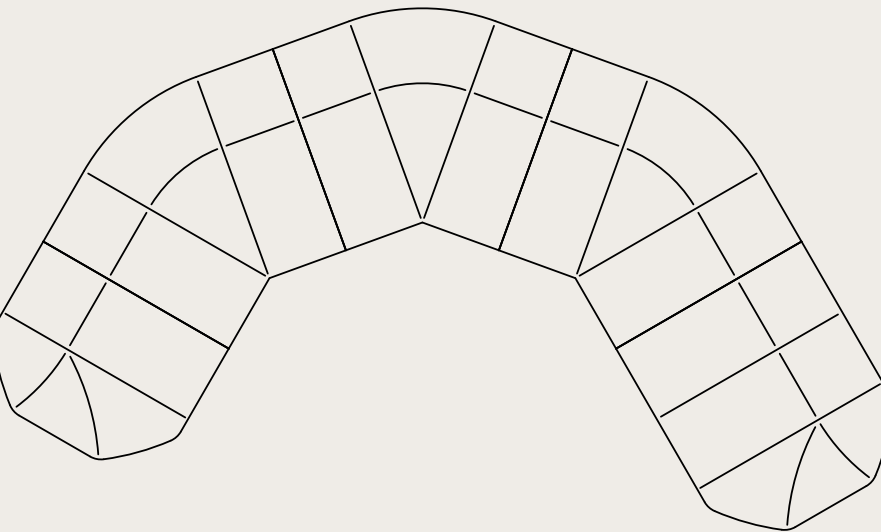

COMPOSITION 5

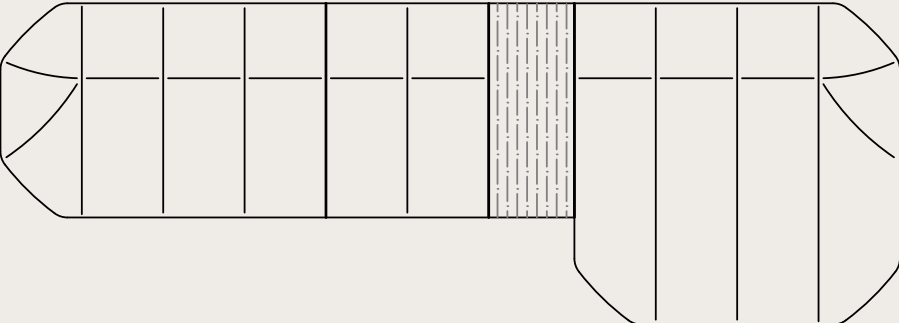

COMPOSITION 6

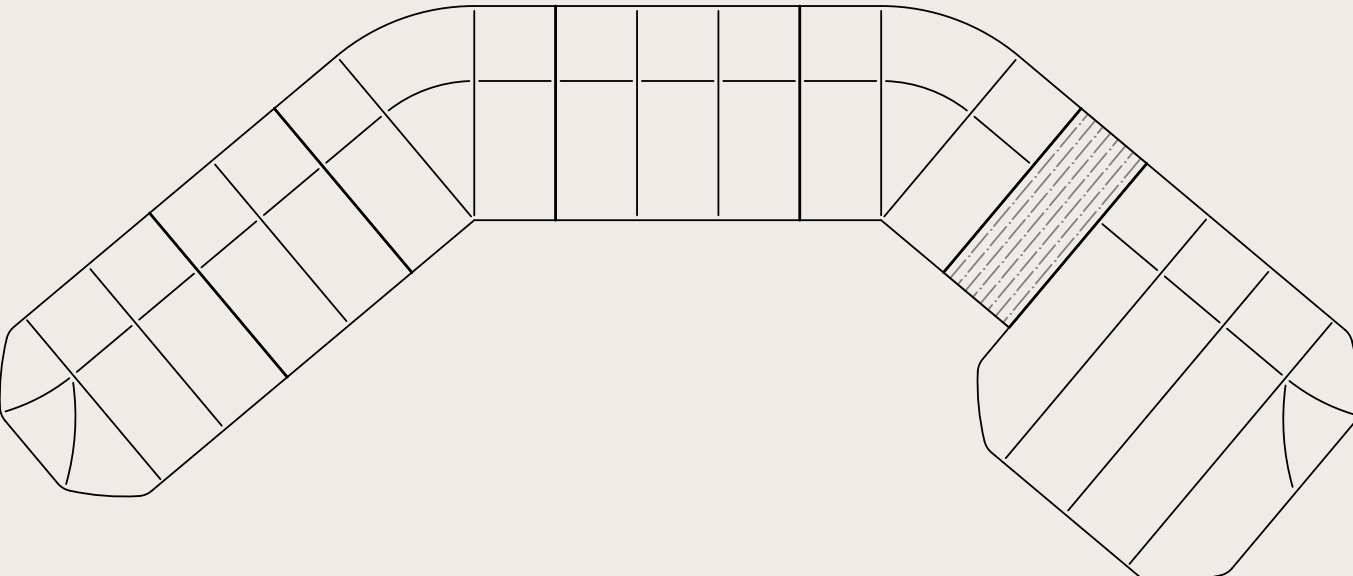

COMPOSITION 7

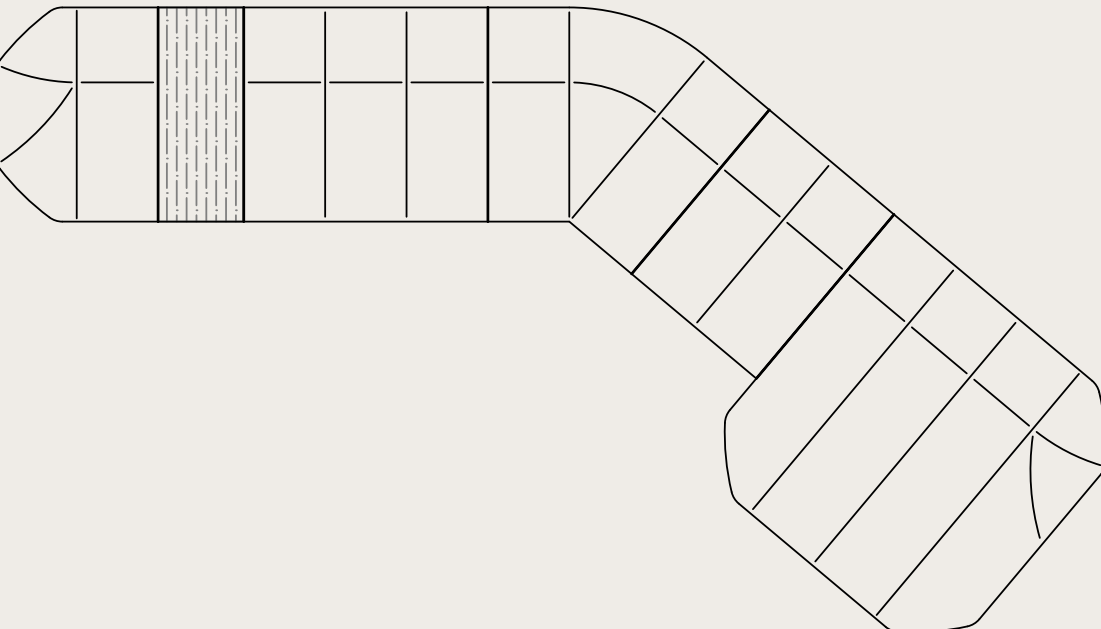

COMPOSITION 8

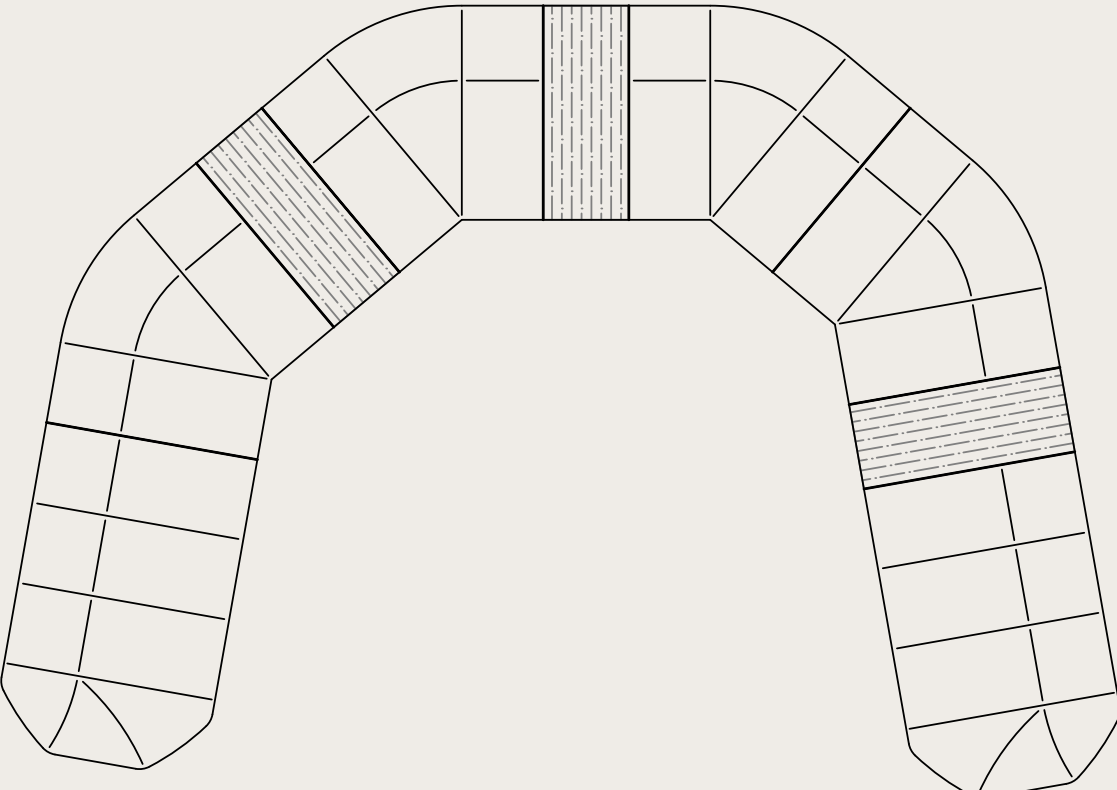

COMPOSITION 9

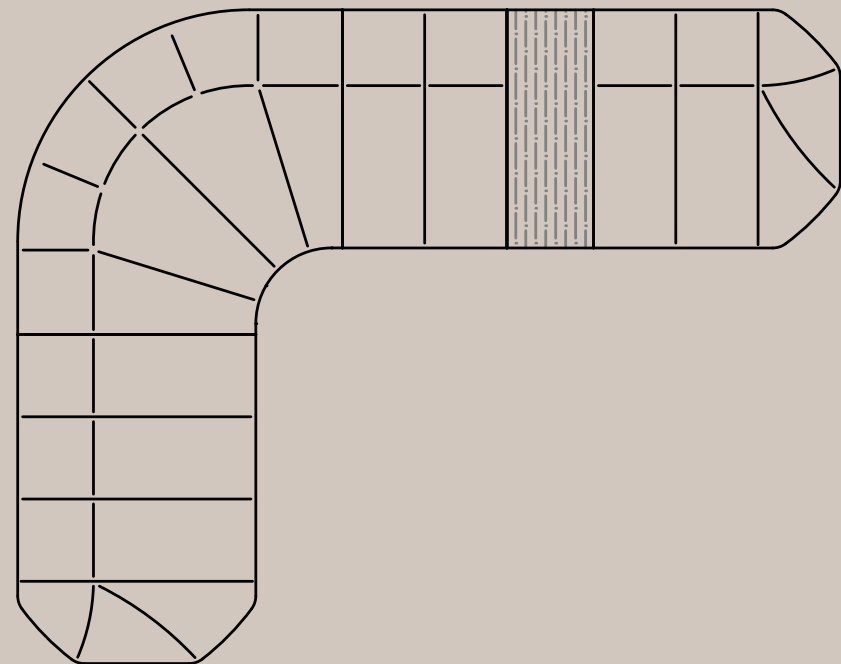

COMPOSITION 10

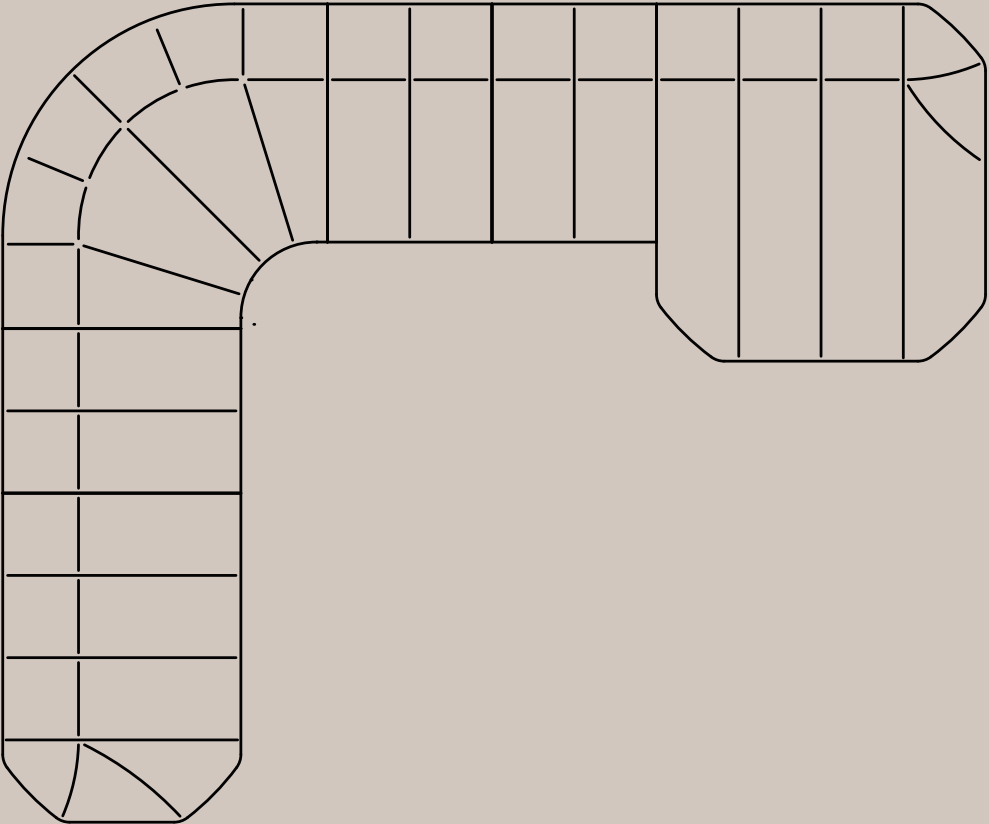

# Cloud Chaise Longue

DESIGN MASSIMO CASTAGNA



CLOUD CHAISE LONGUE | MASSIMO CASTAGNA



# Cloud Chaise Longue

DESIGN MASSIMO CASTAGNA

Chaise-longue armchair in non-deformable foam polyurethane in different density and polyester fibre with wooden inside structure. Black lacquered wooden feet. Available covered by fabric or leather as per sample. Not removable cover.

Additional stitching is required for elements with leather upholstery compared to elements with fabric upholstery.

## DIMENSIONS

Cm	Inches
160 x 165 x 75h	63" x 65" x 29¾"h

CLOUD CHAISE LONGUE | MASSIMO CASTAGNA

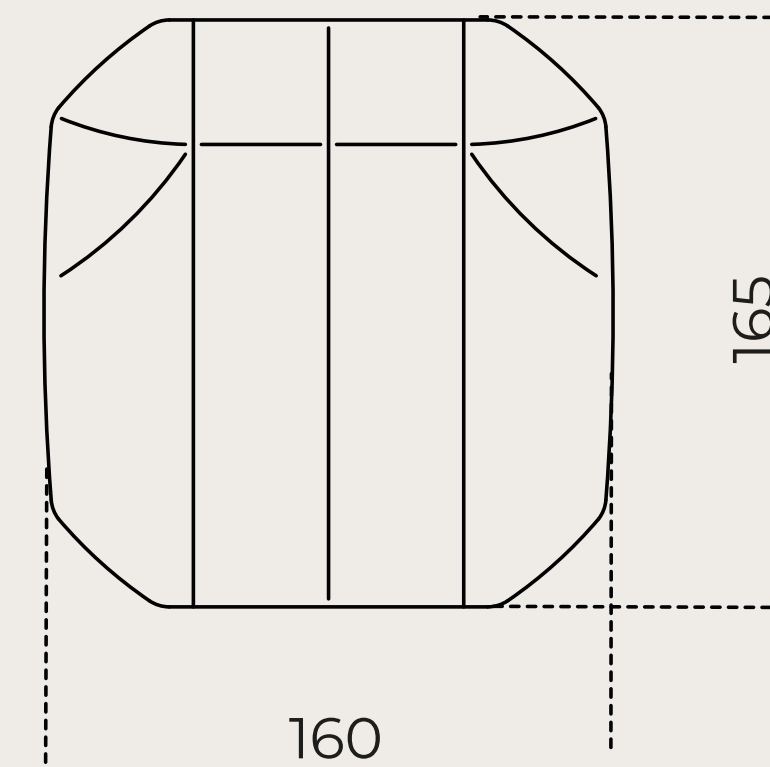
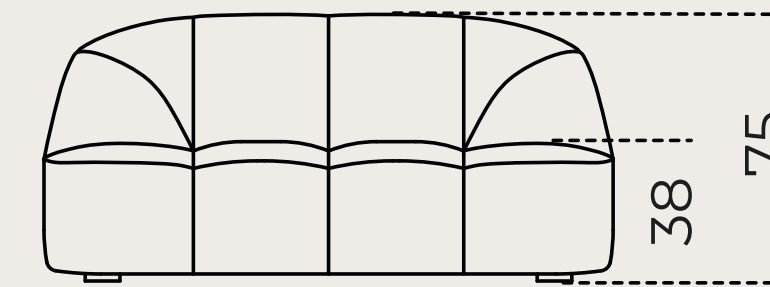



CLOUD CHAISE LONGUE | MASSIMO CASTAGNA

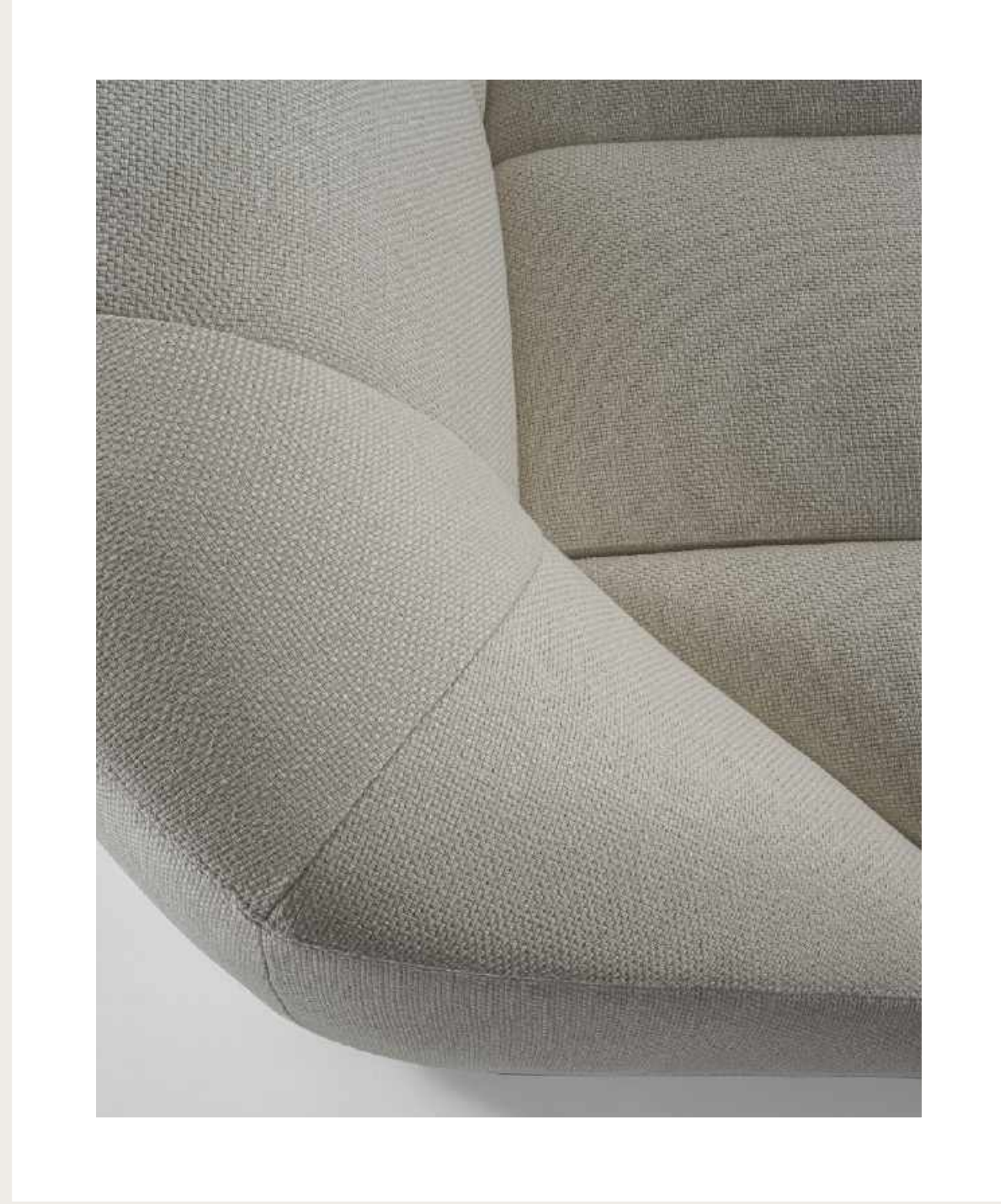

# Re — verre

DESIGN FEDERICA BIASI



RE-VERRE | FEDERICA BIASI

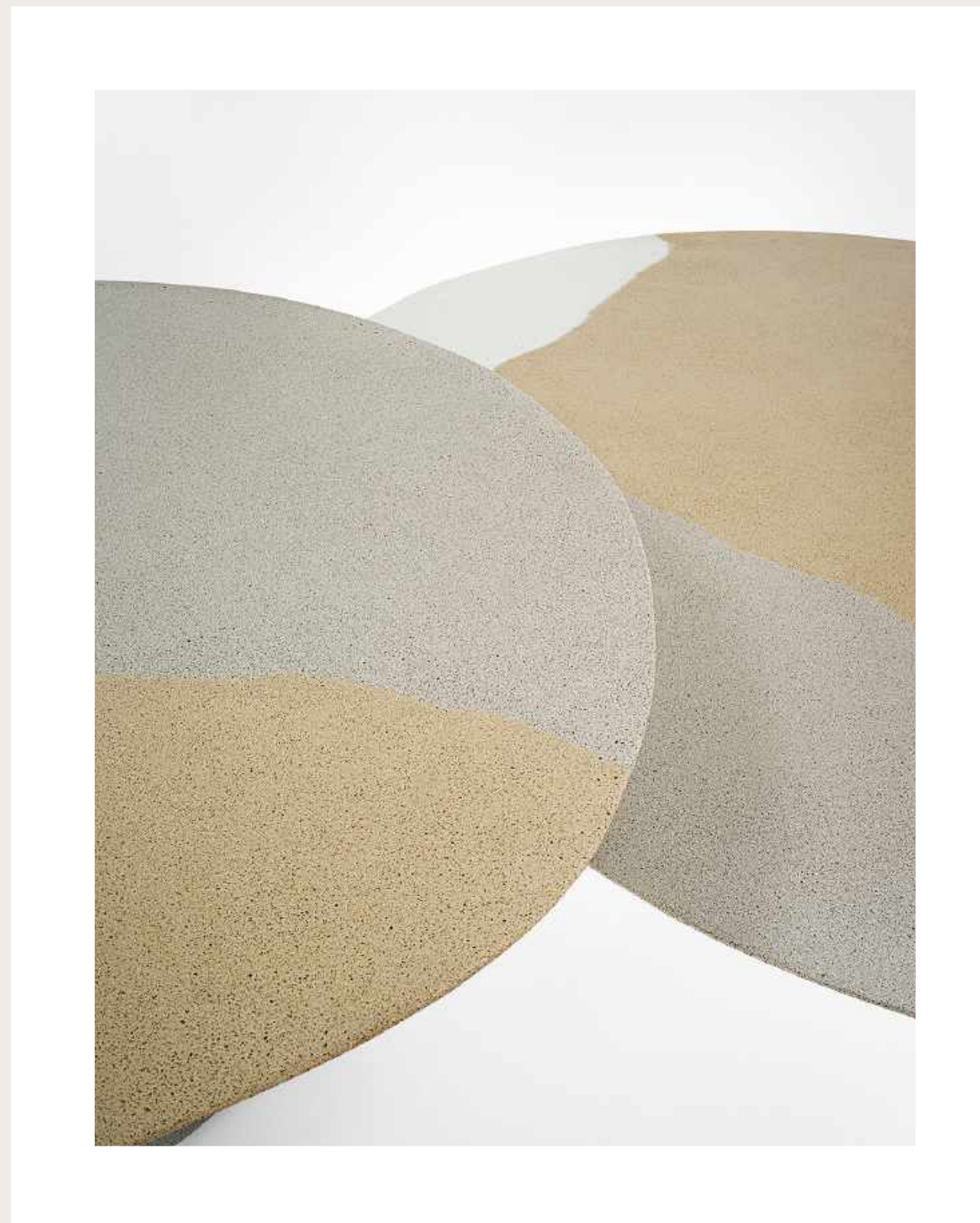

# Re — verre

DESIGN FEDERICA BIASI

Coffee table in recycled glass available in the following finishes:

"melange terre" ("terre cuite" orange, "noisette" brown and "chocolat" brown) with "chocolat" brown base or "mélange lunaire" ("blanc" white, "sable" beige and "roche" grey) with "roche" grey base.

Also available monochromatic version "chocolat" brown or "roche" grey.

Since this is an artisanal and manual process, the measurements are indicative and the surface may be porous and not completely flat.

## DIMENSIOIS

Cm	Inches
Ø50 x 50	Ø19¾" x 19¾"
Ø60 x 47	Ø23¾" x 18¾"
Ø90 x 37	Ø35½" x 14¾"
Ø120 x 27	Ø47¼" x 10¾"

## FINISHES



MELANGE TERRE



MELANGE LUNAIRE

RE-VERRE | FEDERICA BIASI

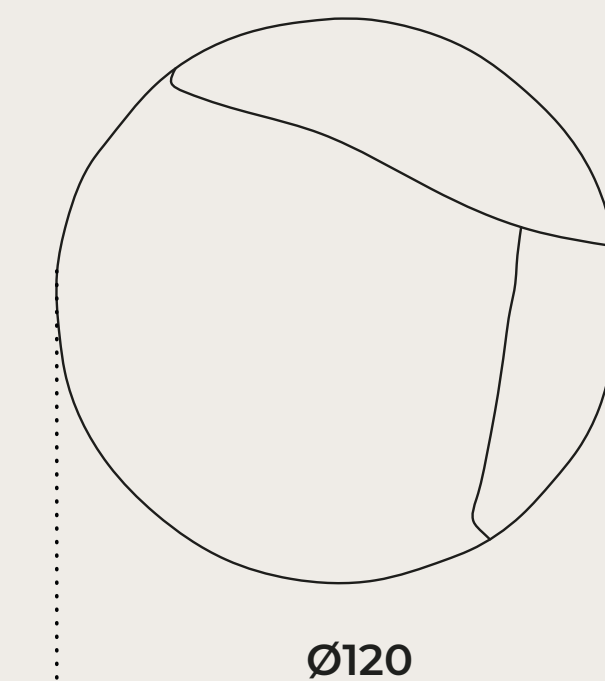
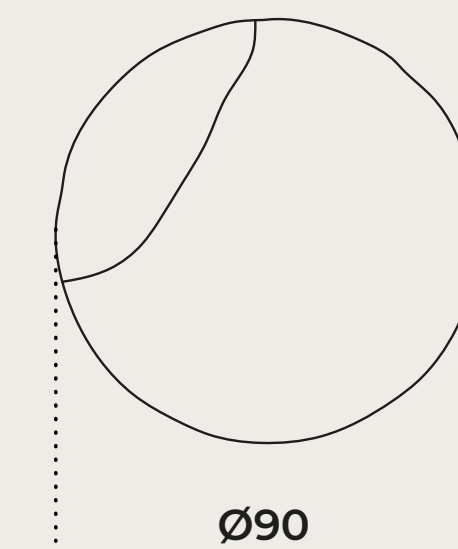
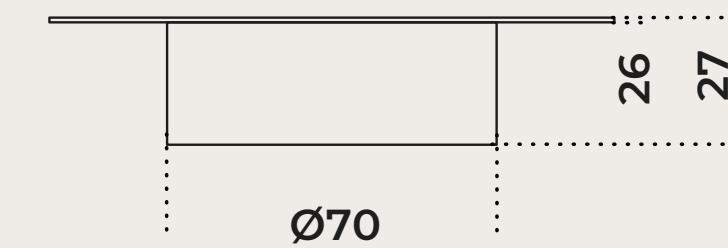
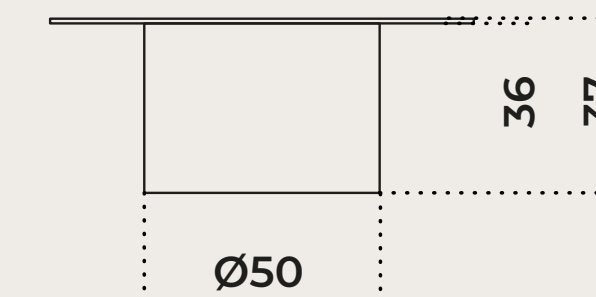
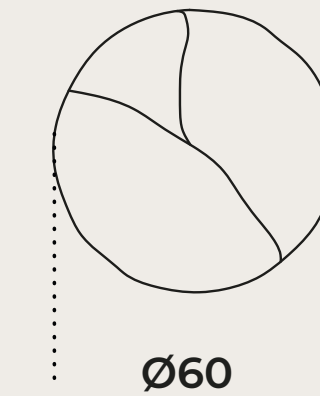
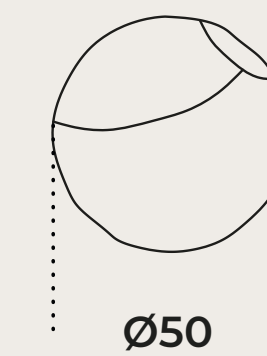
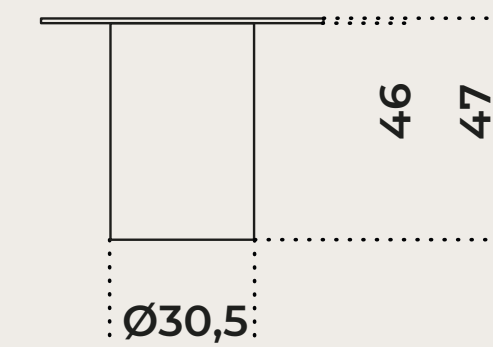
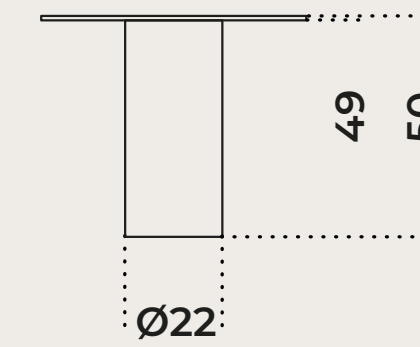

# Stami Loveseat

DESIGN STUDIOPEPE



STAMI LOVESEAT | STUDIOPEPE

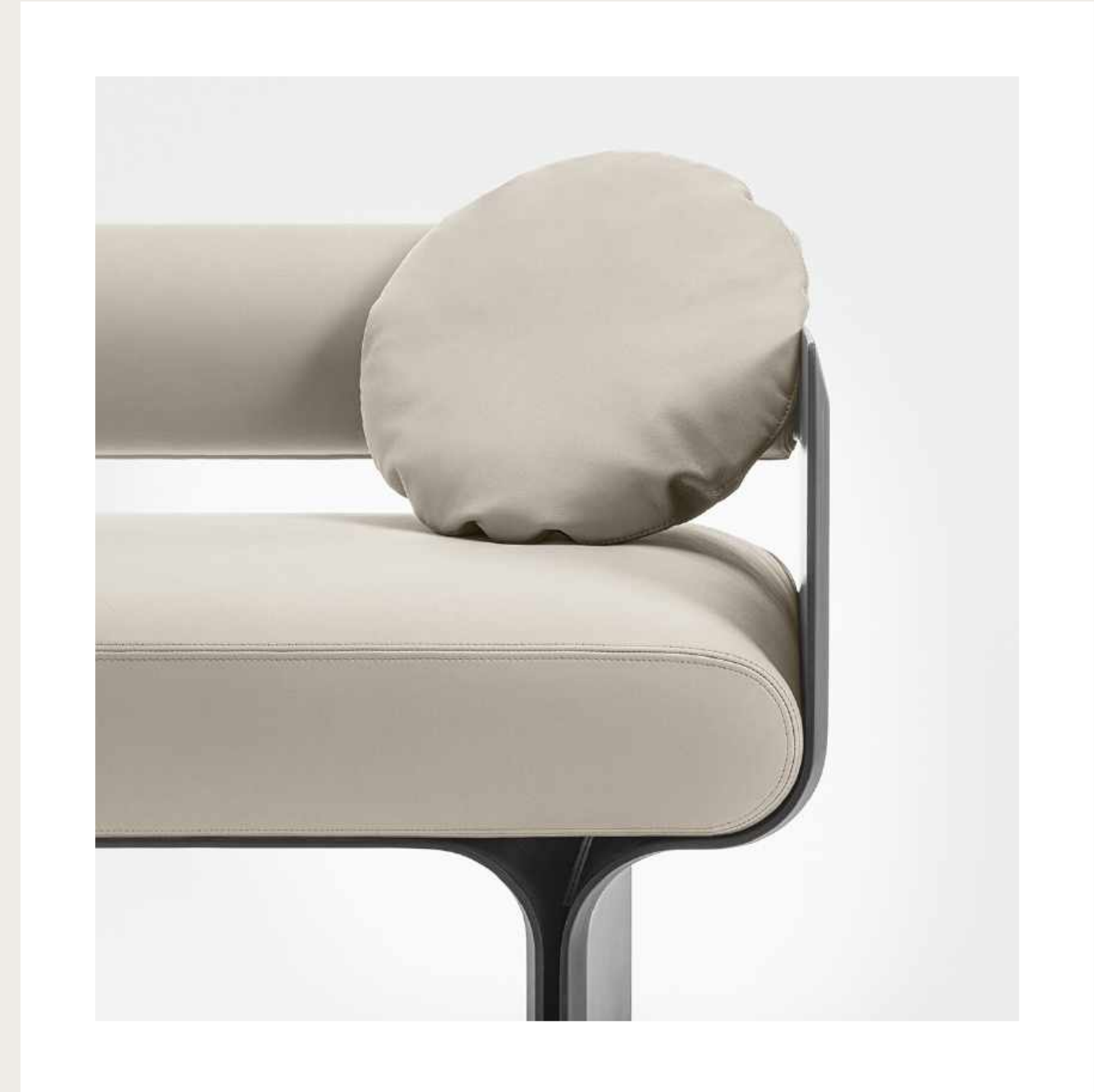

# Stami Loveseat

DESIGN STUDIOPEPE

Small sofa with curved black open pore stained ash base and bright brass details. Also available opaque lacquered wooden version in the colours "Rosso Persia", "Grigio Londra", "Nero Giza", "Bianco Camargue", "Verde Provenza", "Blu Pacifico", "Bordeaux Etruria", "Rosa Jaipur" and "Sabbia del Nilo".

Padding in polyurethane foam covered by fabric or leather as per samples. Removable cover.

Two diam. 38 cm downpadding cushion covered in the same finish of the armchair included.

Additional stitching is required for elements with leather upholstery compared to elements with fabric upholstery.

## DIMENSIONS

Cm	Inches
121 x 67,5 x 69,5	47¾ x 26¾" x 27½"
2 x cushions Ø38	2 x cushions Ø15"

## STRUCTURE FINISH

OPEN PORE STAINED	OPAQUE LACQUERED	OPAQUE LACQUERED	OPAQUE LACQUERED	OPAQUE LACQUERED
				
BLACK OPEN PORE	ROSSO PERSIA	GRIGIO LONDRA	NERO GIZA	BIANCO CAMARGUE
OPAQUE LACQUERED	OPAQUE LACQUERED	OPAQUE LACQUERED	OPAQUE LACQUERED	OPAQUE LACQUERED
				
VERDE PROVENZA	BLU PACIFICO	BORDEAUX ETRURIA	ROSA JAIPUR	SABBIA DEL NILO

STAMI LOVESEAT | STUDIOPEPE

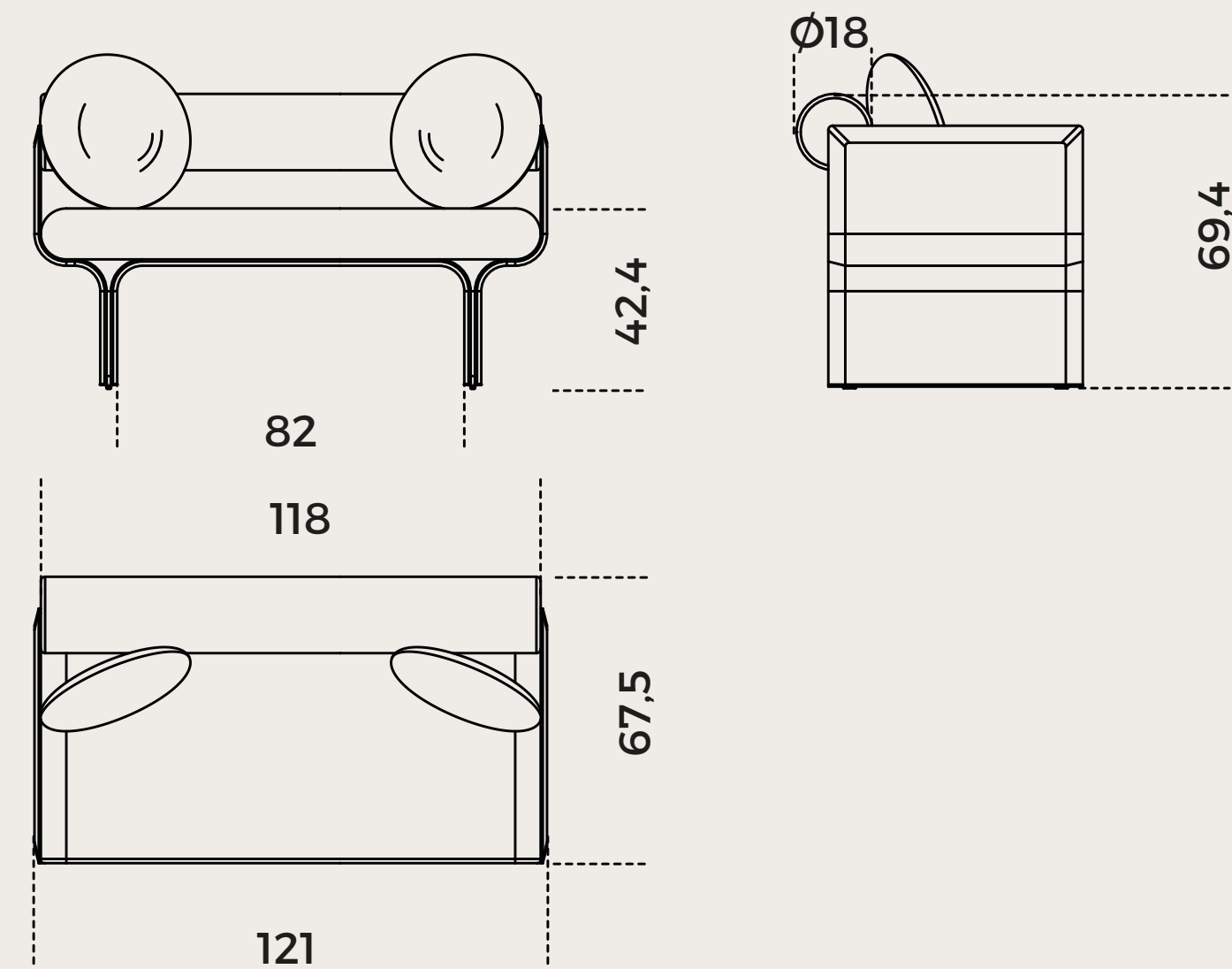



# Sensei Console

DESIGN TOLLGARD + CASTELLANI



SENSEI CONSOLE | TOLLGARD + CASTELLANI

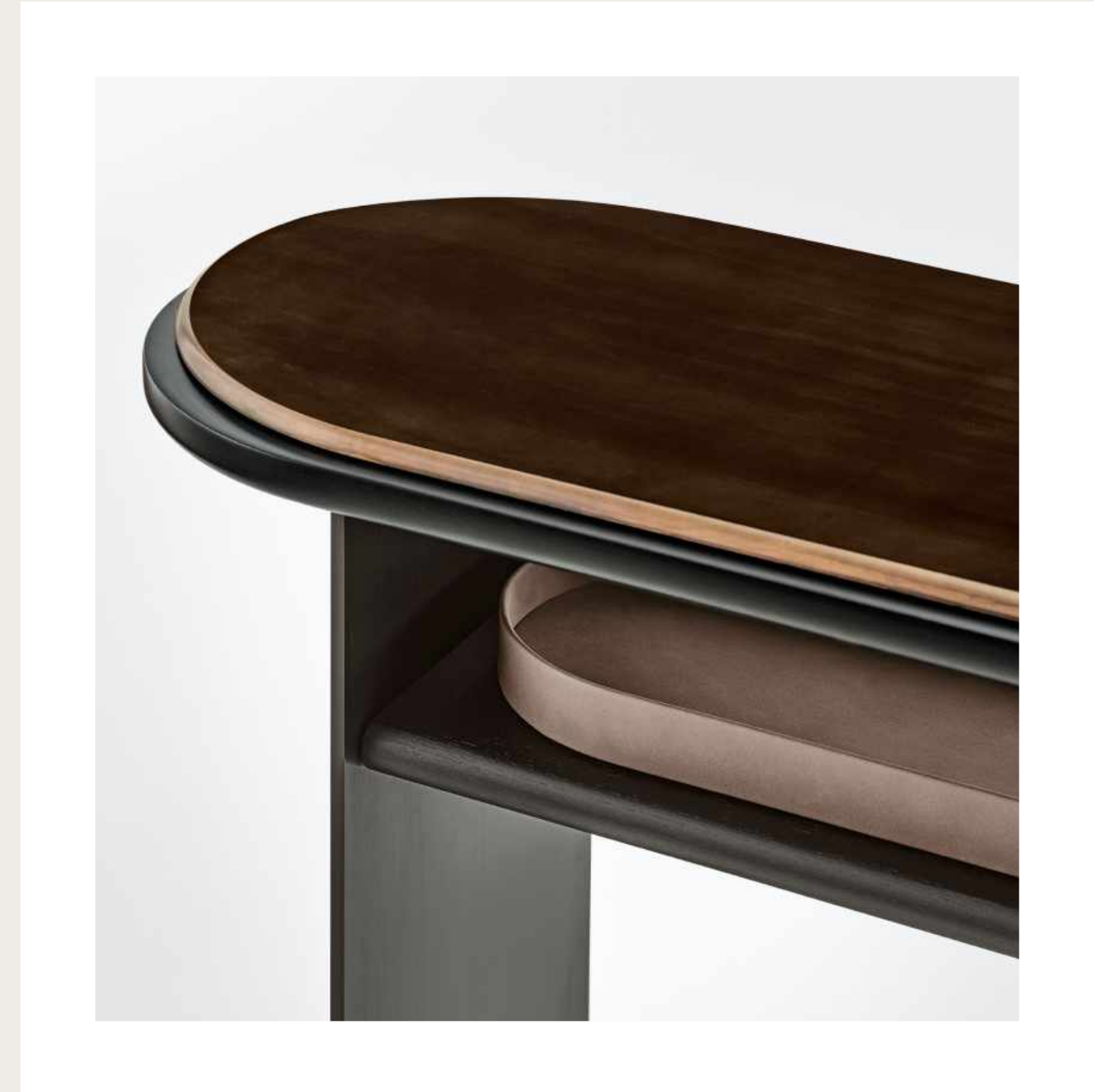

# Sensei Console

DESIGN TOLLGARD + CASTELLANI

Console with "deep black" lacquered metal structure and wooden top. Black open pore stained ash shelf and back. Resting on the wooden top, 12mm glass top with half bull-nose grinding in the exclusive finish "Rosso Marte" or painted as per samples in the bright version. Also available with 20mm natural polished Calacatta Vagli Oro marble, brushed Ceppo di Gré®, satin Arabescato Orobico Rosso, brushed Bianco Carrara Gioia or **satin Dover White**.

Lounge version height cm 65, available on request.

Metal accessories tray covered by leather fard as per samples, on request.

## DIMENSIONS

### GLASS TOP

Cm	Inches
150 x 35 x 65h	59¼" x 14" x 25¾"h
150 x 35 x 80h	59¼" x 14" x 31½"h
180 x 35 x 65h	71" x 14" x 25¾"h
180 x 35 x 80h	71" x 14" x 31½"h

### MARBLE TOP

Cm	Inches
150 x 35 x 65h	59¼" x 14" x 25¾"h
150 x 35 x 80h	59¼" x 14" x 31½"h
180 x 35 x 65h	71" x 14" x 25¾"h
180 x 35 x 80h	71" x 14" x 31½"h

SENSEI CONSOLE | TOLLGARD + CASTELLANI

## Piano in cristallo

Glass top

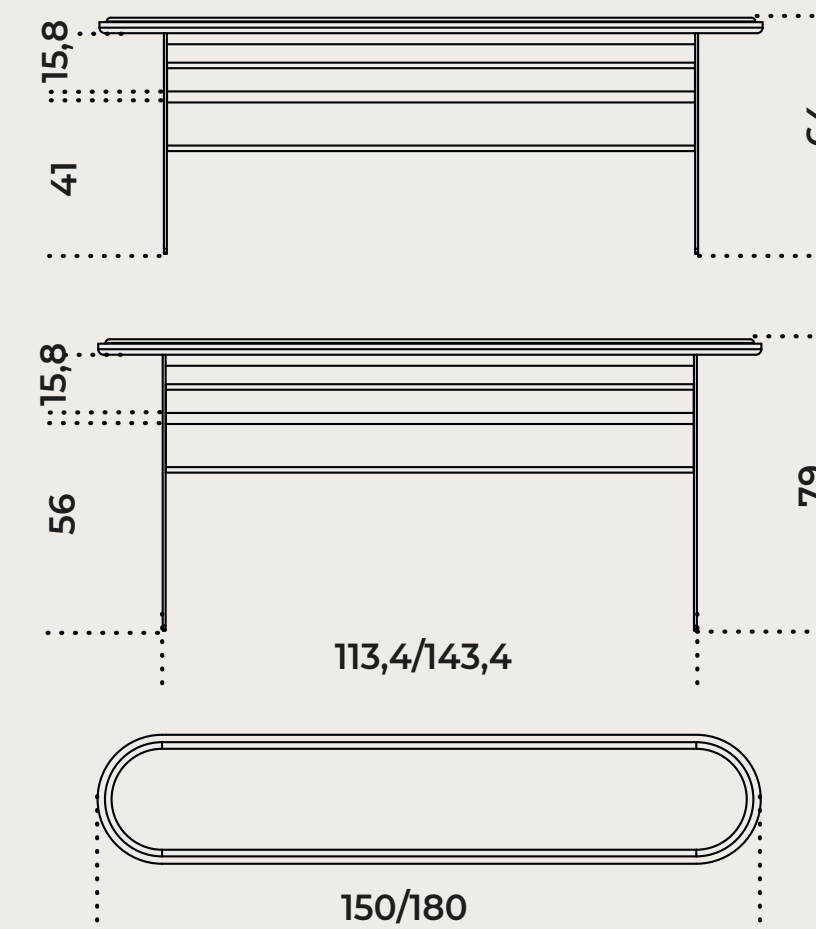

## Piano in marmo

Marble top

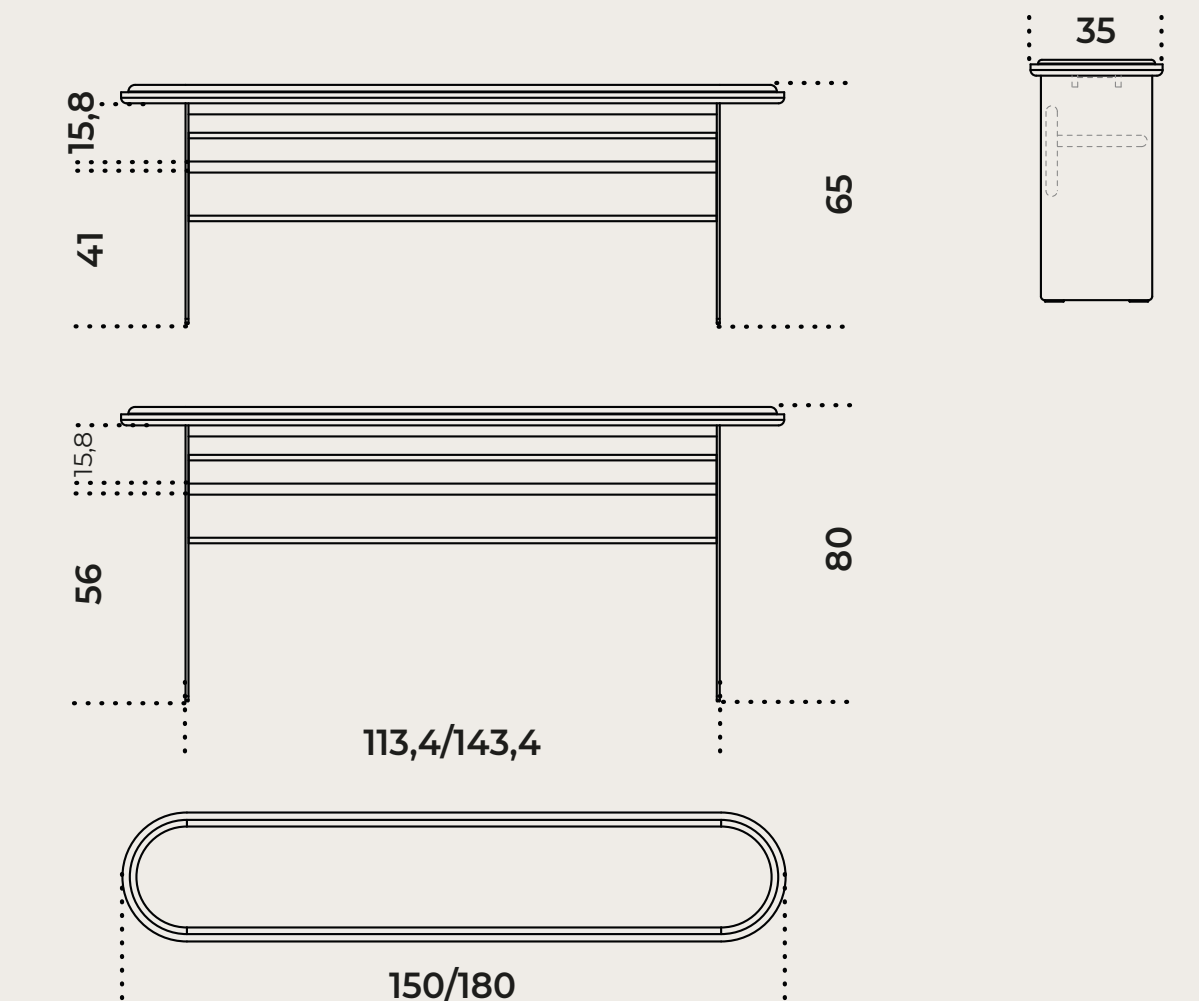

**STRUCTURE**



**GLASS TOP**

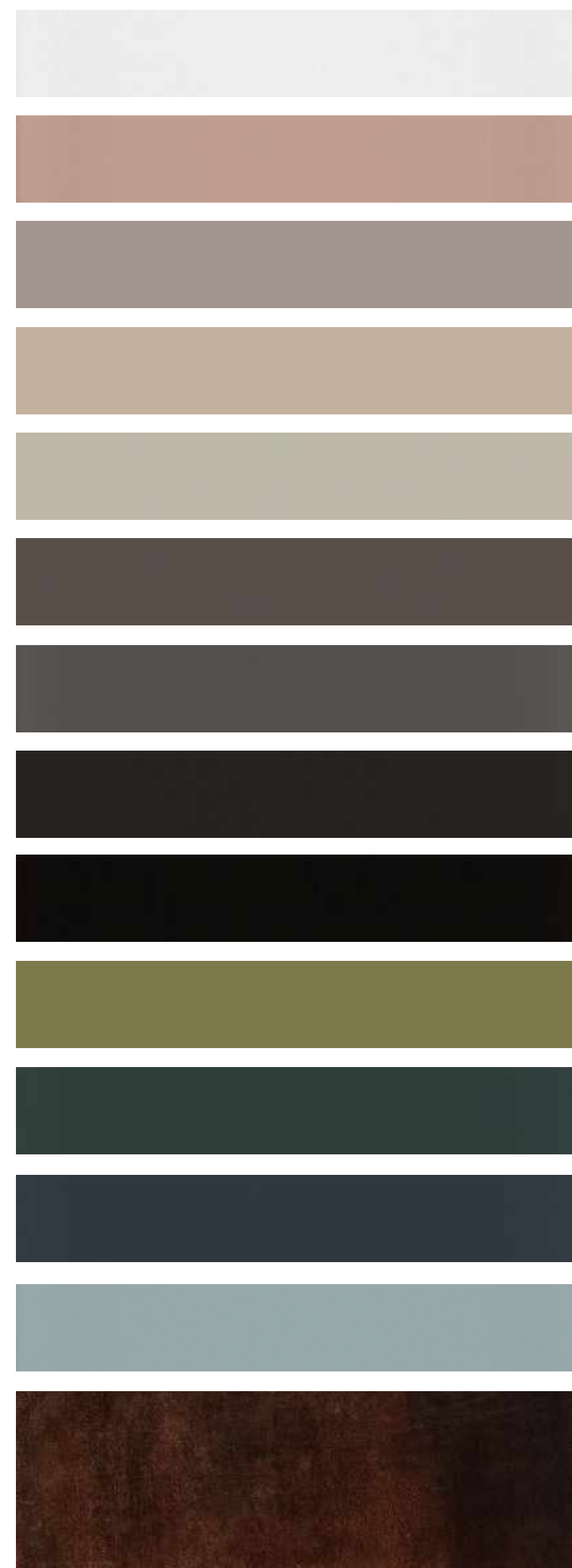

Bianco bright

Cipria bright

Visone bright

Champagne bright

Cemento bright

Grigio beige bright

Grigio umbro bright

Liquirizia bright

Nero bright

Oliva bright

Verde grigio bright

Blu grigio bright

Cadet grigio bright

Rosso Marte



**STRUCTURE**



**MARBLE TOP**



Natural Polished  
Calacatta Vagli Oro



Brushed  
Ceppo di Gré®



Satin Arabescato  
Orobico Rosso



Brushed Bianco  
Carrara Gioia



**NEW**  
Satin Dover White



# Sensei

DESIGN TOLLGARD + CASTELLANI



SENSEI | TOLLGARD + CASTELLANI



# Sensei

DESIGN TOLLGARD + CASTELLANI

Coffee table with "deep black" lacquered metal structure and wooden top. Resting on the wooden top, 12mm glass top with half bull-nose grinding in the exclusive finish "Rosso Marte" or painted as per samples in the bright version. Also available with 20mm natural polished Calacatta Vagli Oro marble, brushed Ceppo di Gré®, satin Arabescato Orobico Rosso, brushed Bianco Carrara Gioia or **satin Dover White**. The coffee table A is made exclusively with recessed wooden top.

## DIMENSIONS

### WOODEN TOP WITH RECESS

Cm	Inches
A 130 x 25 x 43h	51¼" x 10" x 17"h

### MARBLE TOP

Cm	Inches
B 160 x 25 x 35h	63" x 10" x 14"h
C 180 x 45 x 35h	71" x 17¾" x 14"h
D 140 x 85 x 25h	55¼" x 33½" x 10"h
E Ø45 x 42,9h	Ø17¾" x 17"h
F Ø100 x 24,9h	Ø39½" x 10"h
G Ø100 x 35,4h	Ø39½" x 14"h

### GLASS TOP

Cm	Inches
B 160 x 25 x 34,5h	63" x 10" x 13¾"h
C 180 x 45 x 34,5h	71" x 17¾" x 13¾"h
D 140 x 85 x 24,5h	55¼" x 33½" x 9¾"h
E Ø45 x 42,1h	Ø17¾" x 16¾"h
F Ø100 x 24,1h	Ø39½" x 9½"h
G Ø100 x 34,6h	Ø39½" x 13¾"h

SENSEI | TOLLGARD + CASTELLANI

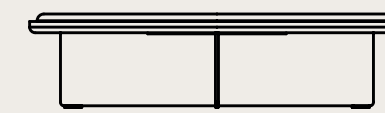
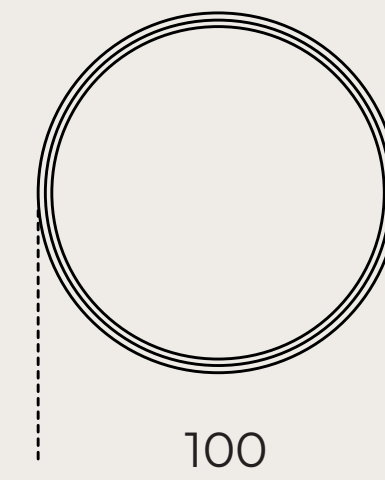

F

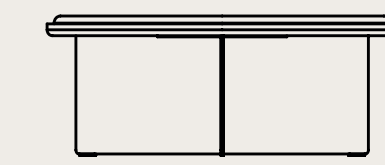
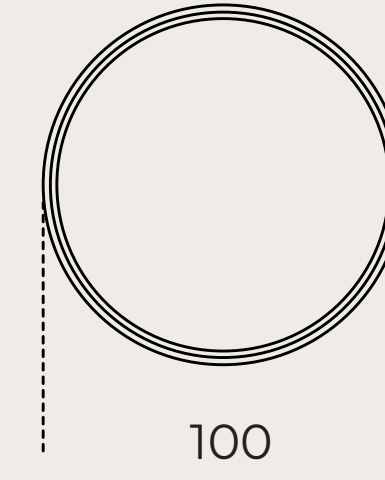

G

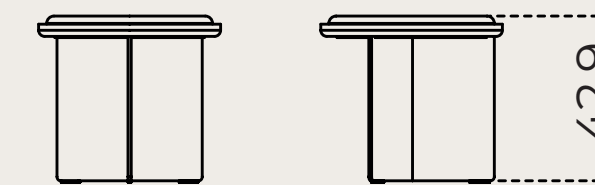
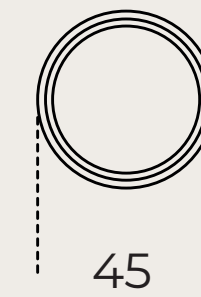

E

WOODEN TOP WITH RECESS

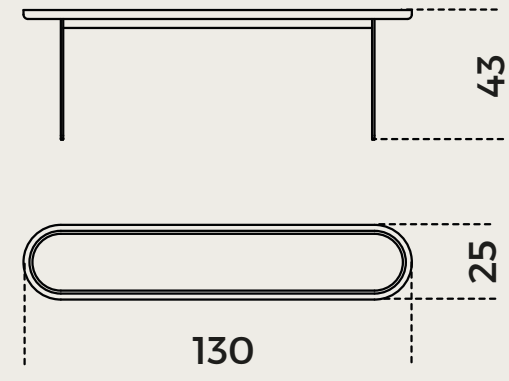

**A**

MARBLE TOP

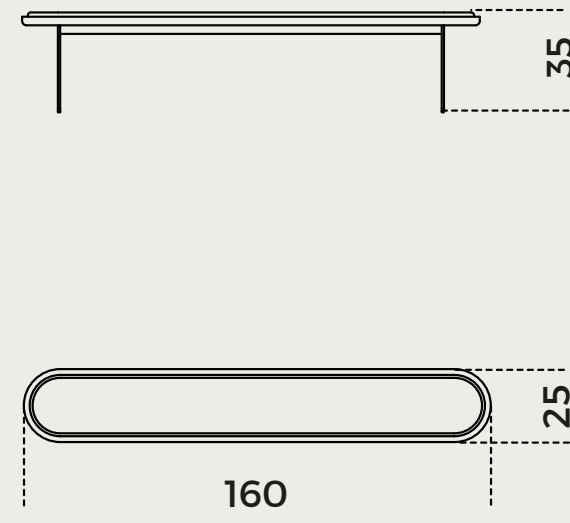

**B**

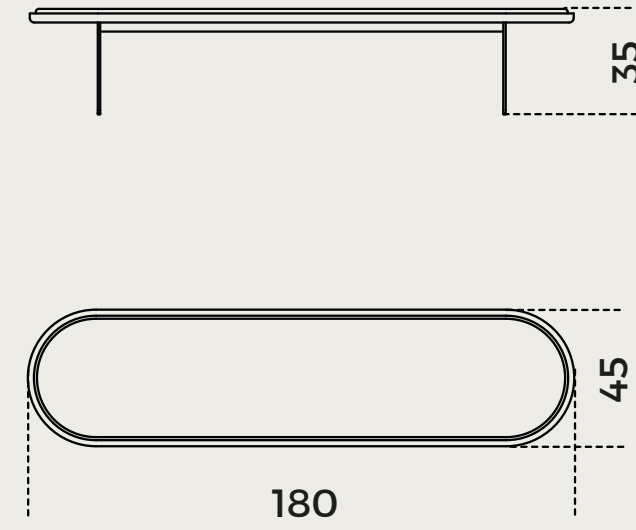

**C**

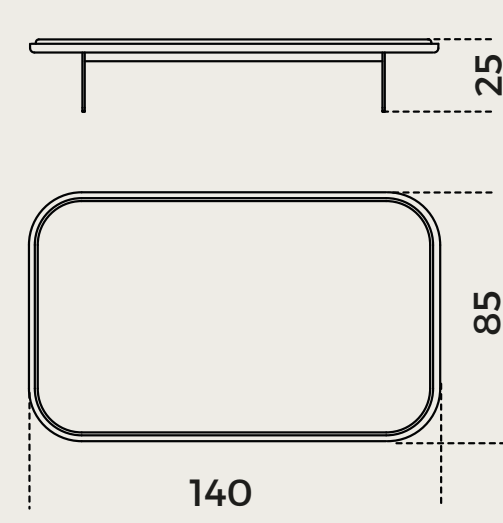

**D**

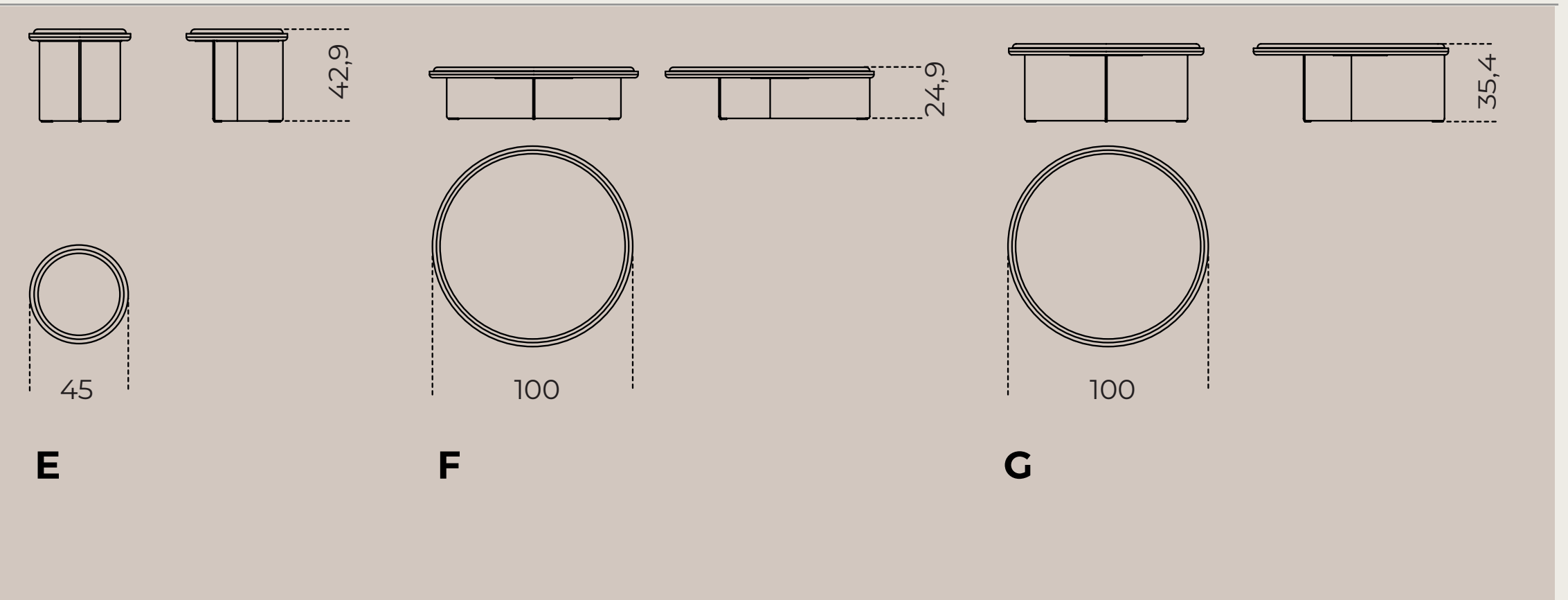

**E**

**F**

**G**

GLASS TOP

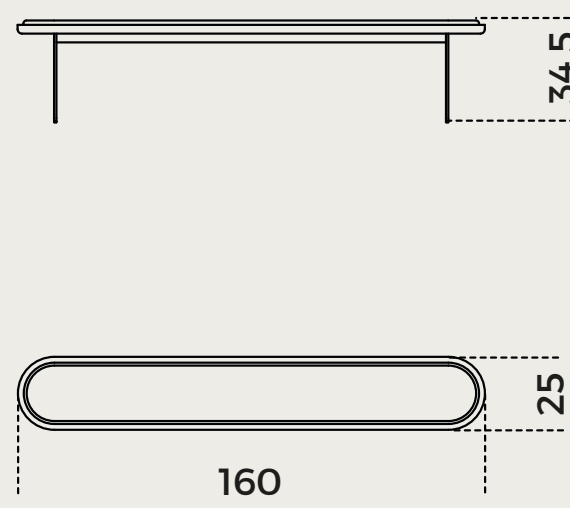

**B**

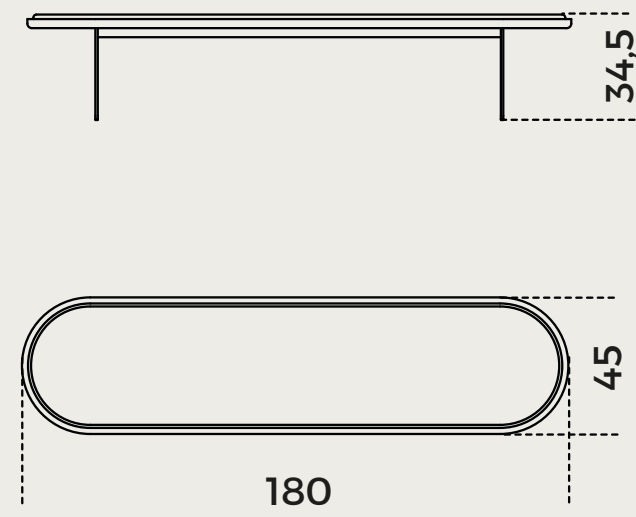

**C**

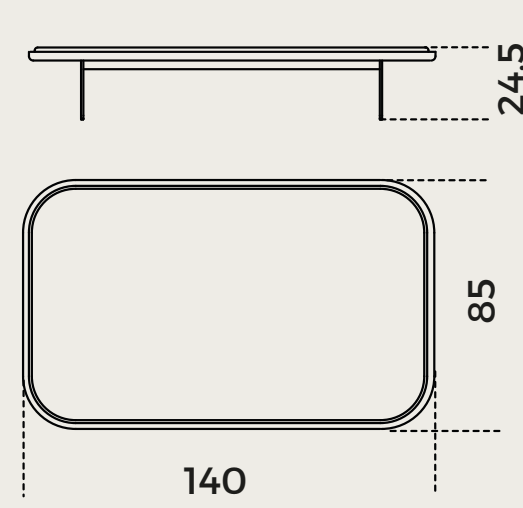

**D**

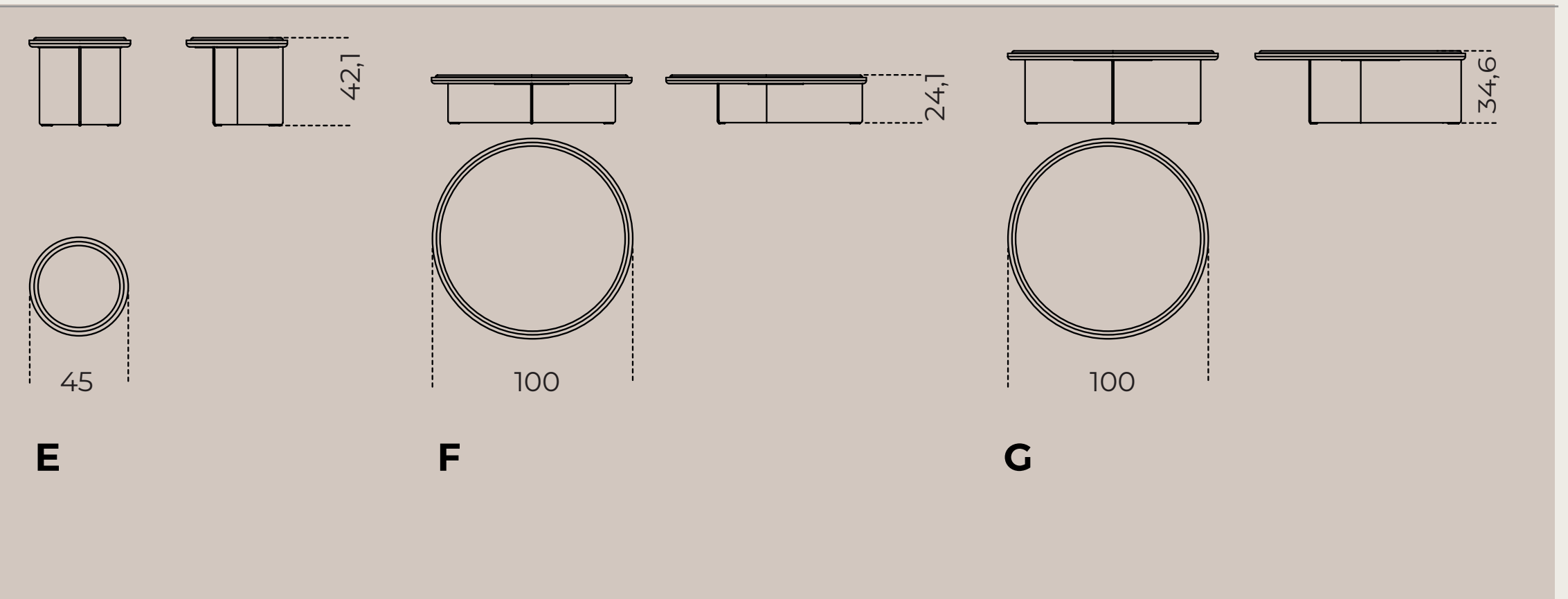

**E**

**F**

**G**

**MARBLE TOP:**

POLISHED CALACATTA VAGLI ORO

BRUSHED CEPPPO DI GRÉ

SATIN ARABESCATO OROBICO ROSSO

BRUSHED BIANCO CARRARA GIOIA

SATIN DOVER WHITE

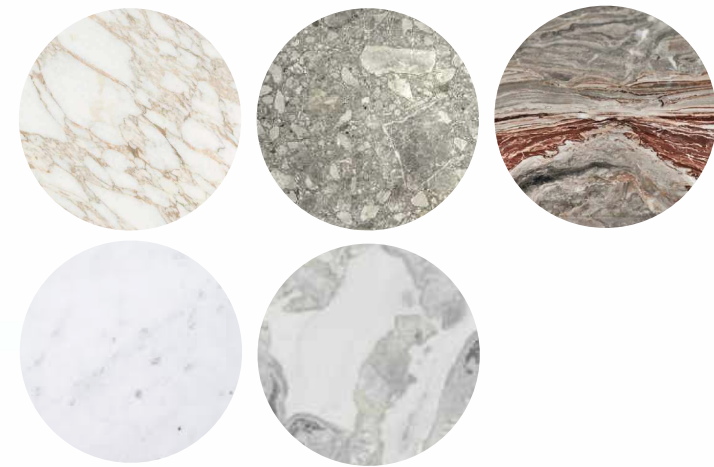

**GLASS TOP:**

EXCLUSIVE ARTISANAL FINISH 'ROSSO MARTE'

BACKPAINTED GLOSSY GLASS IN ALL THE COLOURS OF THE COLLECTION

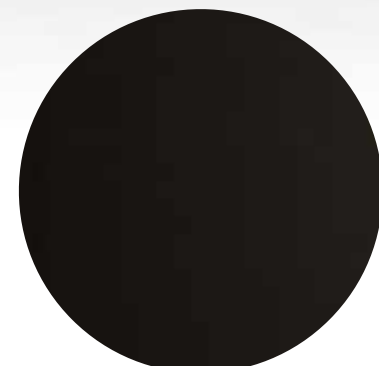
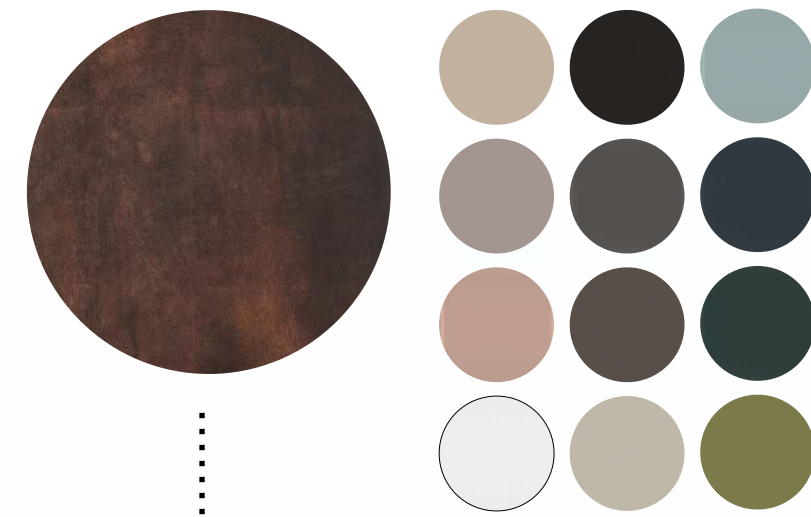

**STRUCTURE:**

METAL AND WOOD LACQUERED IN THE 'DEEP BLACK' COLOUR

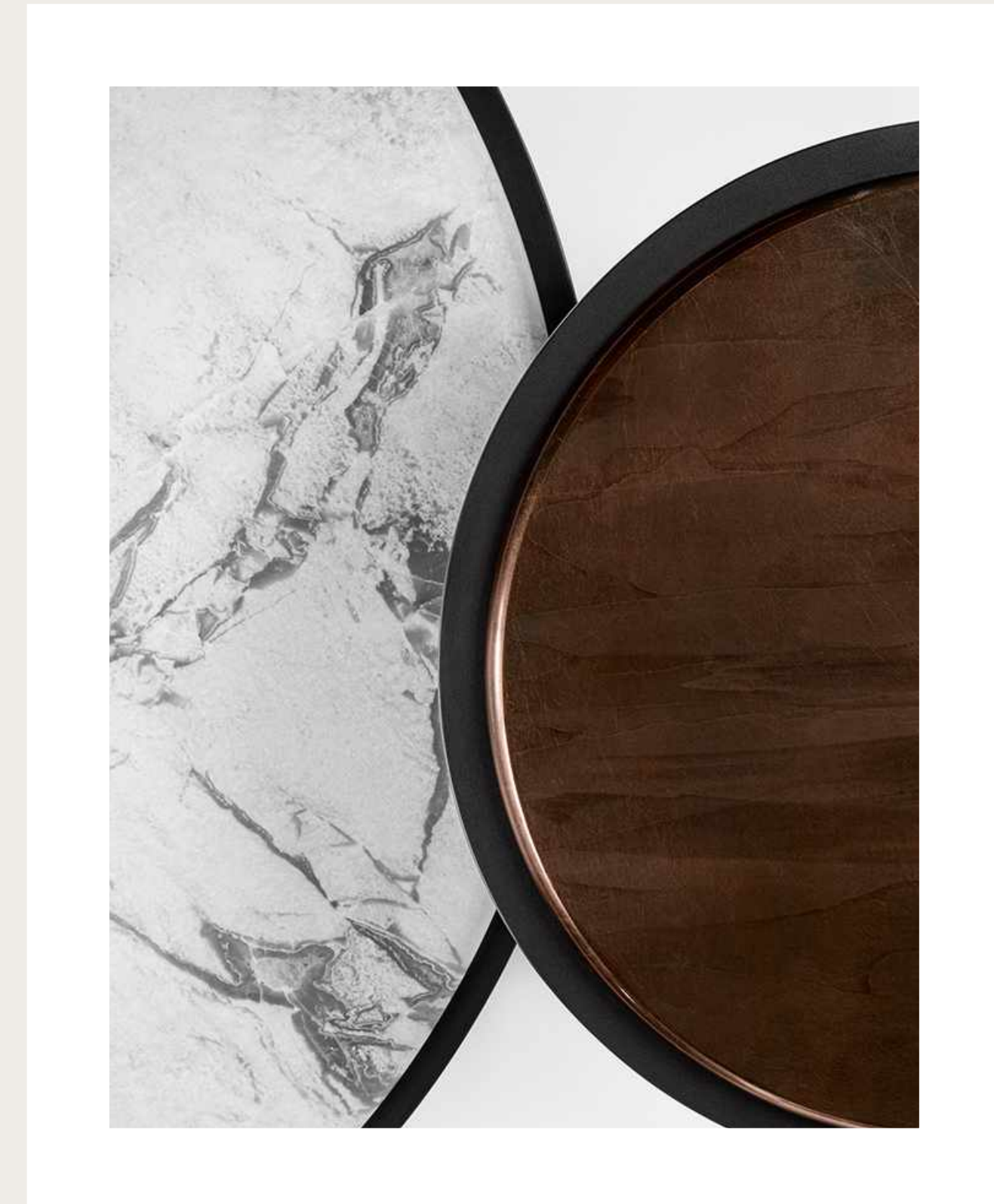



# Ato

DESIGN STUDIO G&R



ATO | STUDIO G&R

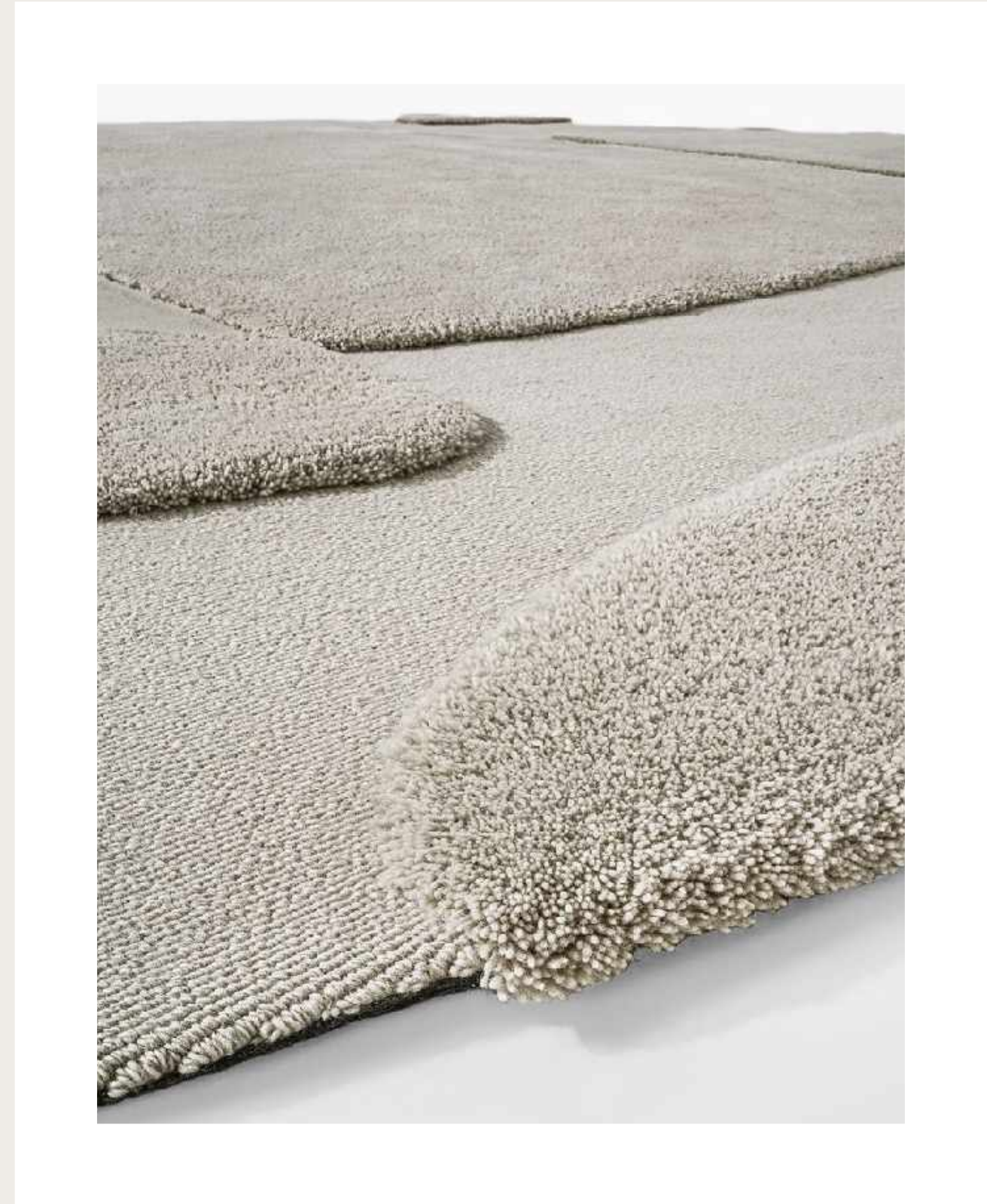

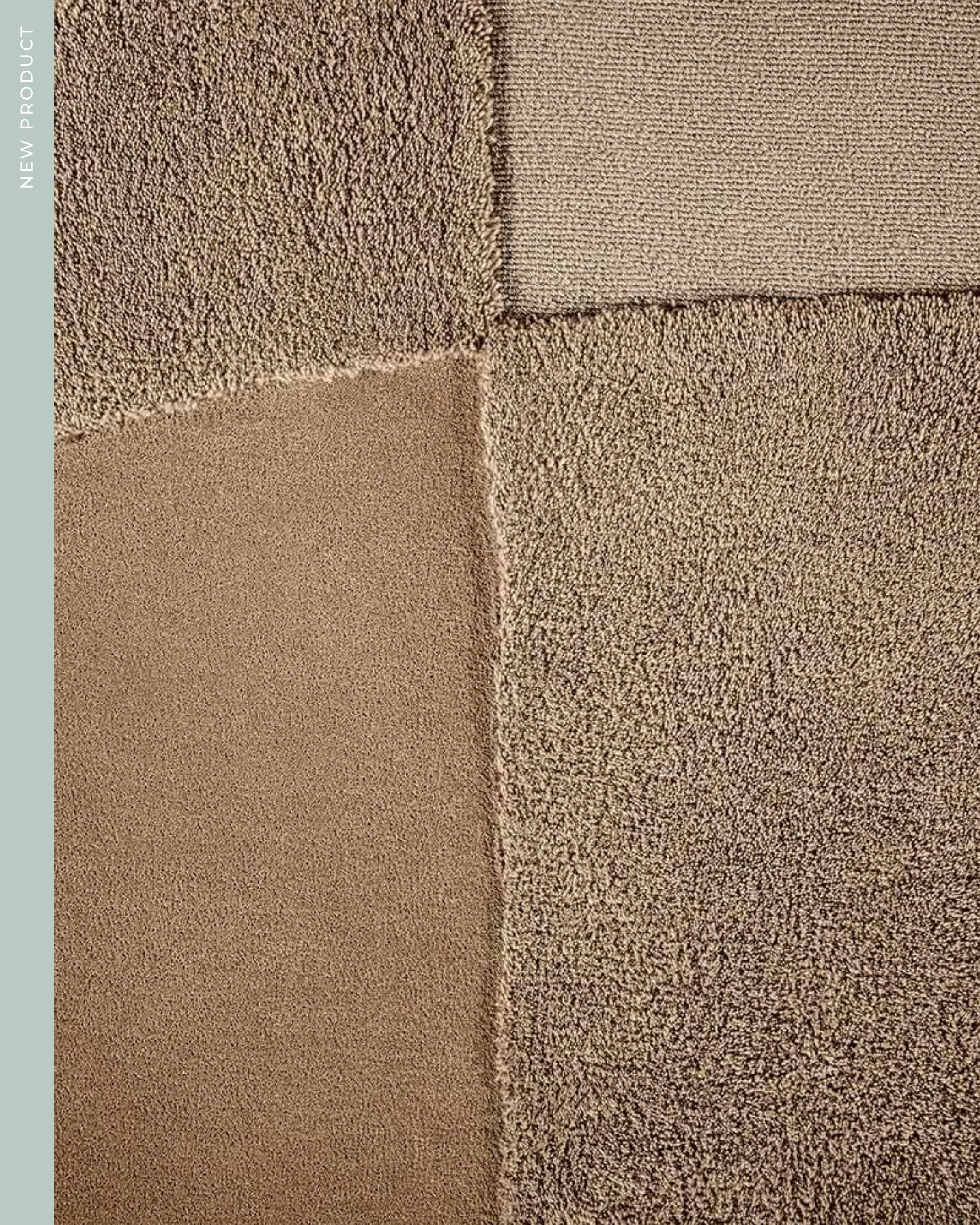

ATO | STUDIO C&R



# Ato

## DESIGN STUDIO G&R

Hand tufted rug made from New Zealand wool.  
Ato is characterized by an abstract geometric pattern that is created through differences in pile textures and heights. Available in the colors "dust", "sand" and "dune" made through natural dyes.

### DIMENSIONS

Cm	Inches
A 460 x 300	A 181¼" x 118¼"
B 485 x 410	B 191" x 161½"

### FINISHES



DUST

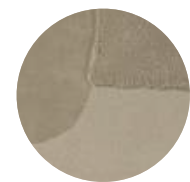

SAND



DUNE

ATO | STUDIO G&R

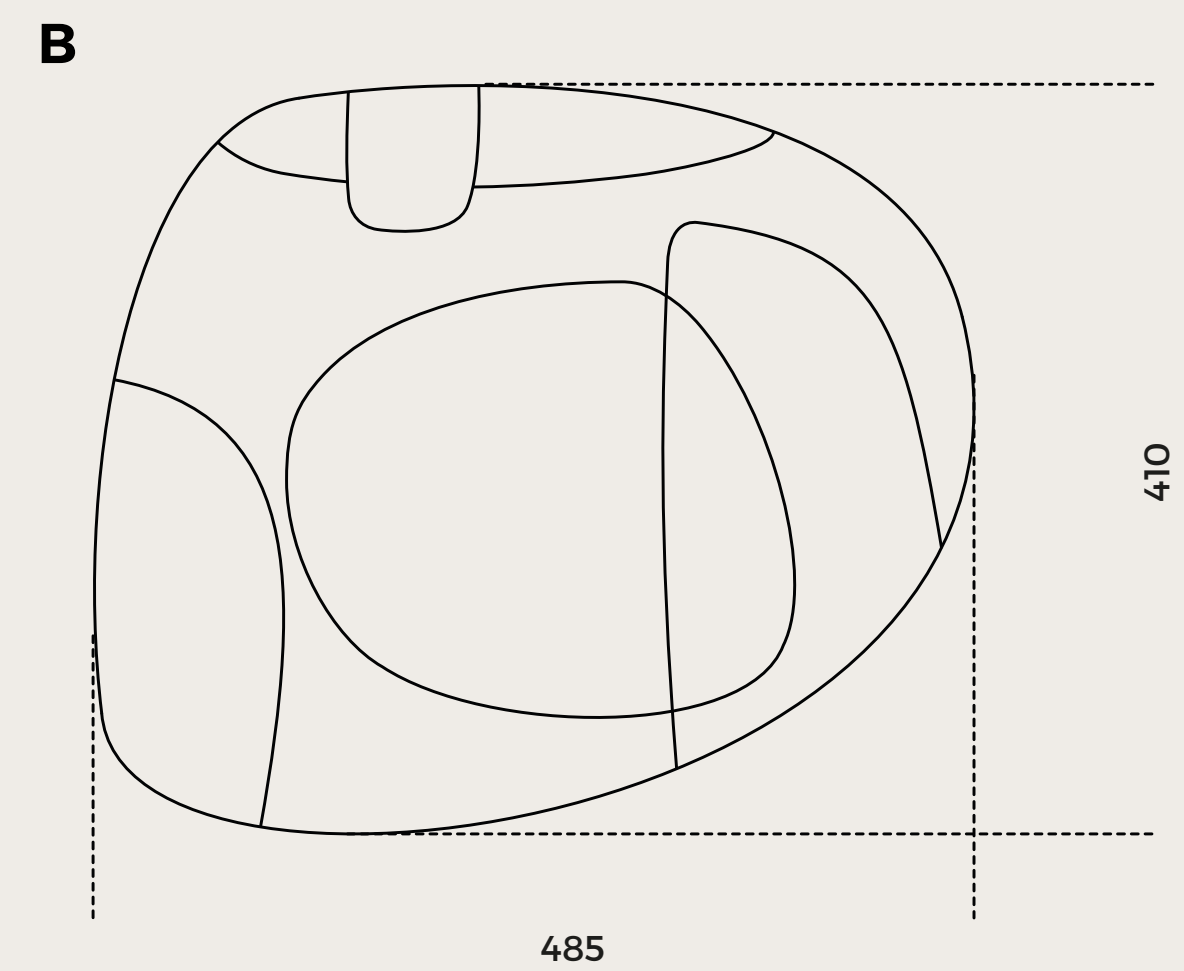
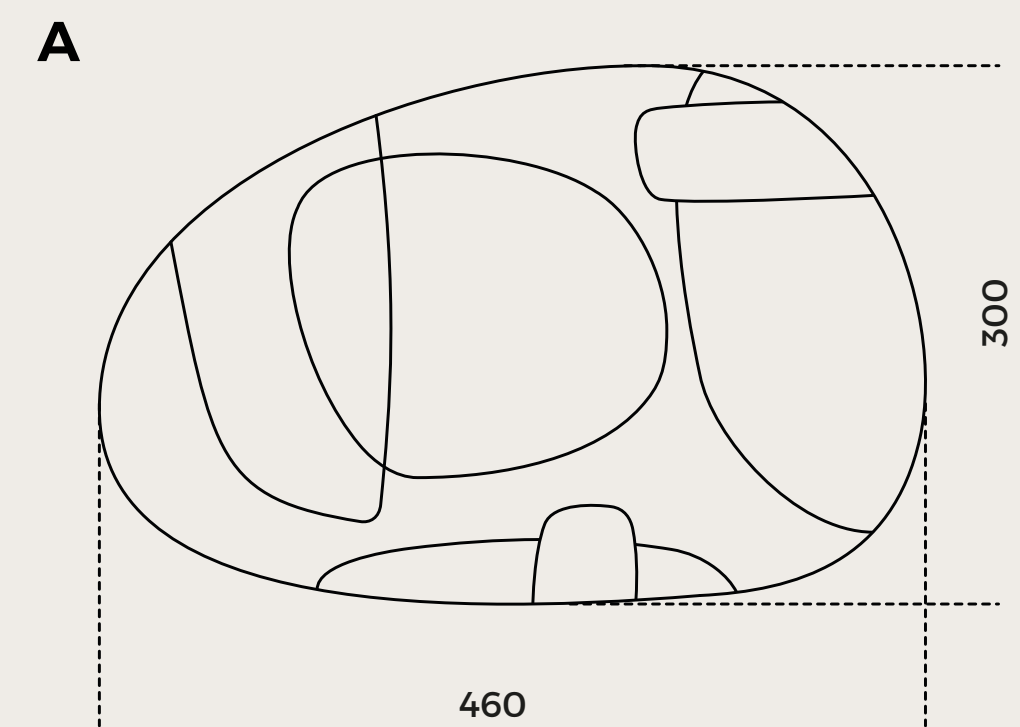

2024 COLLECTION

# BEDROOM

SALONE DEL  
MOBILE.MILANO  
2024





*BEDROOM*

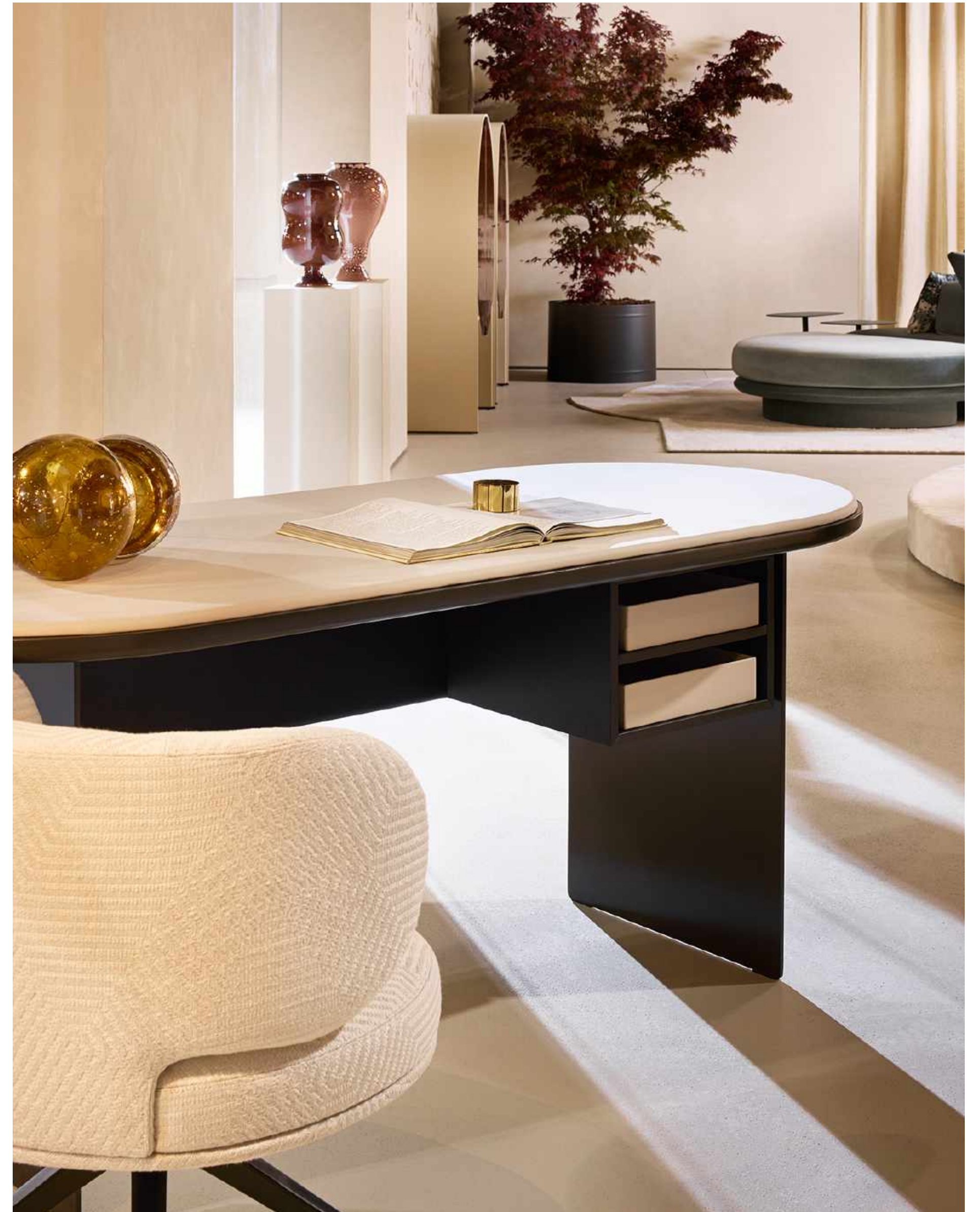

*BEDROOM*

# Sunrise

DESIGN STUDIOPEPE

SUNRISE | STUDIOPEPE

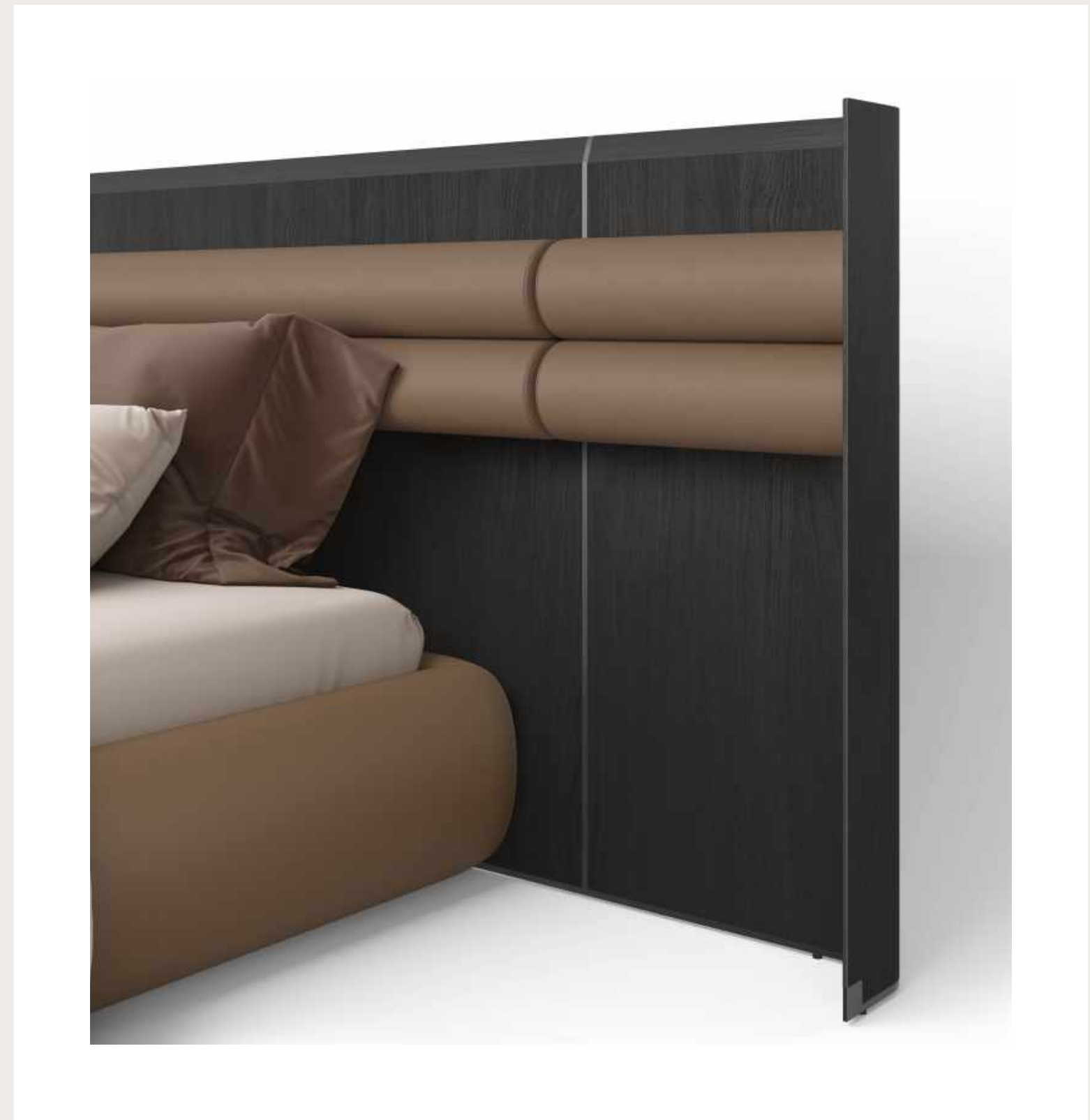

# Sunrise

## DESIGN STUDIOPEPE

Bed in non-deformable foam polyurethane in different density and polyester fibre. Curved black open pore stained freestanding headboard with headrest in non-deformable foam polyurethane. Also available opaque lacquered wooden version in the colours "Rosso Persia", "Grigio Londra", "Nero Giza", "Bianco Camargue", "Verde Provenza", "Blu Pacifico", "Bordeaux Etruria", "Rosa Jaipur" and "Sabbia del Nilo". Available covered by fabric or leather as per samples. Black nickel-plated metal details. Wooden slats included.

Removable bed frame. Removable headrest excluding Cat. L1, L2 and customer leather C.O.L.

Additional stitching is required for elements with leather upholstery compared to elements with fabric upholstery.

### DIMENSIONS

Cm	Inches
300 x 220 x 110h	181¼" x 86¾" x 43½"h
320 x 220 x 110h	126" x 86¾" x 43½"h
340 x 220 x 110h	134" x 86¾" x 43½"h
300 x 223 x 110h	181¼" x 88" x 43½"h
320 x 233 x 110h	126" x 91¾" x 43½"h
340 x 223 x 110h	134" x 88" x 43½"h

### STRUCTURE FINISH

<i>OPEN PORE STAINED</i>	<i>OPAQUE LACQUERED</i>	<i>OPAQUE LACQUERED</i>	<i>OPAQUE LACQUERED</i>	<i>OPAQUE LACQUERED</i>
				
BLACK OPEN PORE	ROSSO PERSIA	GRIGIO LONDRA	NERO GIZA	BIANCO CAMARGUE
<i>OPAQUE LACQUERED</i>	<i>OPAQUE LACQUERED</i>	<i>OPAQUE LACQUERED</i>	<i>OPAQUE LACQUERED</i>	<i>OPAQUE LACQUERED</i>
				
VERDE PROVENZA	BLU PACIFICO	BORDEAUX ETRURIA	ROSA JAIPUR	SABBIA DEL NILO

## SUNRISE | STUDIOPEPE

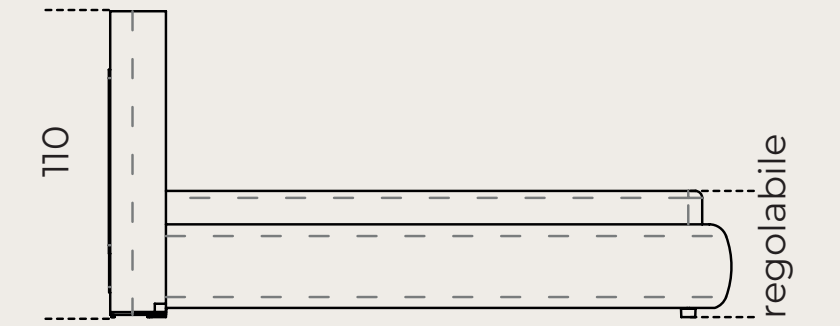
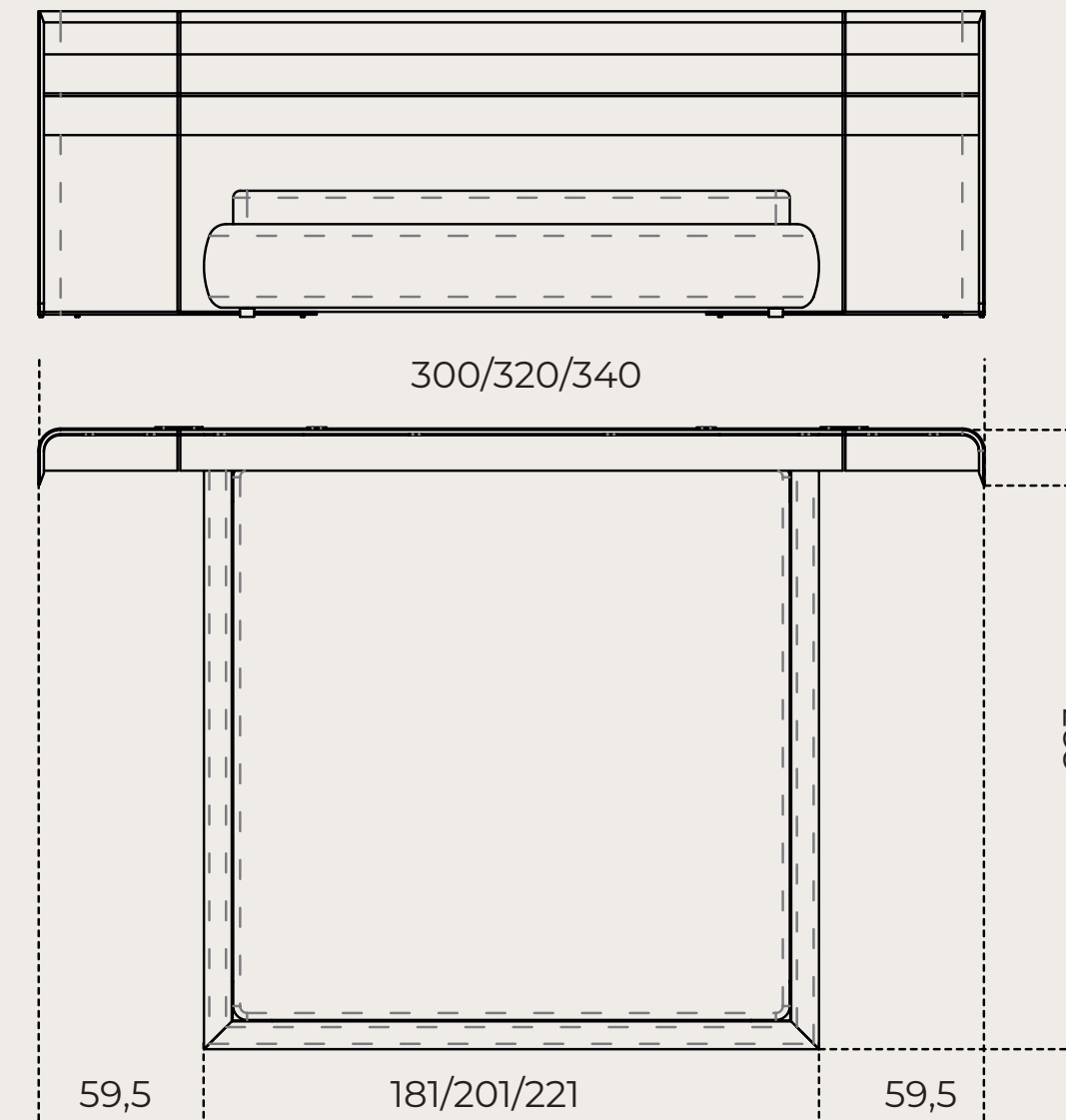



# Hide&Seek Mini

DESIGN PIETRO RUSSO



HIDE&SEEK MINI | PIETRO RUSSO



# Hide&Seek Mini



DESIGN PIETRO RUSSO

Coffee table with structure, rotating half-cylinder and shelf in glossy or opaque lacquered wood.  
Available colours: "Rosso Persia", "Grigio Londra", "Nero Giza", "Bianco Camargue", "Verde Provenza", "Blu Pacifico", "Bordeaux Etruria", "Rosa Jaipur" or "Sabbia del Nilo".

## DIMENSIONI

Cm	Inches
Ø47 x 44,5h	Ø18¾" x 17¾"h

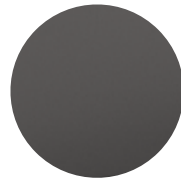
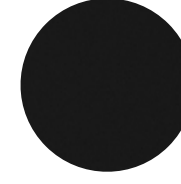
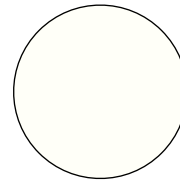
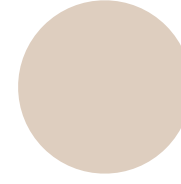
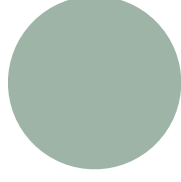
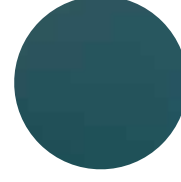
## FINISHES OF THE STRUCTURE

LACQUERED  ROSSO PERSIA	LACQUERED  GRIGIO LONDRA	LACQUERED  NERO GIZA	LACQUERED  BIANCO CAMARGUE	LACQUERED  SABBIA DEL NILO
LACQUERED  VERDE PROVENZA	LACQUERED  BLU PACIFICO	LACQUERED  BORDEAUX ETRURIA	LACQUERED  ROSA JAIPUR	

HIDE&SEEK MINI | PIETRO RUSSO

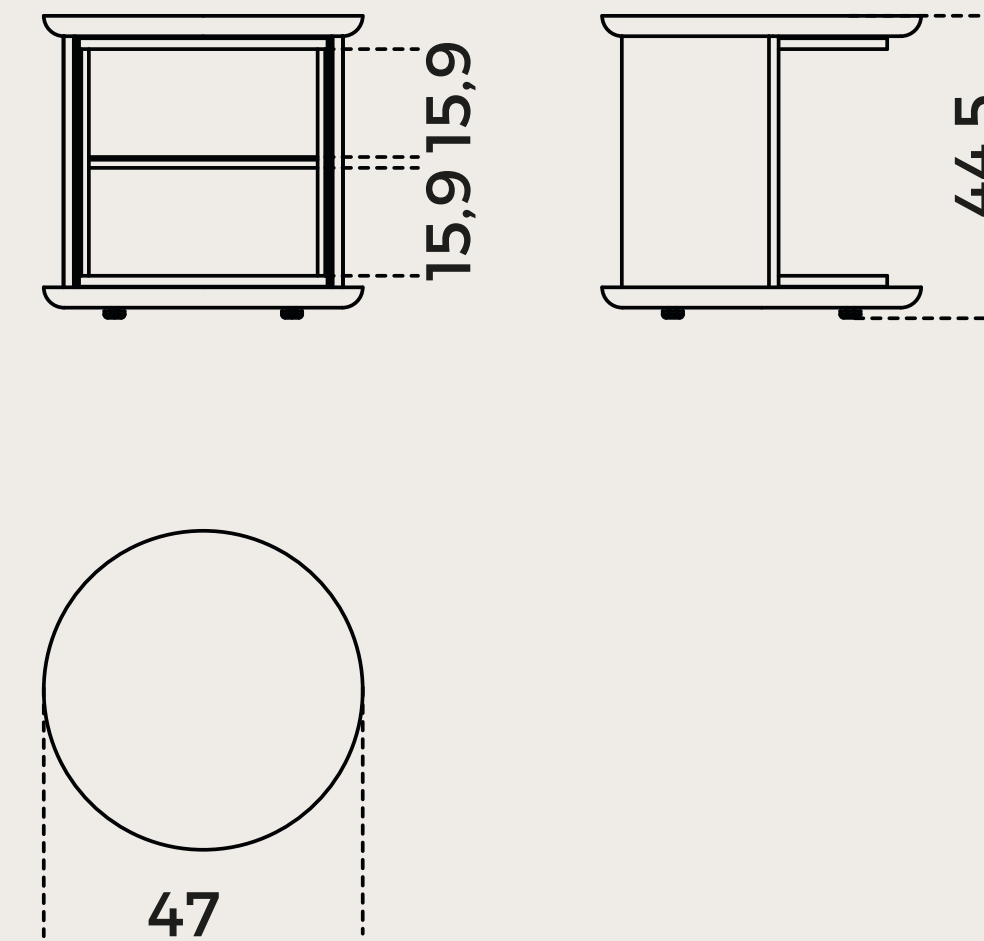

# Sensei desk

DESIGN TOLLGARD + CASTELLANI



SENSEI DESK | TOLLGARD + CASTELLANI



# Sensei desk

DESIGN TOLLGARD + CASTELLANI

Desk with "deep black" lacquered metal structure and wooden top. Black open pore stained ash shelf and back. Resting on the wooden top, 12mm glass top with half bull-nose grinding in the exclusive finish "Rosso Marte" or painted as per samples in the bright version. Also available with 20mm brushed Ceppo di Gré®, satin Arabescato Orobico Rosso, brushed Bianco Carrara Gioia or satin Dover White. Top available also covered by leather fard as per samples. On request, black open pore stained ash drawer unit with removable metal trays covered by leather fard as per samples.

## DIMENSIONS

Cm	Inches
160 x 75 x 75h	63" x 29¾" x 29¾"h
180 x 75 x 75h	71" x 29¾" x 29¾"h
200 x 75 x 75h	78¾" x 29¾" x 29¾"h

SENSEI DESK | TOLLGARD + CASTELLANI

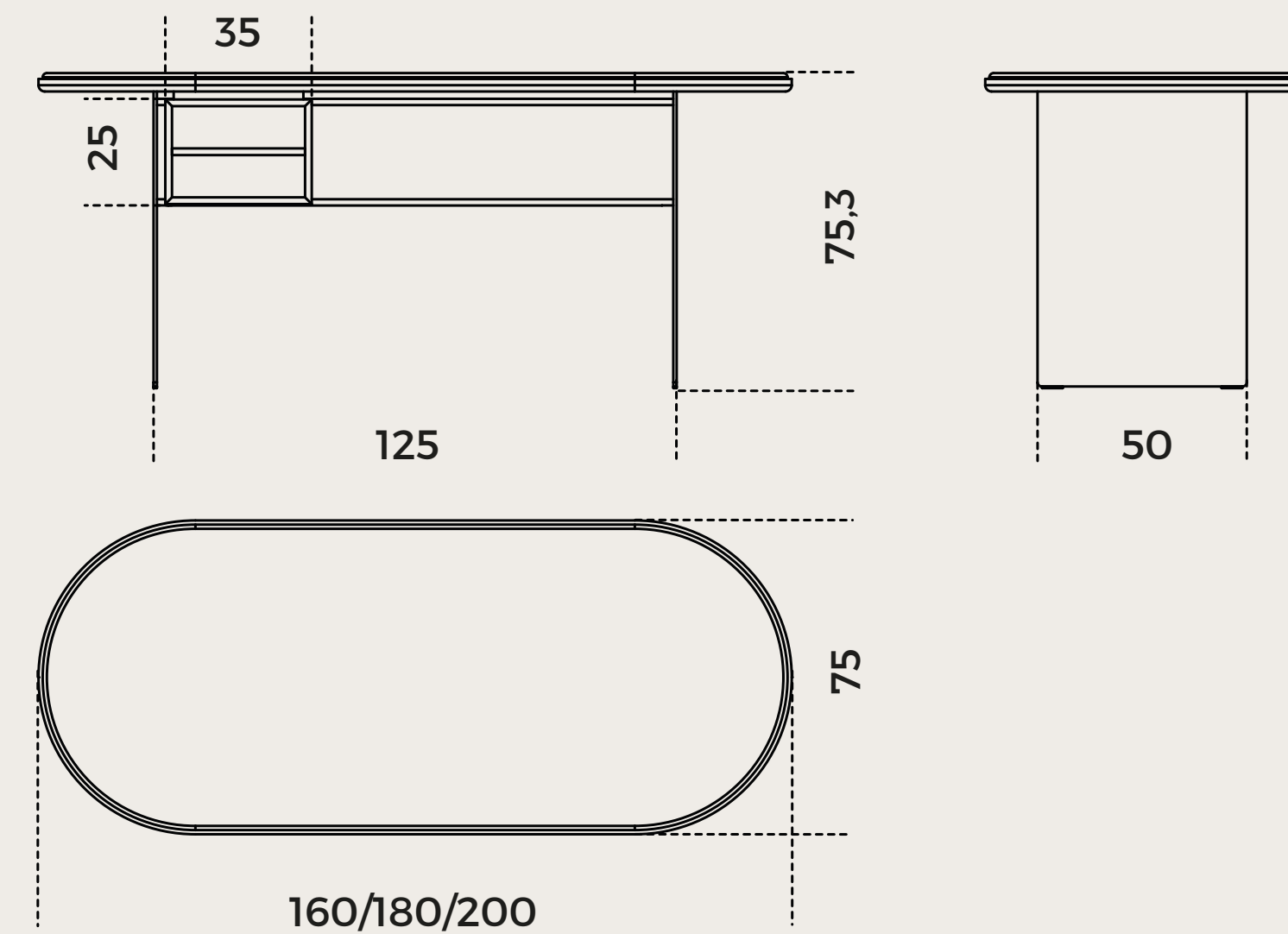

**GLASS TOP:**

EXCLUSIVE ARTISANAL FINISH 'ROSSO MARTE'  
BACKPAINTED GLOSSY GLASS, IN ALL COLOURS OF THE COLLECTION



**MARBLE TOP:**

BRUSHED CEPPPO DI GRÉ  
SATIN ARABESCATO OROBICO ROSSO  
BRUSHED BIANCO CARRARA GIOIA  
SATIN DOVER WHITE

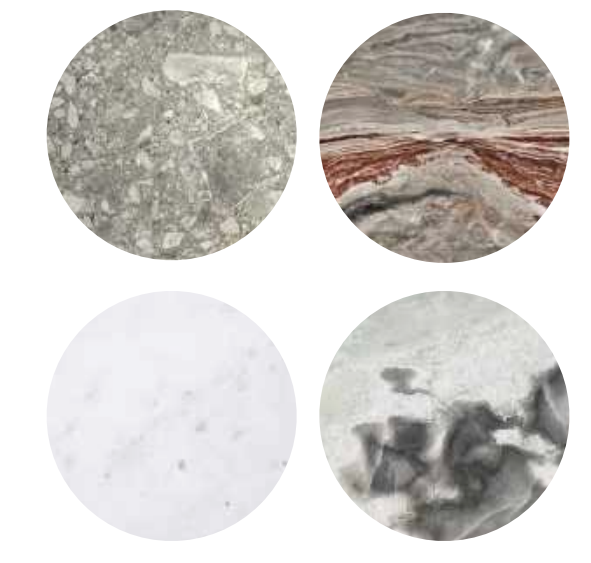

**FARD LEATHER TOP:**



ON REQUEST BLACK OPEN PORE STAINED ASH  
DRAWER UNIT WITH REMOVABLE METAL TRAYS COVERED BY LEATHER FARD AS PER COLLECTION



**STRUCTURE:**

WOOD AND METAL LACQUERED IN THE 'DEEP BLACK' COLOUR

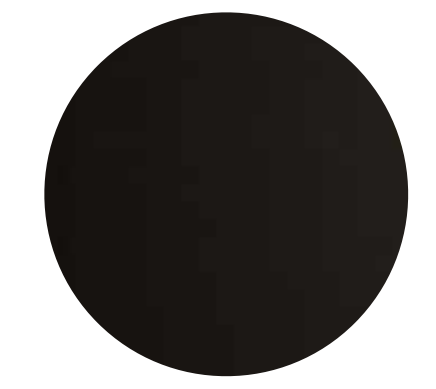

**BACK PANEL:**

BLACK OPEN PORE ASH



# Kumi Comò Kumi Credenza

DESIGN CARLO COLOMBO



KUMI COMÒ E CREDENZA | CARLO COLOMBO

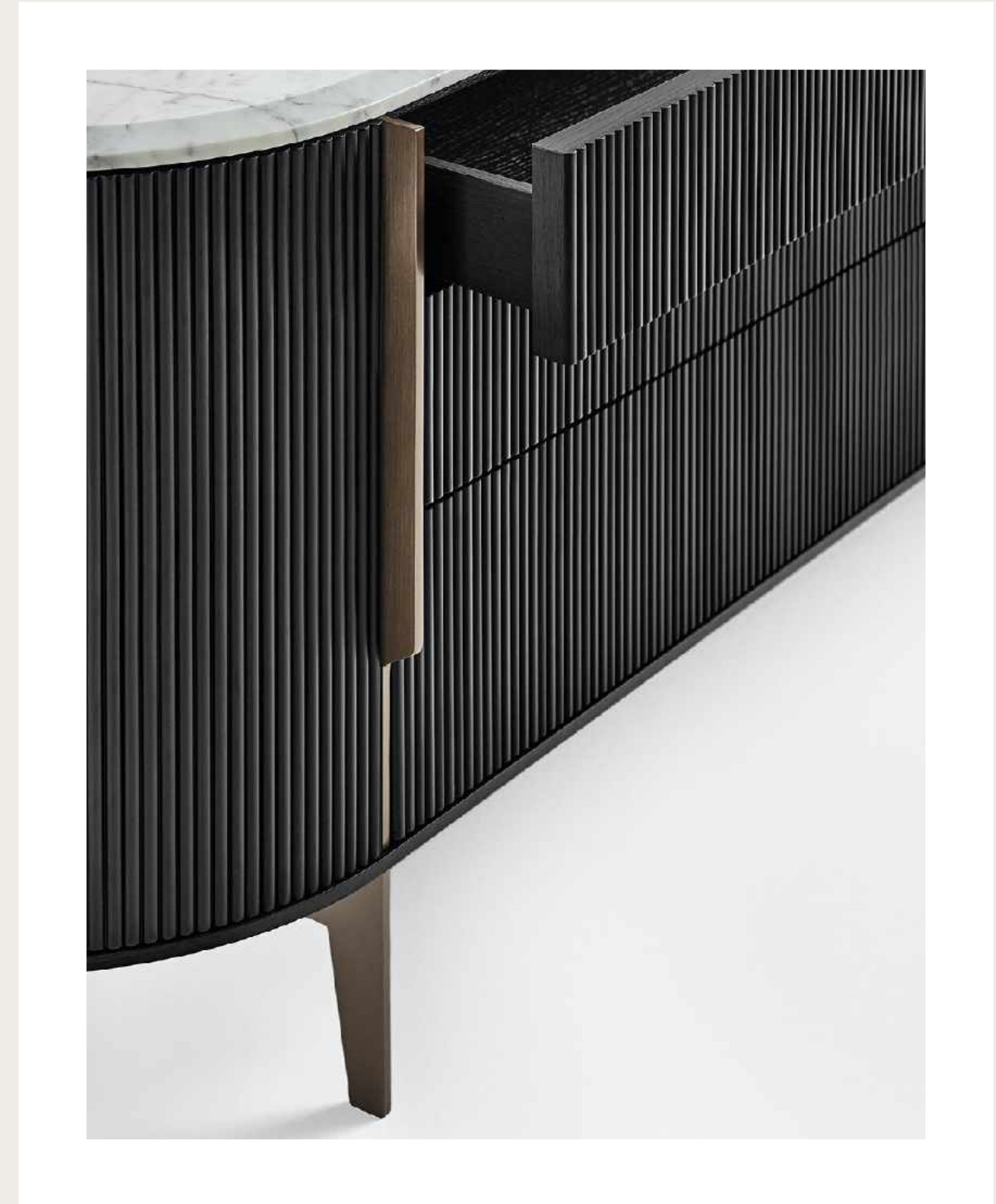

# Kumi Comò Kumi Credenza





DESIGN CARLO COLOMBO

Structure in black open pore stained wood. Fronts and sides clad with hand-knurled border. Lateral doors supplied with inside wooden shelf. Top available in bevelled natural polished Calacatta Vagli Oro, Verde Alpi, satin Arabescato Orobico Rosso, **satin Dover White marble** or 6mm tempered bright black painted glass. Handles and metal parts lacquered in the "fango" colour.

## DIMENSIONS

Cm	Inches
143 x 50 x 75h	56½" x 19¾" x 29¾"h
194 x 50 x 75h	76½" x 19¾" x 29¾"h

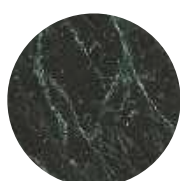
## FINISHES

FINISHES		FINISHES TOP		
ZIGRINATO A MANO		MARBLE	MERBLE	MERBLE
				
OPEN-PORE DYED		DOVER WHITE	ARABESCATO OROBICO ROSSO	VERDE ALPI
		MARBLE	BACK PAINTED CRYSTAL	
				
		CALACATTA VAGLI ORO	BRIGHT BLACK	

KUMI COMÒ E CREDENZA | CARLO COLOMBO



NEW FINISH TOP  
DOVER WHITE MARBLE



2024 COLLECTION

# DINING 2

SALONE DEL  
MOBILE.MILANO  
2024







*DINING 2*

# Re — verre table

DESIGN FEDERICA BIASI



RE-VERRE TABLE | FEDERICA BIASI



# Re — verre table

DESIGN FEDERICA BIASI

Table in recycled glass in "sable" beige or "roche" grey colours.  
Since this is an artisanal and manual process, the measurements are indicative and the surface may be porous and not completely flat.

## DIMENSIONS

Cm	Inches
Ø180 x 73h	Ø71 x 28¾
Ø200 x 73h	Ø78¾ x 28¾

## FINISHES



BEIGE "SABLE"



GREY "ROCHE"

RE-VERRE TABLE | FEDERICA BIASI

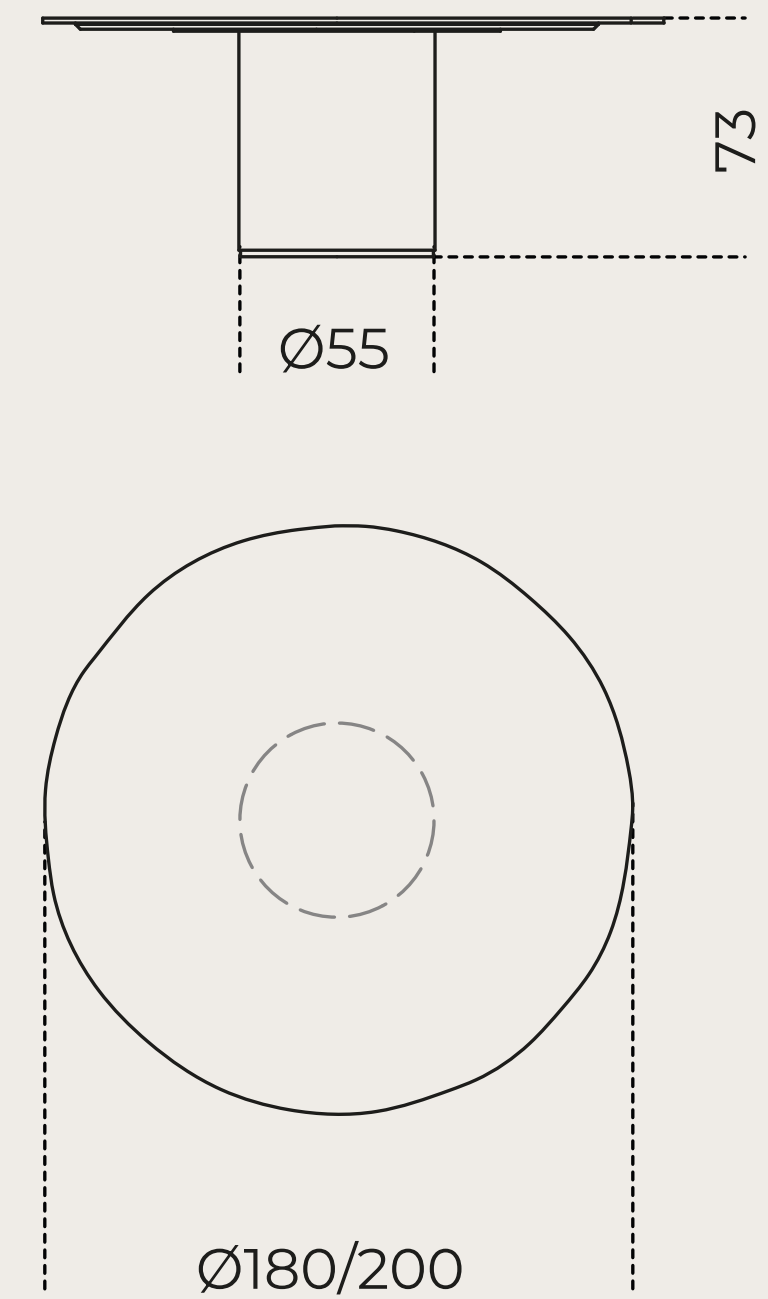

*Single-material recycled glass table in beige "sable" or grey "roche" colors.*

*Since this is handmade and handcrafted, measurements are approximate and the surface may be porous and may not be completely planar.*

**"ROCHE" GREY RECYCLED GLASS**



**BEIGE "SABLE" RECYCLED GLASS**

# Hide&Seek Door

DESIGN PIETRO RUSSO



HIDE&SEEK DOOR | PIETRO RUSSO





HIDE&SEEK DOOR | PIETRO RUSSO



# Hide&Seek Door



## DESIGN PIETRO RUSSO

Sideboard with structure, shelves, doors and rotating half-cylinder in glossy or opaque lacquered wood. Available colours: "Rosso Persia", "Grigio Londra", "Nero Giza", "Bianco Camargue", "Verde Provenza", "Blu Pacifico", "Bordeaux Etruria", "Rosa Jaipur" or "Sabbia del Nilo". Satin brass details. Unit with push and pull door with wooden lacquered shelf in the same finish. On request version with double-sided door opening.

### DIMENSIONS

Cm	Inches
200 x 50 x 76h	78¾ x 19¾" x 30"h
250 x 50 x 76h	98½" x 19¾" x 30"h

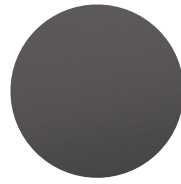
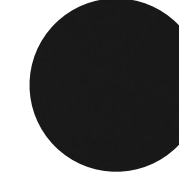
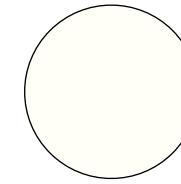
### FINISHES OF THE STRUCTURE

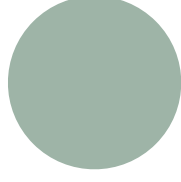
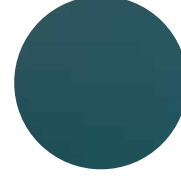
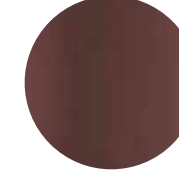
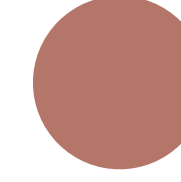
LACQUERED  ROSSO PERSIA	LACQUERED  GRIGIO LONDRA	LACQUERED  NERO GIZA	LACQUERED  BIANCO CAMARGUE	LACQUERED  SABBIA DEL NILO
LACQUERED  VERDE PROVENZA	LACQUERED  BLU PACIFICO	LACQUERED  BORDEAUX ETRURIA	LACQUERED  ROSA JAIPUR	

## HIDE&SEEK DOOR | PIETRO RUSSO

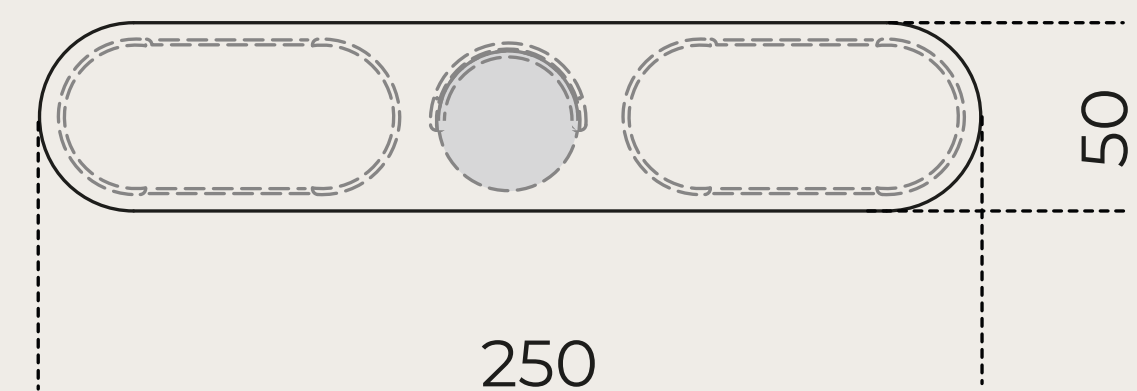
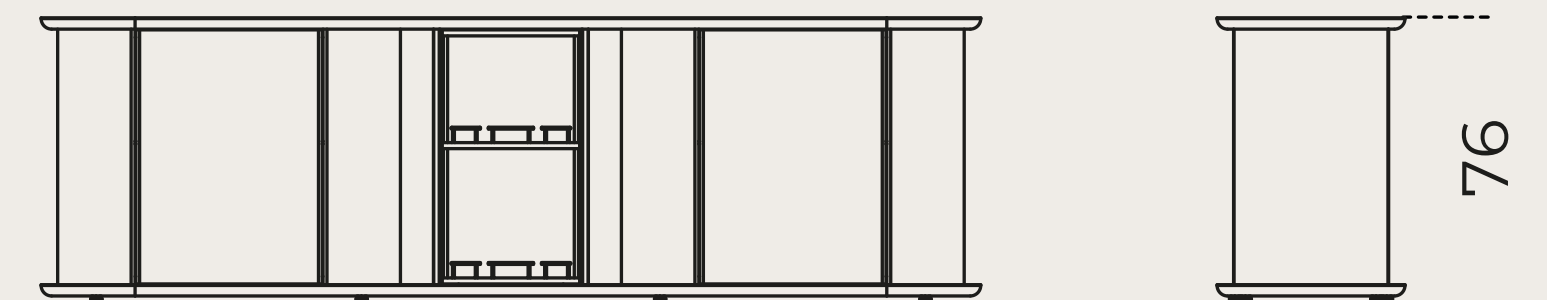
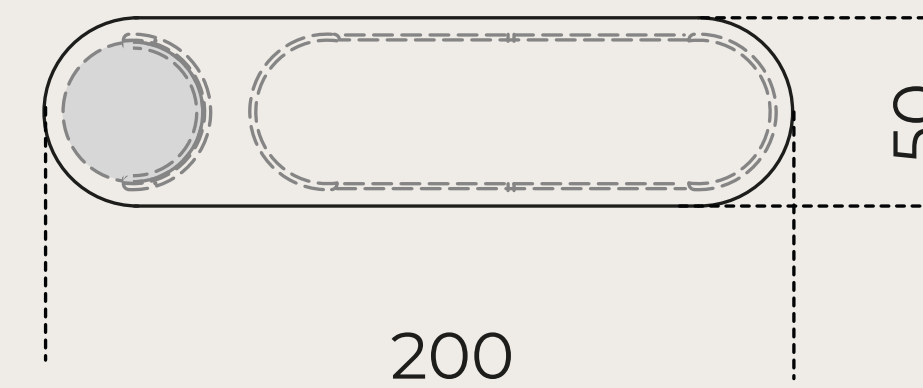
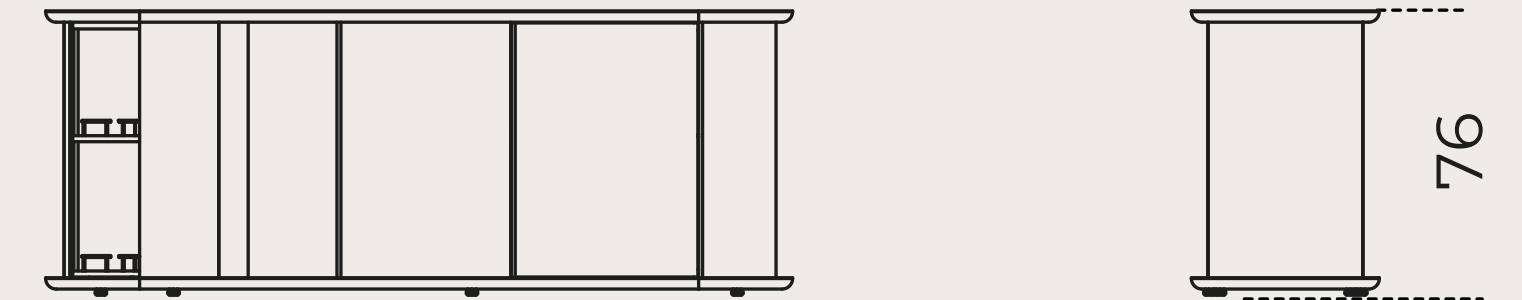

2024 COLLECTION

# LIVING 3

SALONE DEL  
MOBILE.MILANO  
2024







# Soda

DESIGN DRAGA & AUREL



SODA | DRAGA & AUREL

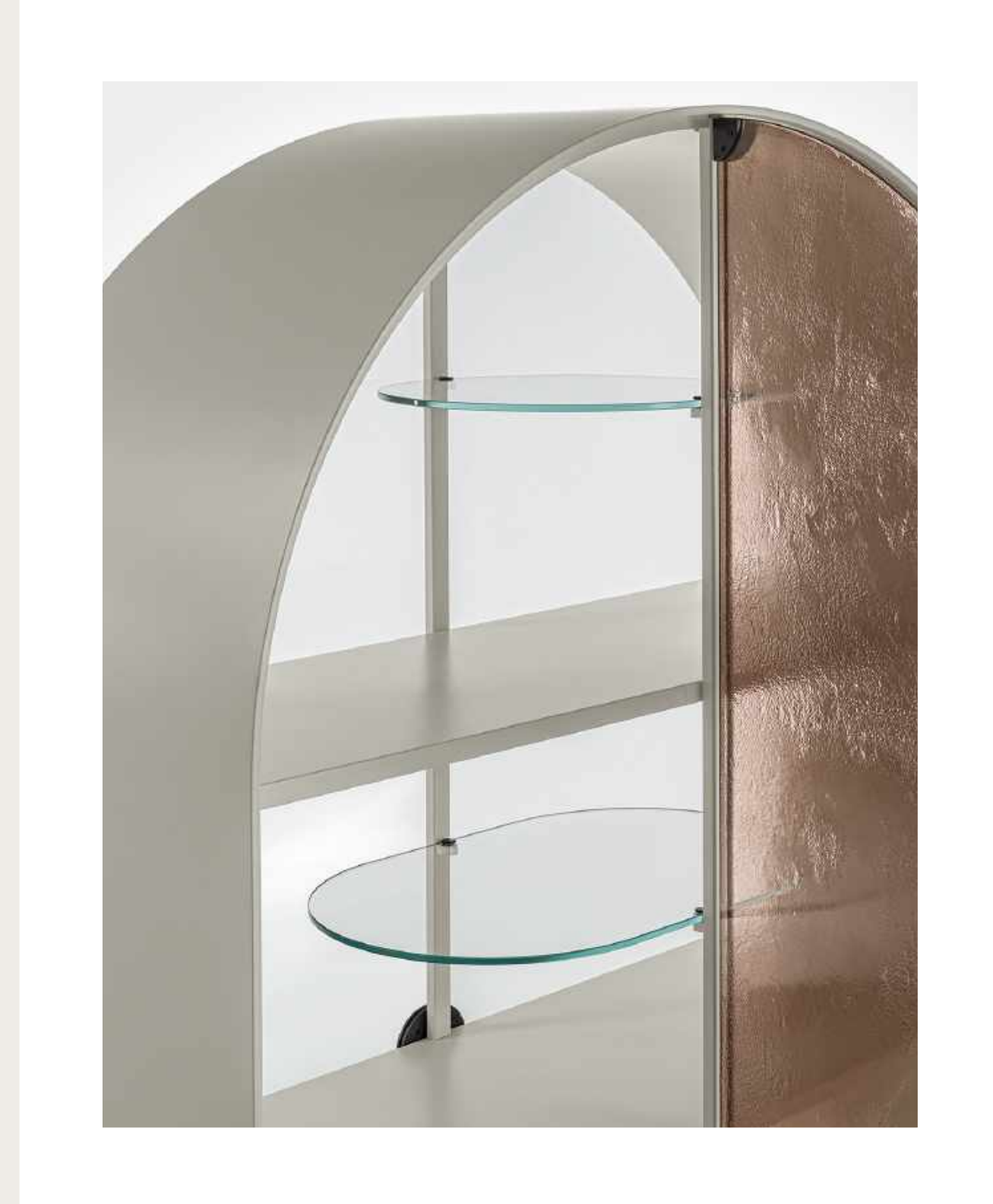

# Soda

DESIGN DRAGA & AUREL

Sideboard with "elephant grey" lacquered wooden structure and 6mm molten tempered glass amber color lacquered door. Also available version with black open pore stained ash structure and 6mm molten tempered glass "grigio Italia" door. Both version with back and shelves in 6mm tempered smoked "grigio Italia" glass. Details in satin brass.

Available also new version with "Sabbia del Nilo" opaque lacquered wooden structure and 6mm molten tempered amethyst color lacquered glass door. Available also with 6mm molten tempered extralight glass door. Back and shelves in 6mm tempered extralight glass. On request 6mm molten tempered amethyst color lacquered glass back. Patinated bronze metal details.

## DIMENSIONS

Cm	Inches
120 x 46 x 165h	47¼" x 18¼" x 65"h

SODA | DRAGA & AUREL

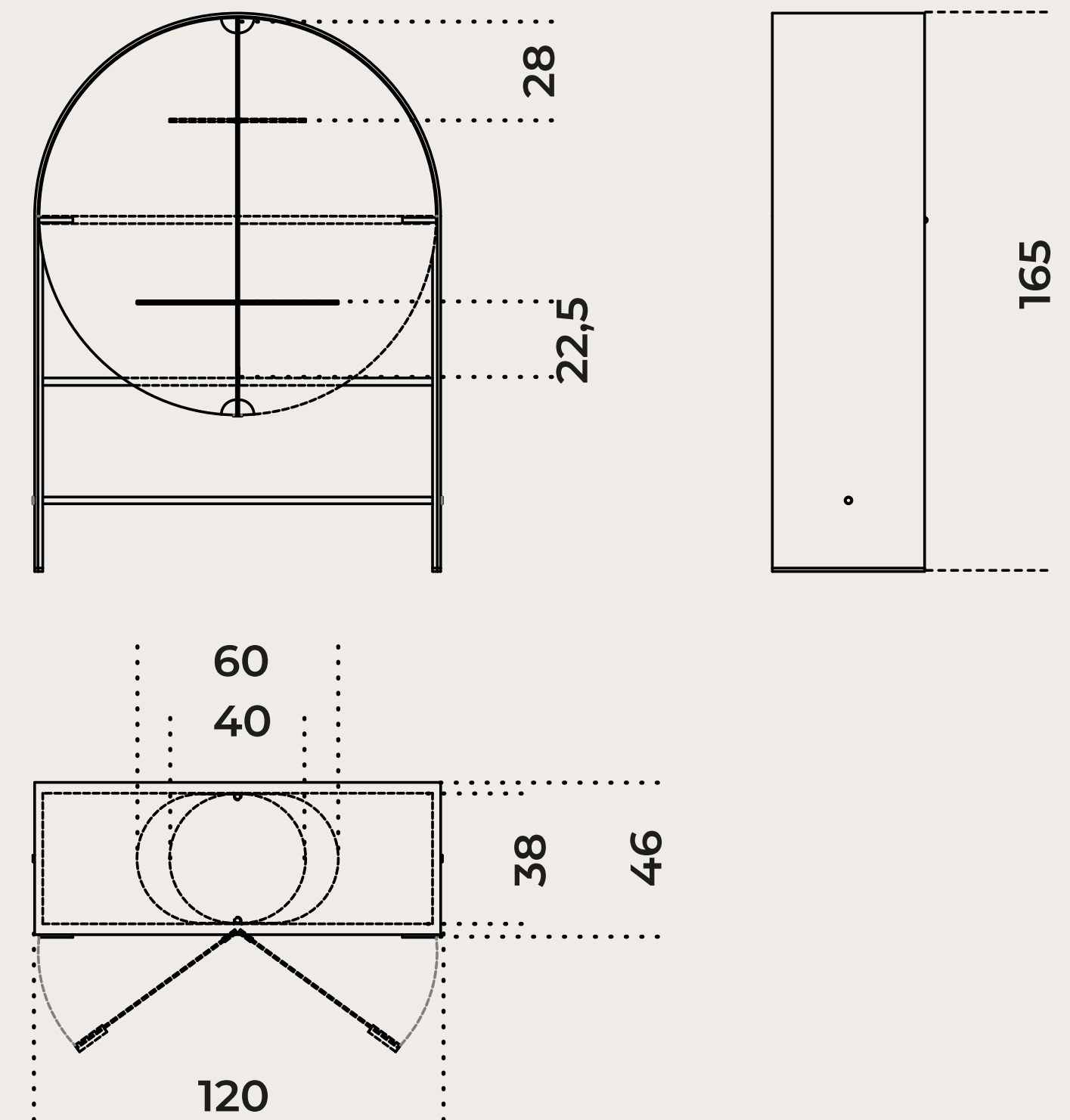

# Soda

DESIGN DRAGA & AUREL

## FINISHES OPTIONS

STRUCTURE



Black open pore stained ash



Lacquered 'elephant grey'

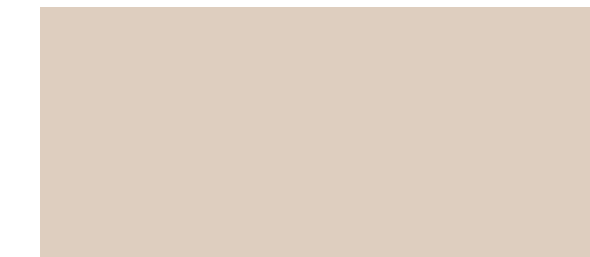

Opaque lacquered 'Sabbia del Nilo'

DOORS



'Grigio italia' molten glass

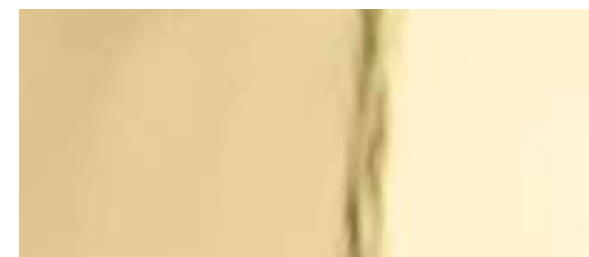

Molten glass lacquered in the amber color



Molten glass lacquered in the amethyst color

BACKPANEL AND SHELVES

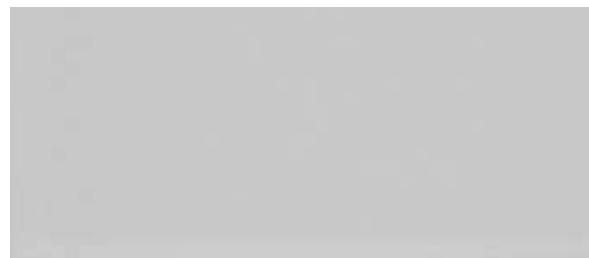

'Grigio Italia' Glass

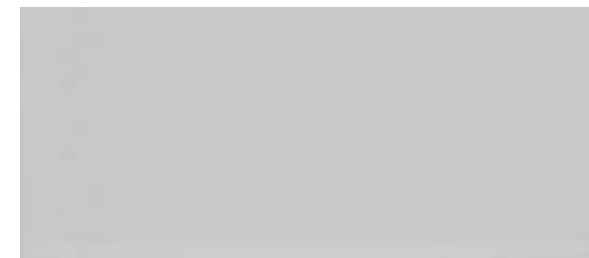

'Grigio Italia' Glass

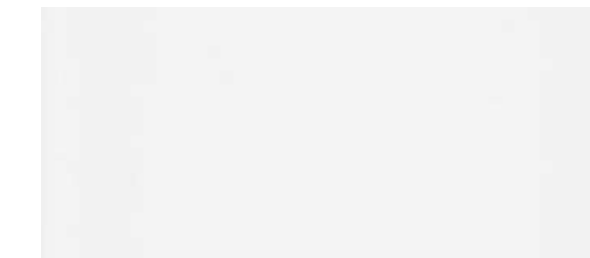

Extralight Glass

DETAILS



Satin brass



Satin brass

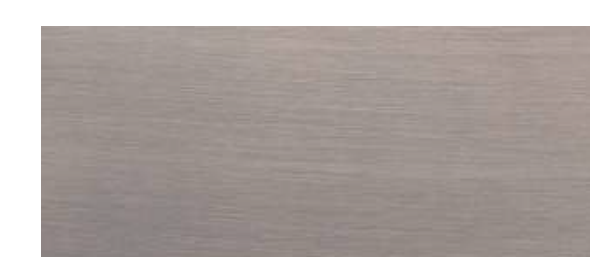

Patinated bronze

## NEW VERSION

# Lilas Mosaïque

DESIGN DAINELLI STUDIO



LILAS MOSAÏQUE | DAINELLI STUDIO





LILAS MOSAIQUE | DAINELLI STUDIO



# Lilas Mosaique

DESIGN DAINELLI STUDIO

Modular seating system in non-deformable polyurethane foam in different density and polyester fibre. Black lacquered metal base plate. Available with removable cover in fabric or leather as per samples. Ballasted backrest available on request. The backrests can be positioned as preferred and can be accompanied by 55x55cm cushion to make the seat more comfortable. Fango lacquered metal side table on request.

Additional stitching is required for elements with leather upholstery compared to elements with fabric upholstery.

**DIMENSIONS**

**SEATS**

Cm	Inches	NEW MODULES	
95 x 95 x 40	37½ x 37½ x 15¾	95 x 95 x 40	37½ x 37½ x 15¾
143 x 143 x 40	56½ x 56½ x 15¾	143 x 143 x 40	56½ x 56½ x 15¾
190 x 95 x 40	75 x 37½ x 15¾	143 x 100 x 40	56½ x 39½ x 15¾
275 x 95 x 40	108½ x 37½ x 15¾		

**SIDETABLES**

Cm	Inches
50 x 25 x 22	19¾ x 10 x 8¾
50 x 35 x 22	19¾ x 14 x 8¾

**BACKREST AND PILLOWS**

Cm	Inches	Cm	Inches
Backrest		Backrest	
80 x 26 x 30		31½ x 10¼ x 12	
Backrest cushion		Backrest cushion	
55 x 8 x 55		21¾ x 3¼ x 21¾	

LILAS MOSAIQUE | DAINELLI STUDIO

**SEATING SYSTEM**

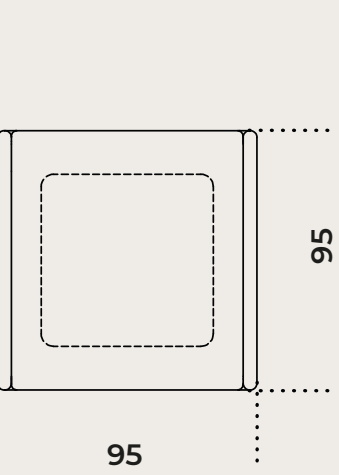

**MODULE**  
95x95x40h

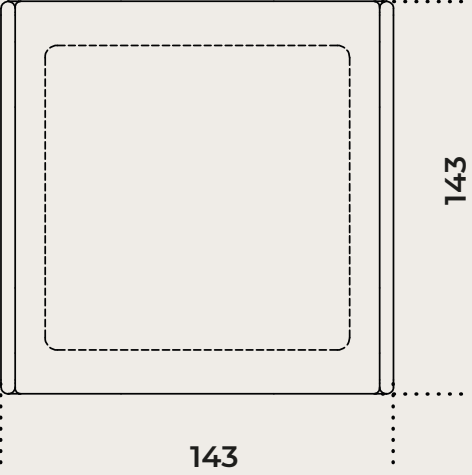

**MODULE**  
143x143x40h

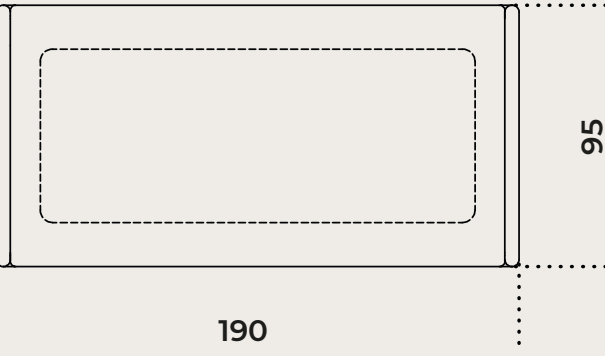

**MODULE**  
190x95x40h

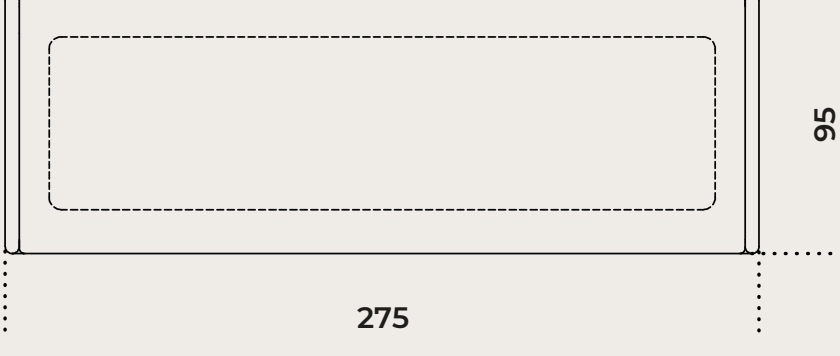

**MODULE**  
275x95x40h

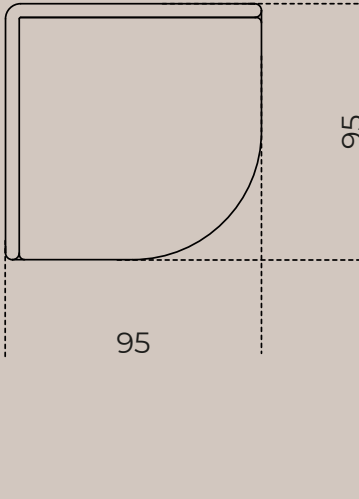

**MODULE**  
95x95x40h

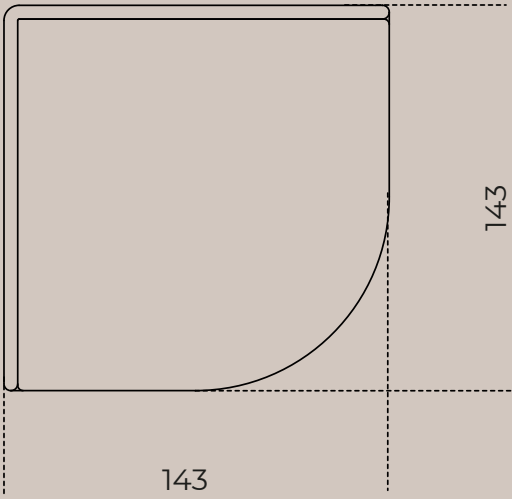

**MODULE**  
143x143x40h

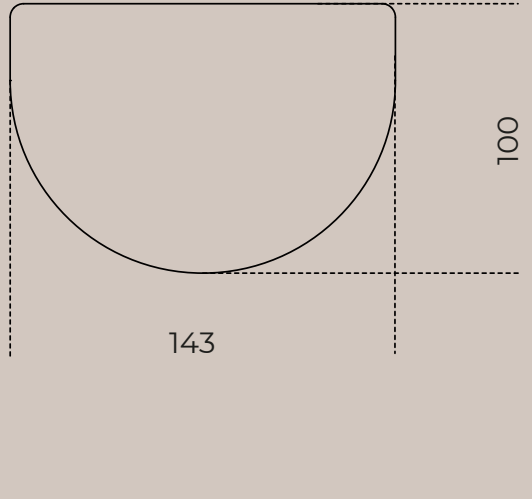

**MODULE**  
143x100x40h

## EXAMPLES OF COMPOSITIONS

### COMPOSITION 1

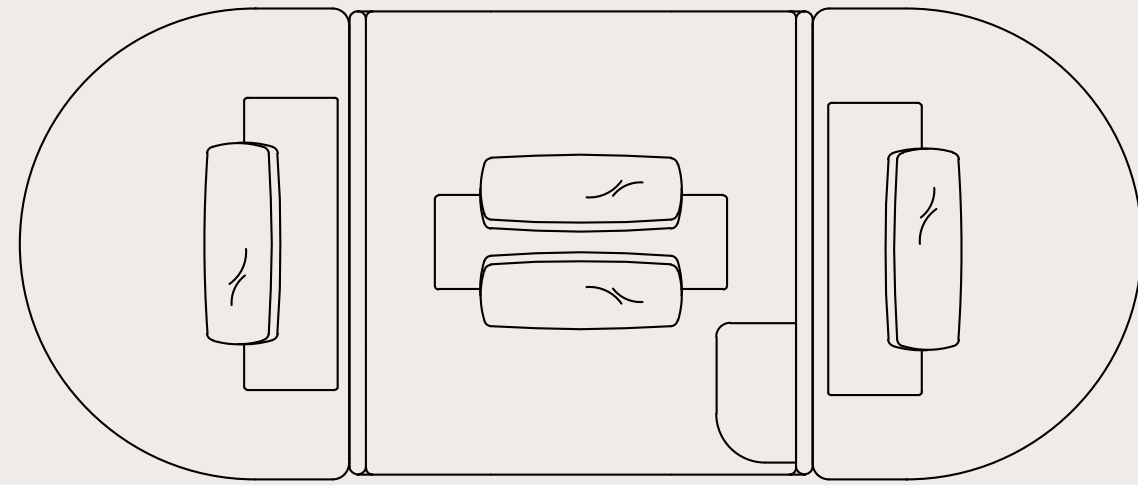

- n.1 MODULE 143x143x40h
- n.2 MODULES 143x100x40h
- +
- n.3 BACKRESTS 80x26x30h
- n.4 CUSHIONS 55x8x55h
- +
- n.1 SIDETABLE 50x25x22h

### COMPOSITION 2

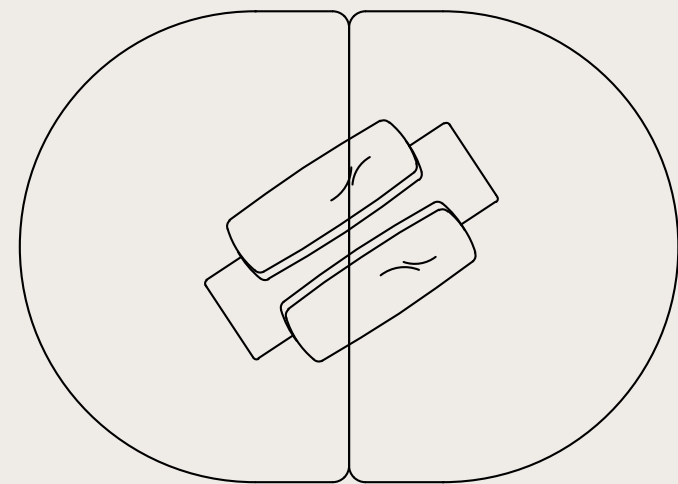

- n.2 MODULES 143x100x40h
- +
- n.1 BACKREST 80x26x30h
- n.2 CUSHIONS 55x8x55h

### COMPOSITION 3

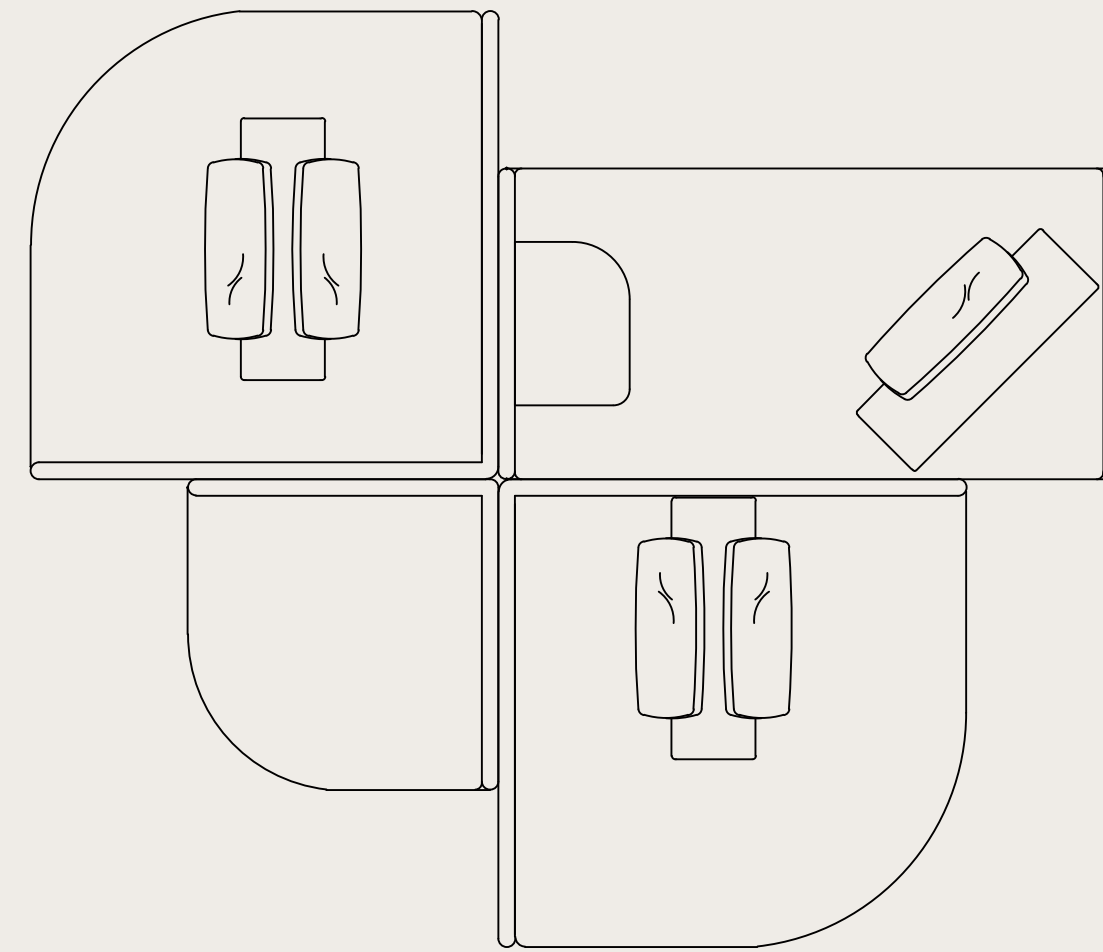

- n.1 MODULE 95x95x40h
- n.1 MODULE 190x95x40h
- n.2 MODULES 143x143x40h
- +
- n.3 BACKRESTS 80x26x30h
- n.5 CUSHIONS 55x8x55h
- +
- n.1 SIDETABLE 50x35x22h

### COMPOSITION 4

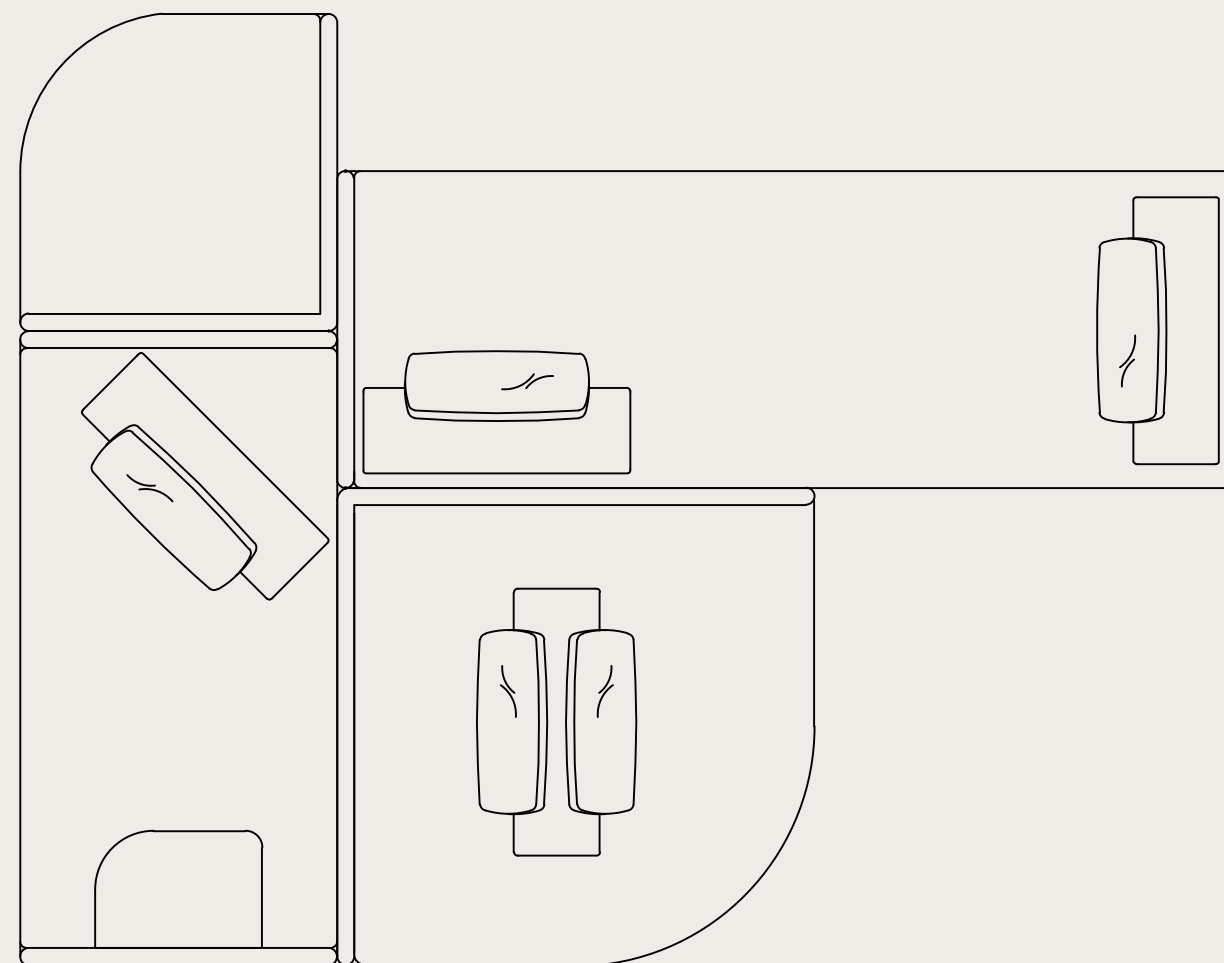

- n.1 MODULE 95x95x40h
- n.1 MODULE 275x95x40h
- n.1 MODULE 143x143x40h
- n.1 MODULE 190x95x40h
- +
- n.4 BACKRESTS 80x26x30h
- n.5 CUSHIONS 55x8x55h
- +
- n.1 SIDETABLE 50x35x22h



2024 COLLECTION

# DINING 3

SALONE DEL  
MOBILE.MILANO  
2024





*DINING 3*

# Selce — T

DESIGN STUDIOPEPE

SELCE-T | STUDIOPEPE

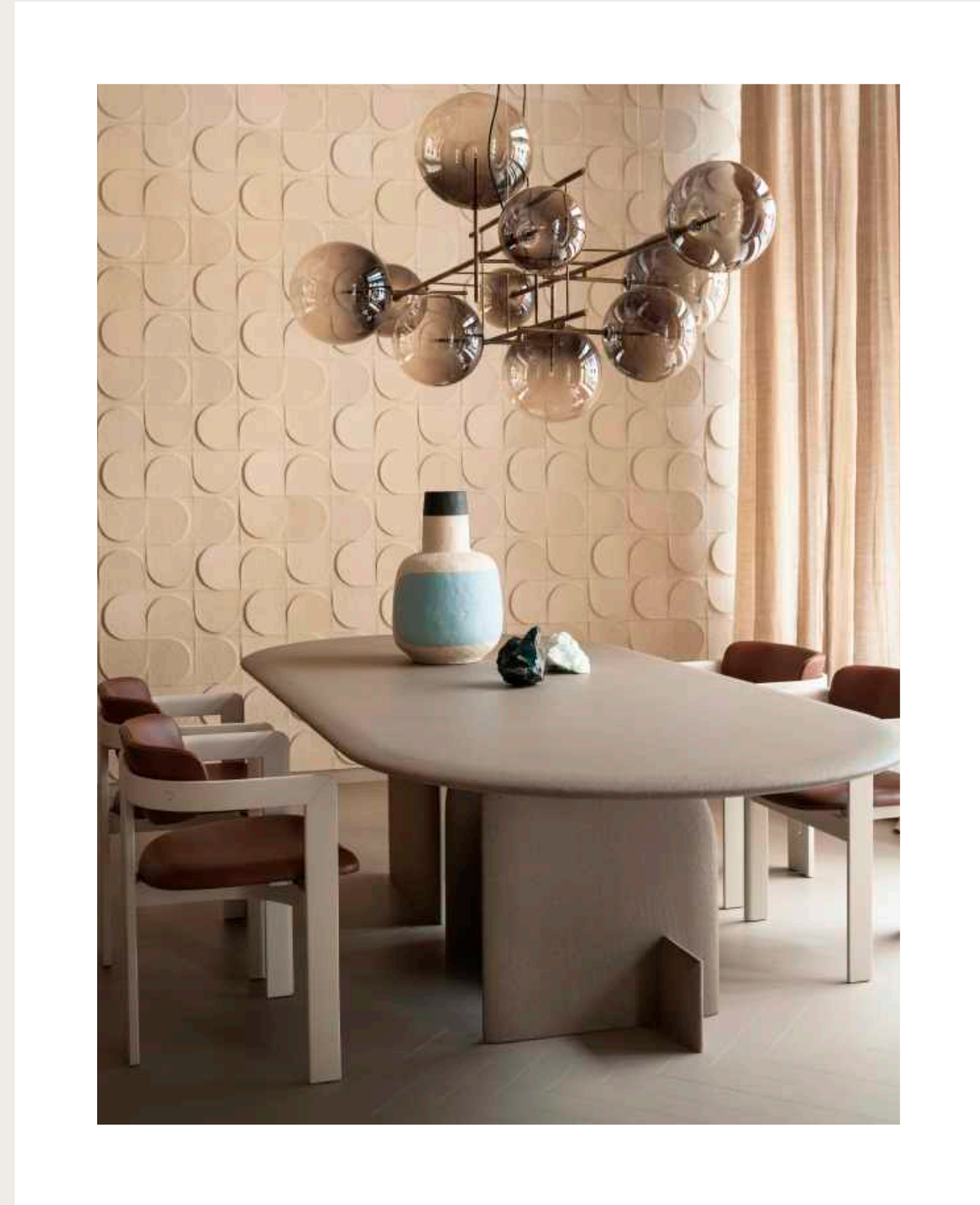

# Selce — T

DESIGN STUDIOPEPE

Table made by applying natural stone powder through a manual spatula technique.  
 Available in "bruciato" and "crema" colors.  
 Since it is a mixture of pulverized natural stones, uniformity in the color shades is not guaranteed.

## DIMENSIONS

Cm	Inches
Ø130 x 74,5h	Ø51¼" x 29½"h
Ø150 x 74,5h	Ø59¼" x 29½"h
220 x 120 x 74,5h	86¾" x 47¼" x 29½"h
240 x 120 x 74,5h	94½" x 47¼" x 29½"h
280 x 130 x 74,5h	110¼" x 51¼" x 29½"h
300 x 130 x 74,5h	118¼" x 51¼" x 29½"h

## FINISHES



CREMA



BRUCIATO

SELCE-T | STUDIOPEPE

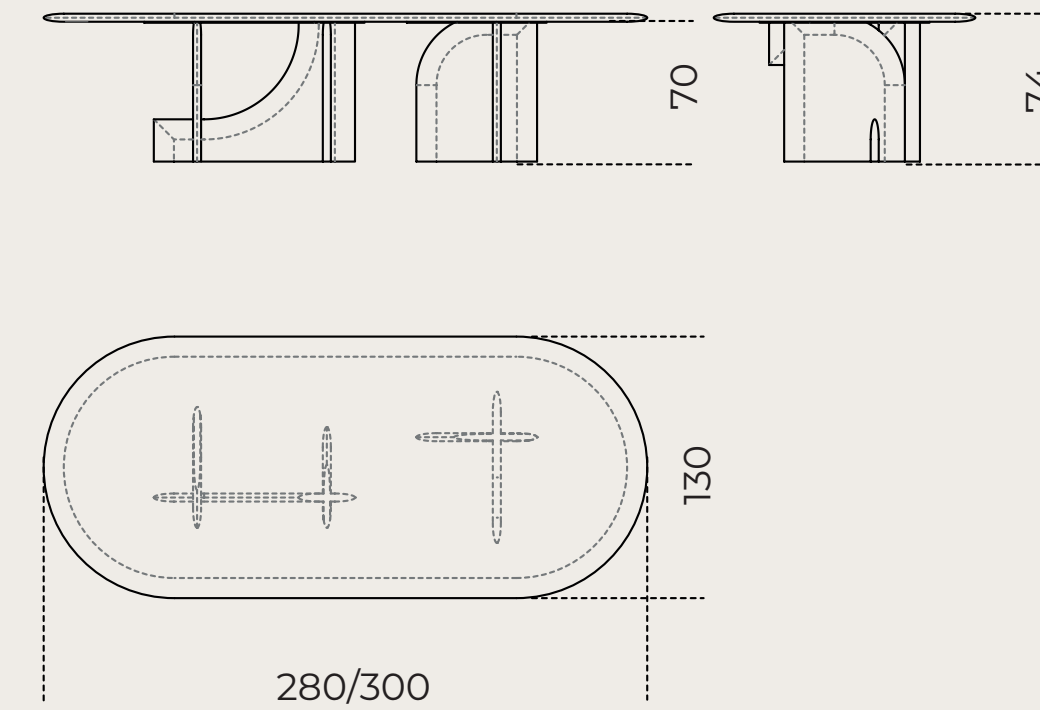
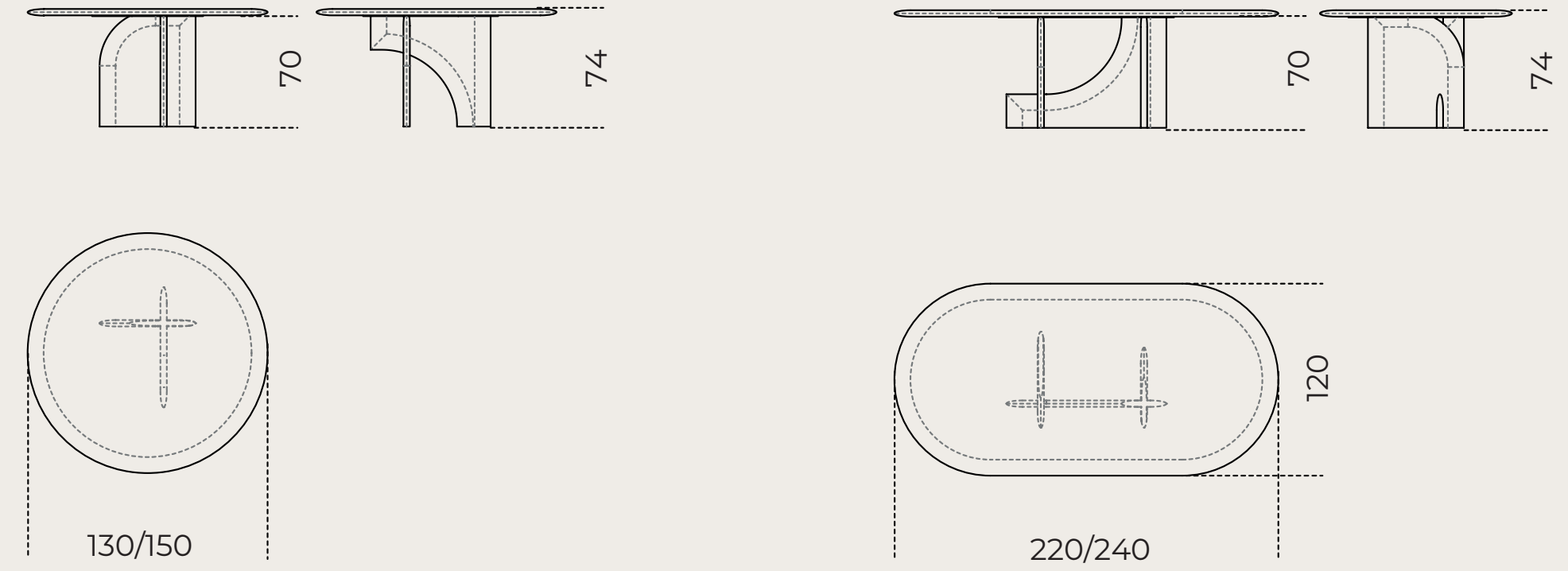

Table made by applying **natural stone powder** through a **hand troweling technique**.

Available in "crema" and "bruciato" colors.

"Burnt" - Bruciato - mixture made with natural earthenware powder and colored cement.

"Cream" - Crema - impasto made with Carrara marble powder and colored cement.

The top finish is water-based acrylic clearcoat so as to provide more protection and durability.

Since this is a mixture of pulverized natural stones, uniformity in color shades is not guaranteed.

**"CREMA"** COLOR FINISH



**"BRUCIATO"** COLOR FINISH

# H2O

DESIGN STUDIOPEPE



H2O | STUDIOPEPE



# H2O

## DESIGN STUDIOPEPE

Armchair with metal inside structure padded with non-deformable polyurethane foam in different density. Completely covered by fabric or leather as per samples.

Not removable cover.

The combination of the hinges is defined by Gallotti&Radice by matching it with the chosen covering.

Additional stitching is required for elements with leather upholstery compared to elements with fabric upholstery.

### DIMENSIONS

Cm	Inches
62,5 x 52,3 x 69h	24¾" x 20¾" x 27"h

H2O | STUDIOPEPE

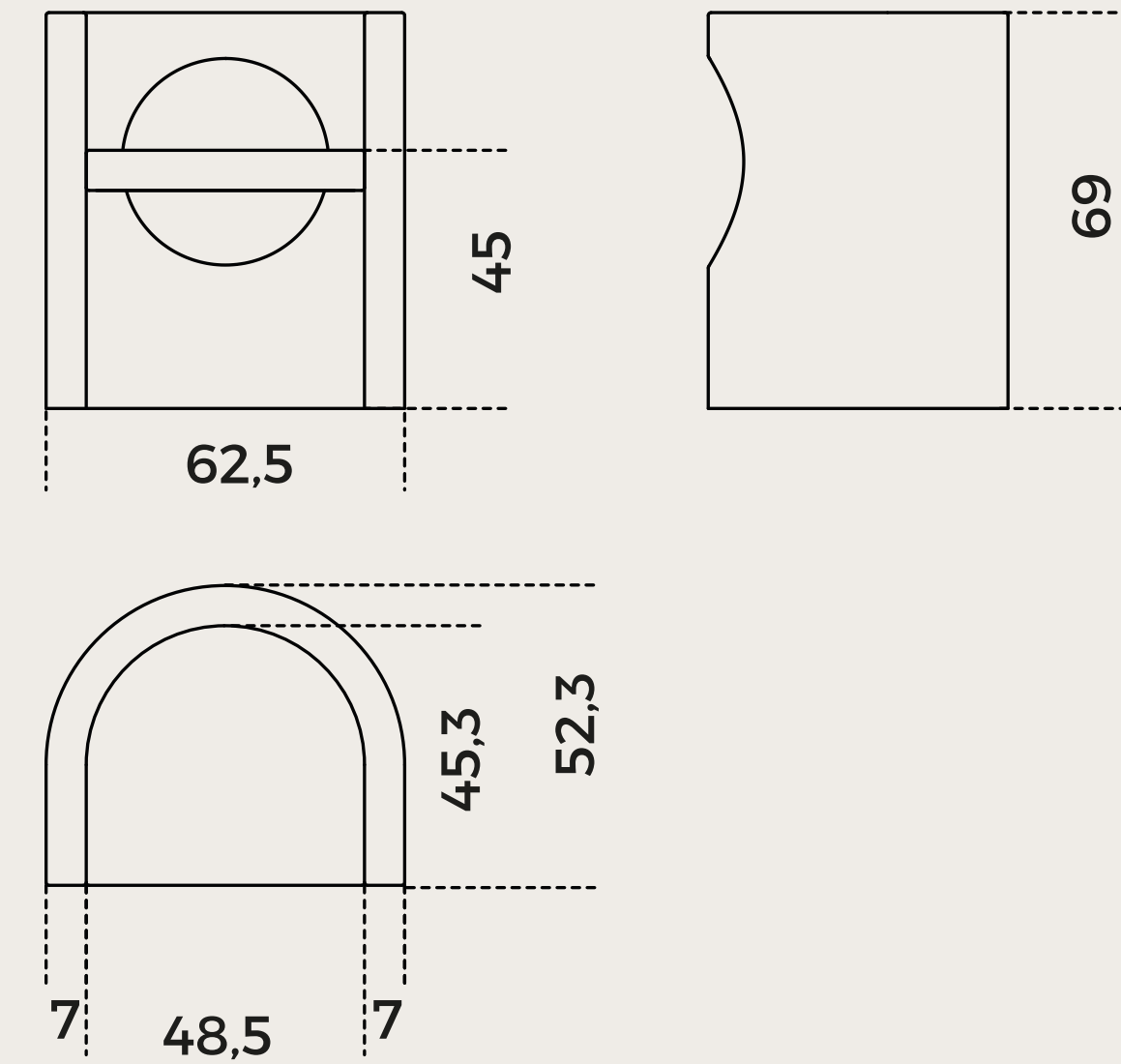

# Gastone

DESIGN CARLO COLOMBO



GASTONE | CARLO COLOMBO





# Gastone / Gastone Low

DESIGN CARLO COLOMBO

Sideboard in glossy or **opaque lacquered wood**. Available colours: "Rosso Persia", "Grigio Londra", "Nero Giza", "Bianco Camargue", "Verde Provenza", "Blu Pacifico", "Bordeaux Etruria", "Rosa Jaipur" or **"Sabbia del Nilo"**. **Internal part in "herringbone grey" colour.**

Top in the same finish as the sideboard.

Available, on request, natural brushed Travertino Romano (not treated with resin) or brushed Ceppo di Cré® top.

Upon request 8mm extralight tempered shaped upper shelf.

The module with doors can be supplied with an extralight glass internal shelf and the module with big drawer can be supplied with an internal drawer.

Available in standard compositions.

## DIMENSIONS

GASTONE		GASTONE LOW	
Cm	Inches	Cm	Inches
205 x 55 x 73,5h	80¾" x 21¾" x 29"h	205 x 55 x 57	80¾" x 21¾" x 22½"
245 x 55 x 73,5h	96½" x 21¾" x 29"h	245 x 55 x 57	96½" x 21¾" x 22½"
		406 x 55 x 57	160 x 21¾" x 22½"
		446 x 55 x 57	175¼" x 21¾" x 22½"
		486 x 55 x 57	191½" x 21¾" x 22½"

Shaped glass shelf  
with supporting vertical panels

200 78¾"  
240 94½"

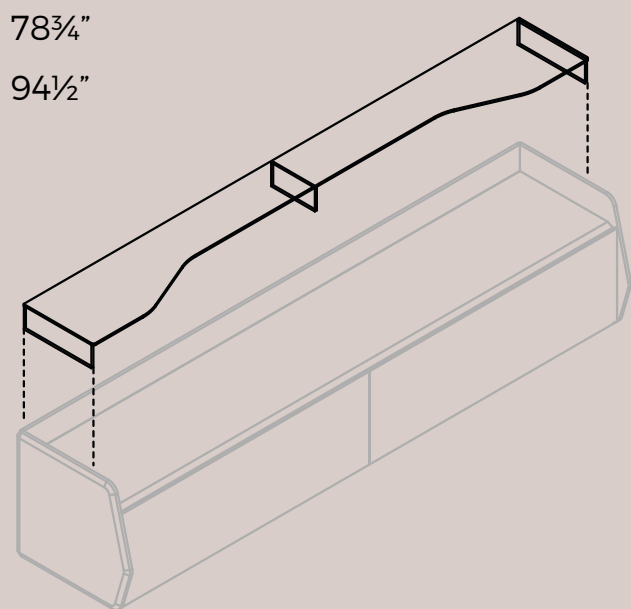

GASTONE | CARLO COLOMBO

## GASTONE

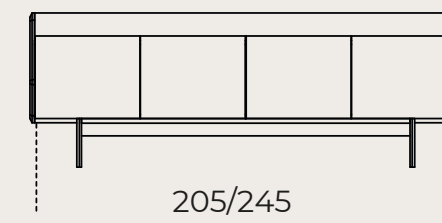

AA

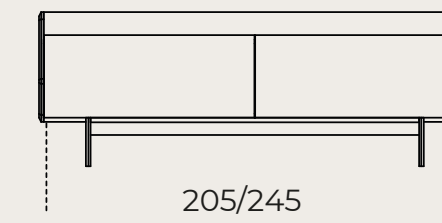

CC

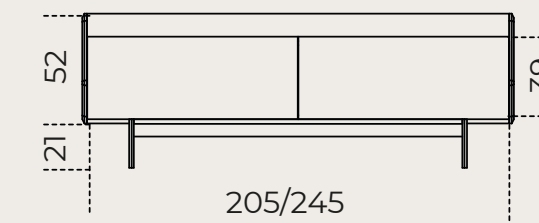

RR

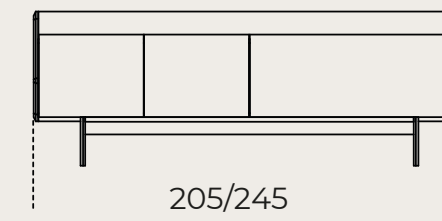

AC

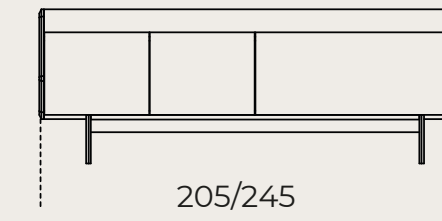

AR

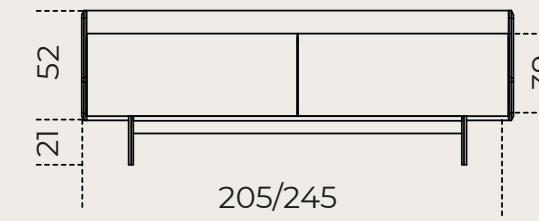

RC

## GASTONE LOW

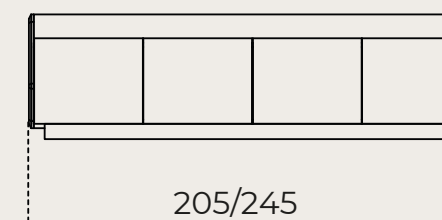

AA

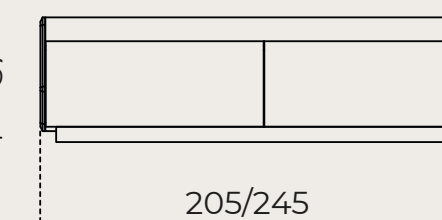

RR

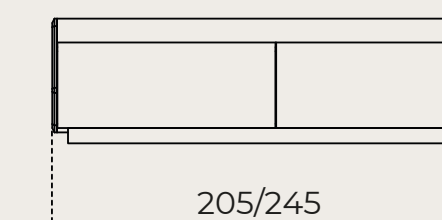

CC

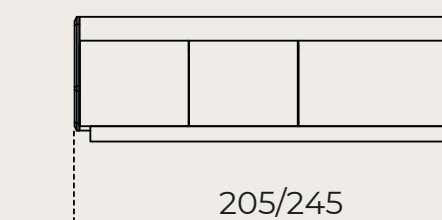

AC

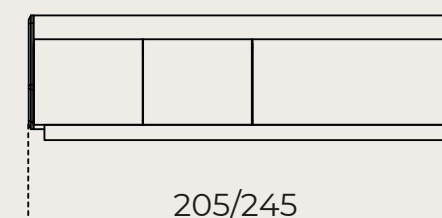

AR

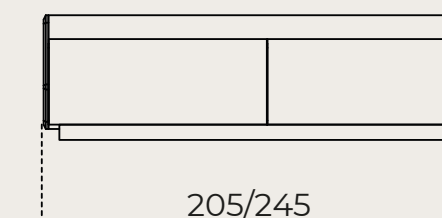

RC

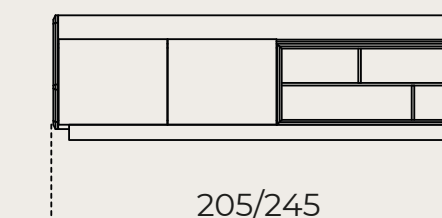

AG

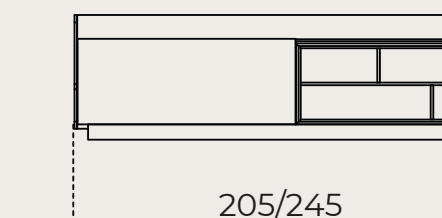

RG

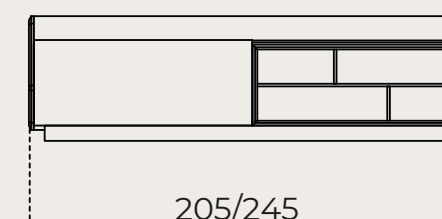

CG

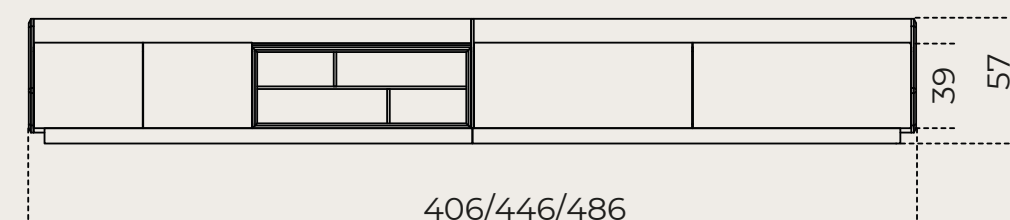

AGRC

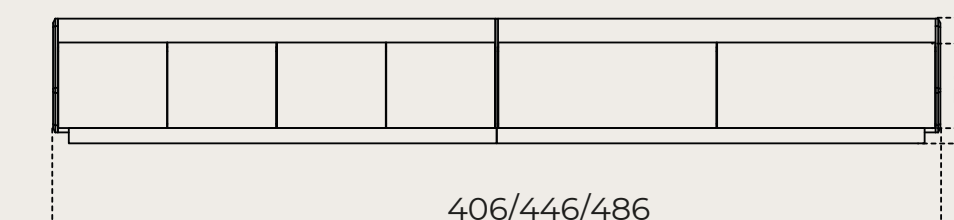

AACC

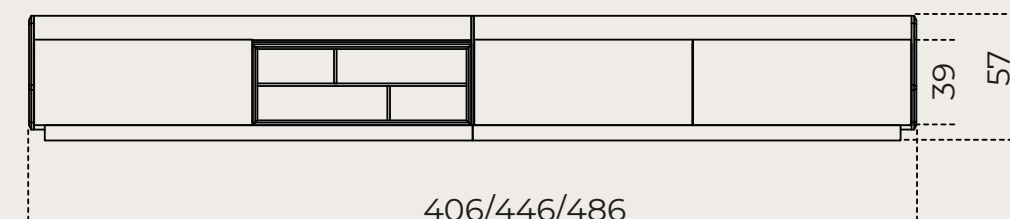

RGCC

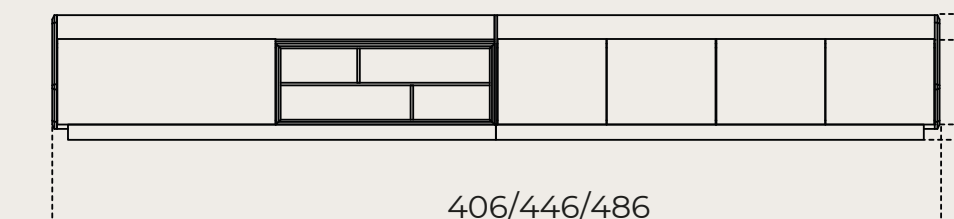

CGAA

# Gastone/ Gastone Low

DESIGN CARLO COLOMBO

GASTONE | CARLO COLOMBO

## INTERIOR FINISH NEW



HERRINGBONE GREY

## EXTERIOR FINISHES

LACQUERED



ROSSO PERSIA

LACQUERED

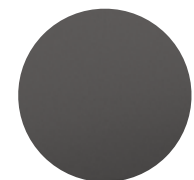

GRIGIO LONDRA

LACQUERED

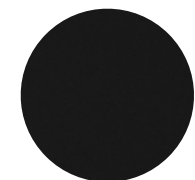

NERO GIZA

LACQUERED

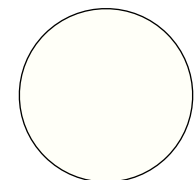

BIANCO CAMARGUE

LACQUERED



SABBIA DEL NILO

LACQUERED

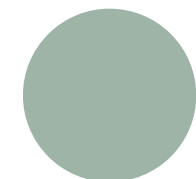

VERDE PROVENZA

LACQUERED

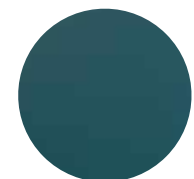

BLU PACIFICO

LACQUERED



BORDEAUX ETRURIA

LACQUERED

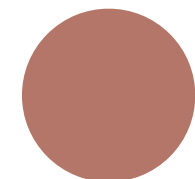

ROSA JAIPUR



NEW LACQUER  
SABBIA DEL NILO

NEW INTERNAL FINISH  
HERRINGBONE GREY

# Iperborea

DESIGN STUDIOPEPE



IPERBOREA | STUDIOPEPE

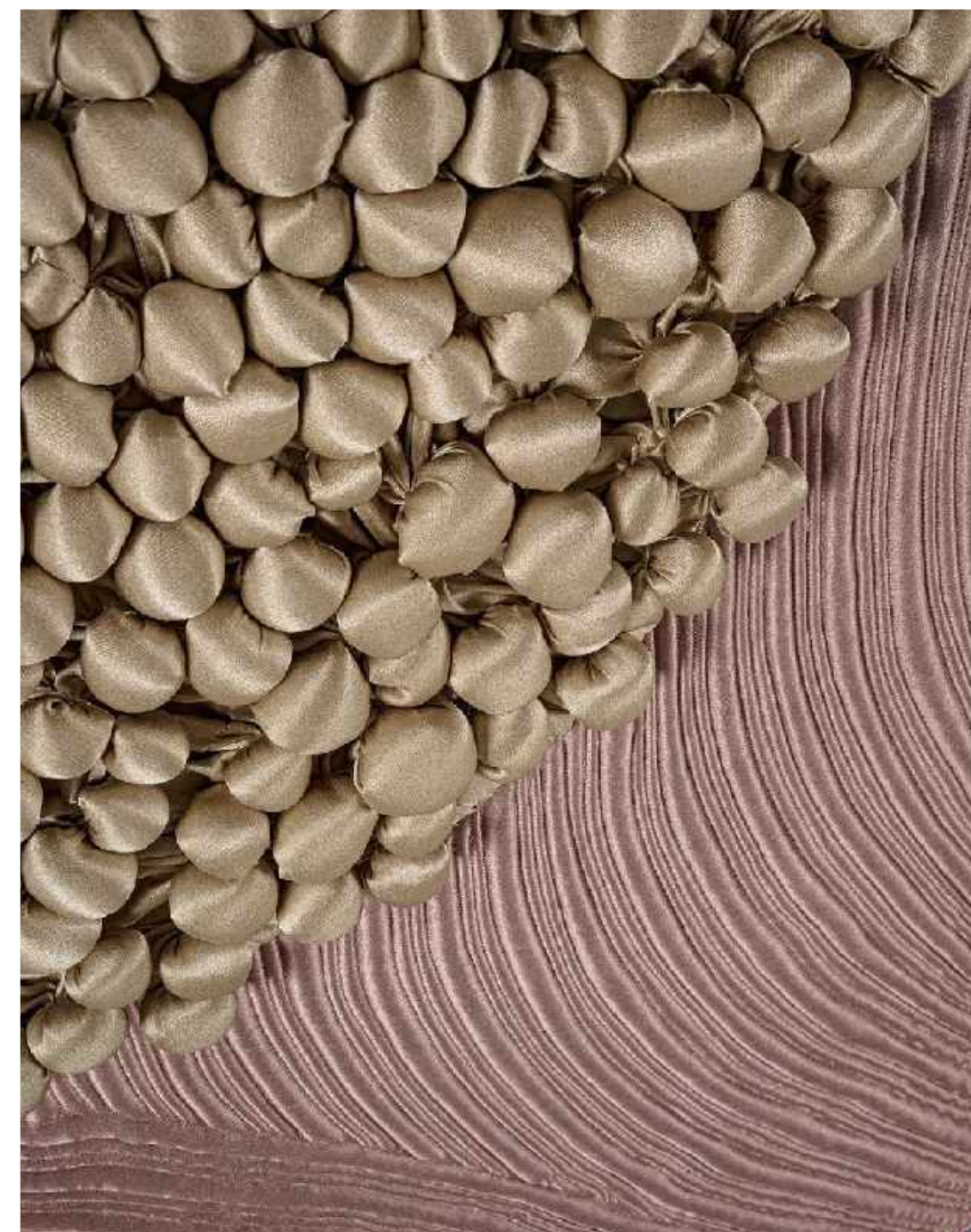



IPERBOREA | STUDIOPEPE





IPERBOREA | STUDIOPEPE

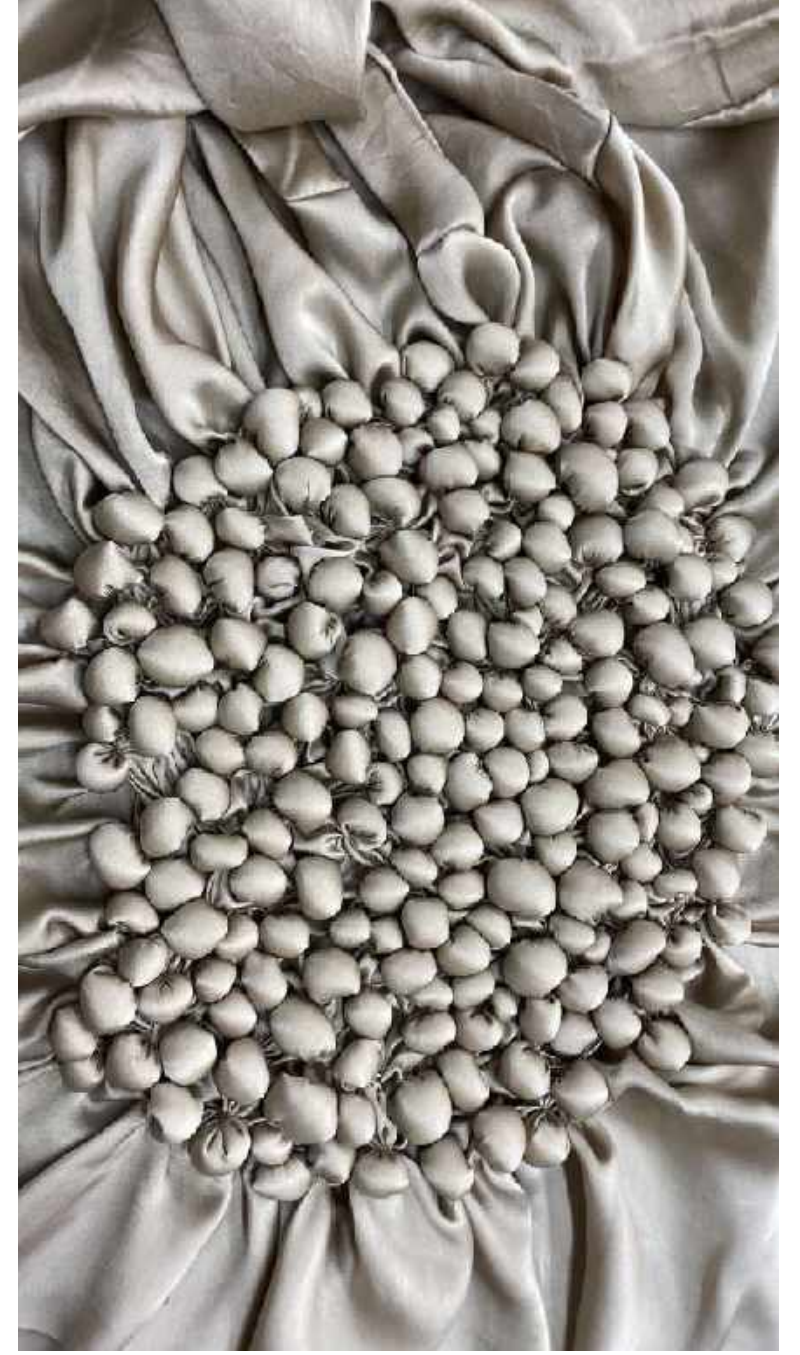
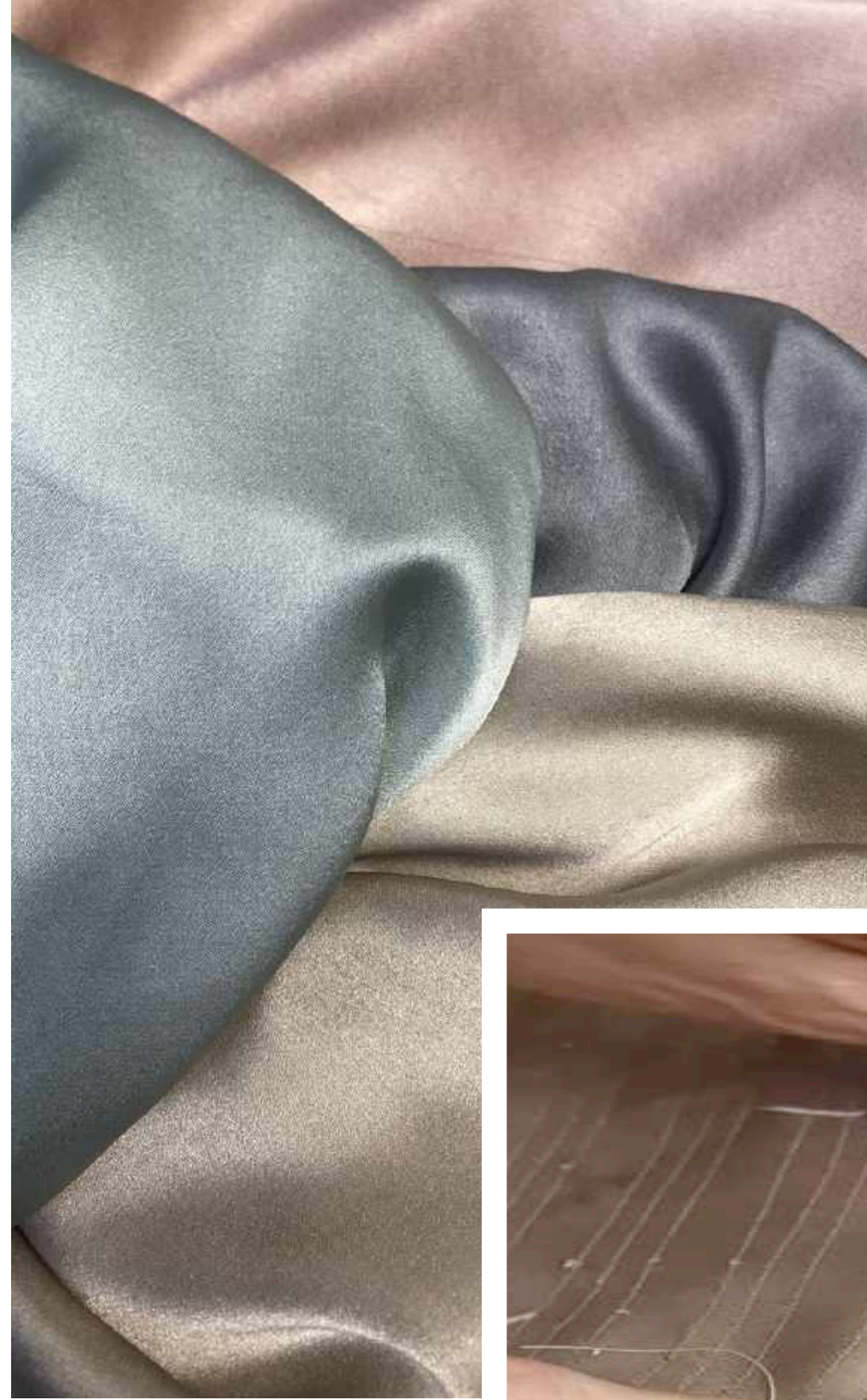

# Iperborea

DESIGN STUDIOPEPE

Wall hanging in pure silk, dyed with natural colors, embroidered by hand by prestigious Italian artisans.  
About 300 working hours are needed for each panel.  
It can be positioned horizontally or vertically.

## DIMENSIONS

Cm	Inches
180 x 5 x 200h	86¾" x 35½" x 27¾"h

## FINISHES



IPERBOREA | STUDIOPEPE



180

200

2024 COLLECTION

# SOCIAL ROOM

SALONE DEL  
MOBILE.MILANO  
2024



MDW 2024 | SALONE DEL MOBILE  
SOCIAL ROOM





2024 COLLECTION

# Fabric and leather Collection

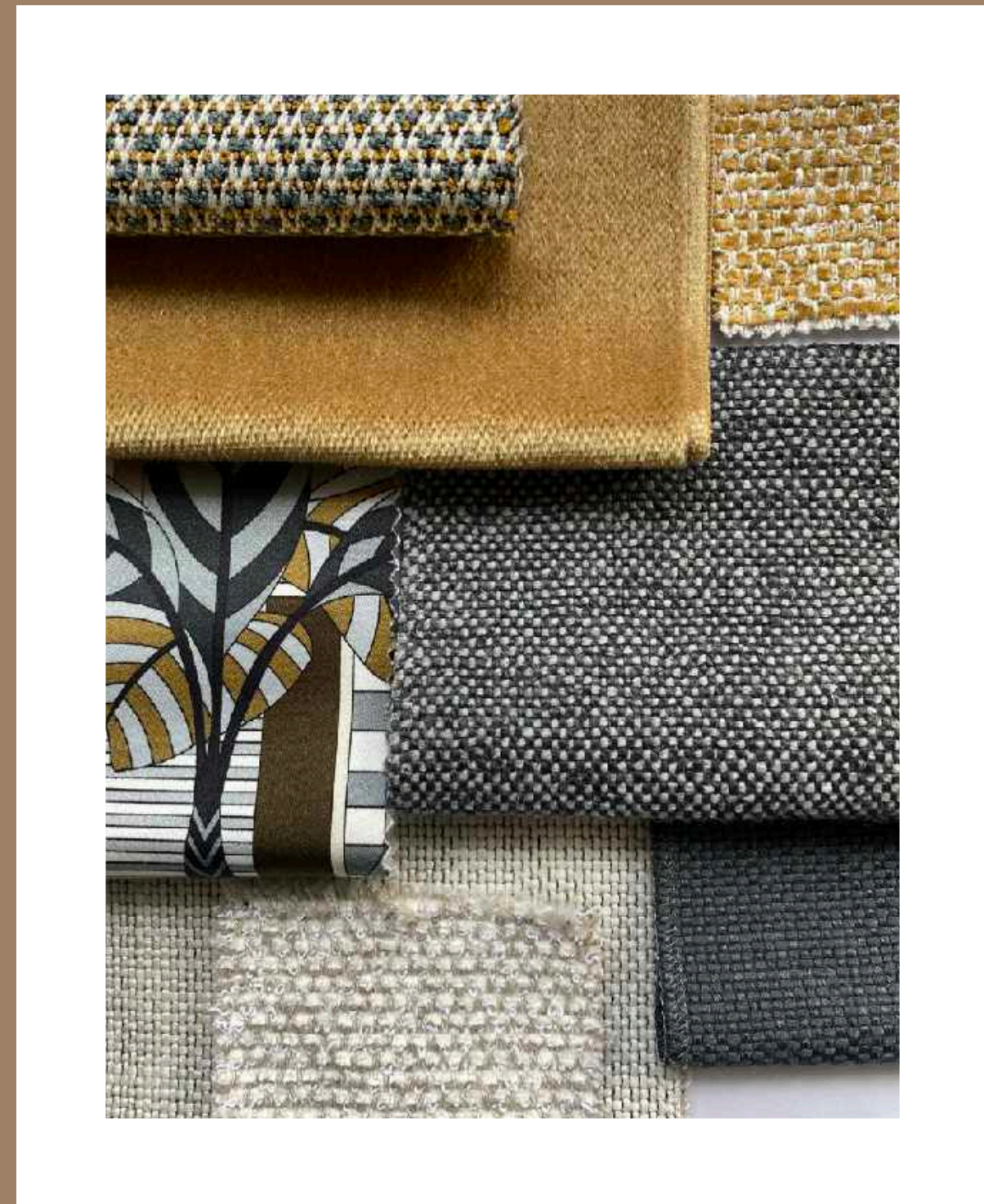



CAT.C / CAT.B

# ORIGINE /META

Origine milk 001

Meta milk 001

Origine sand 002

Meta sand 002

*Three-dimensionality and materiality are the basis of "Origine," a new textile project by Gallotti&Radice. From a background of linen and viscose, organic shapes emerge like atolls, in a refined play of balance and harmony. The main element is a soft chenille twisted with several threads and woven in different jacquard workings, which gives life to a surface with different thicknesses between them.*

*The three-dimensional effect of "Origin" generates a real visual and tactile sensory experience.*

*"Meta," with a dense diagonal chenille, is the united of the "Origine" fabric.*

Woven with **viscose linen warp woven with chenille**  
of microfiber that gives the article  
a **special softness**.

*The weaves used are canvas, satin and twill.*

*Twill is the second basic weave, with cloth and satin, has  
diagonal course, with a forehand and a backhand, one with  
weft effect and the other with warp effect.*

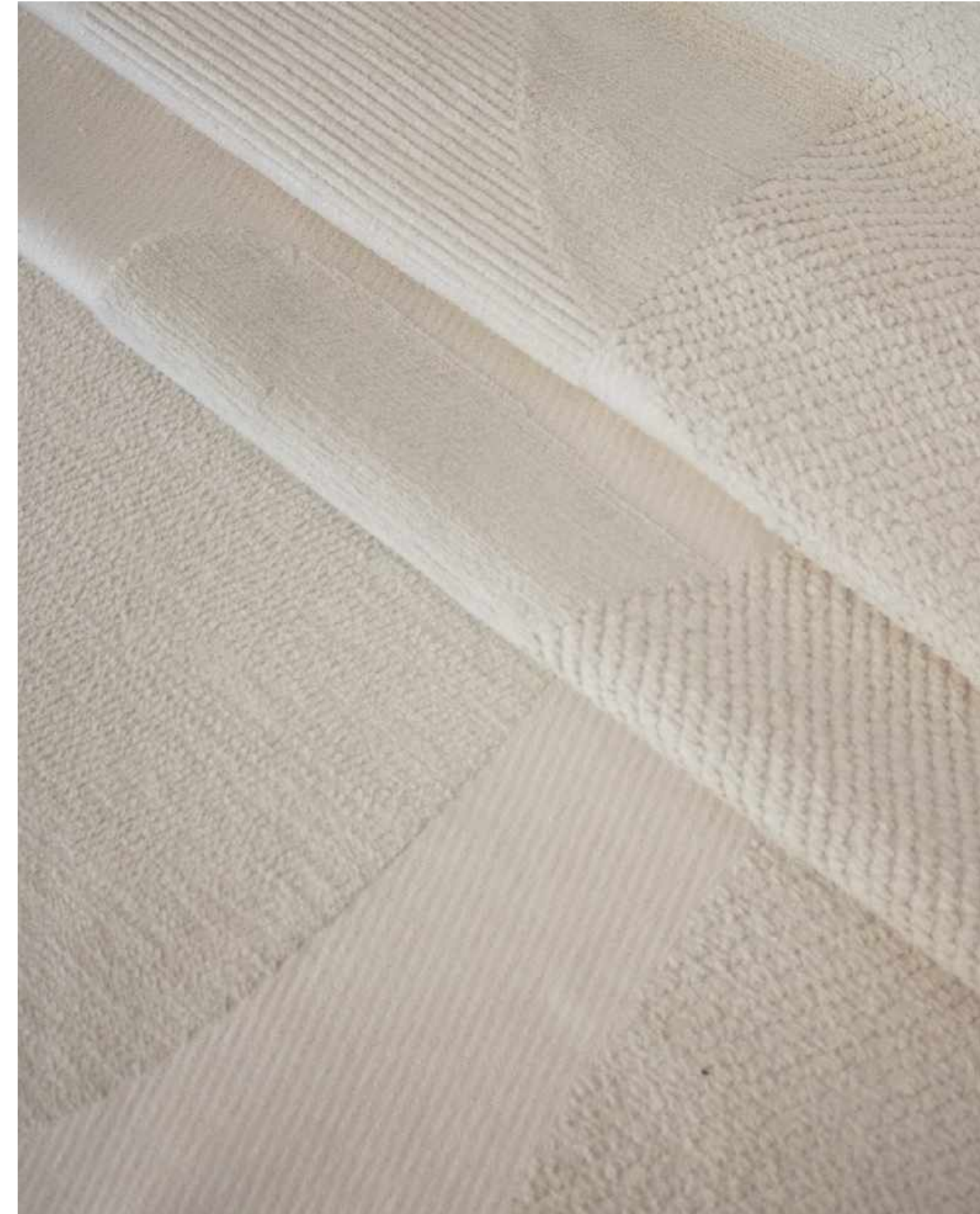



CAT.L1

# SOFT

Soft ecru 001

Soft clay 002

Soft deer 003

Soft amber 004

Soft anthracite 005

*This new leather is distinguished by its softness, elegance, elasticity and resistance to tearing.*

*Soft is very soft to the hand and a natural scribe that creates chiaroscuro capable of highlighting shapes and relief through variations in light and shadow.*



FABRIC AND LEATHER COLLECTION | SOFT

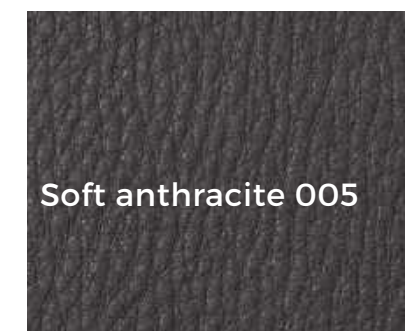
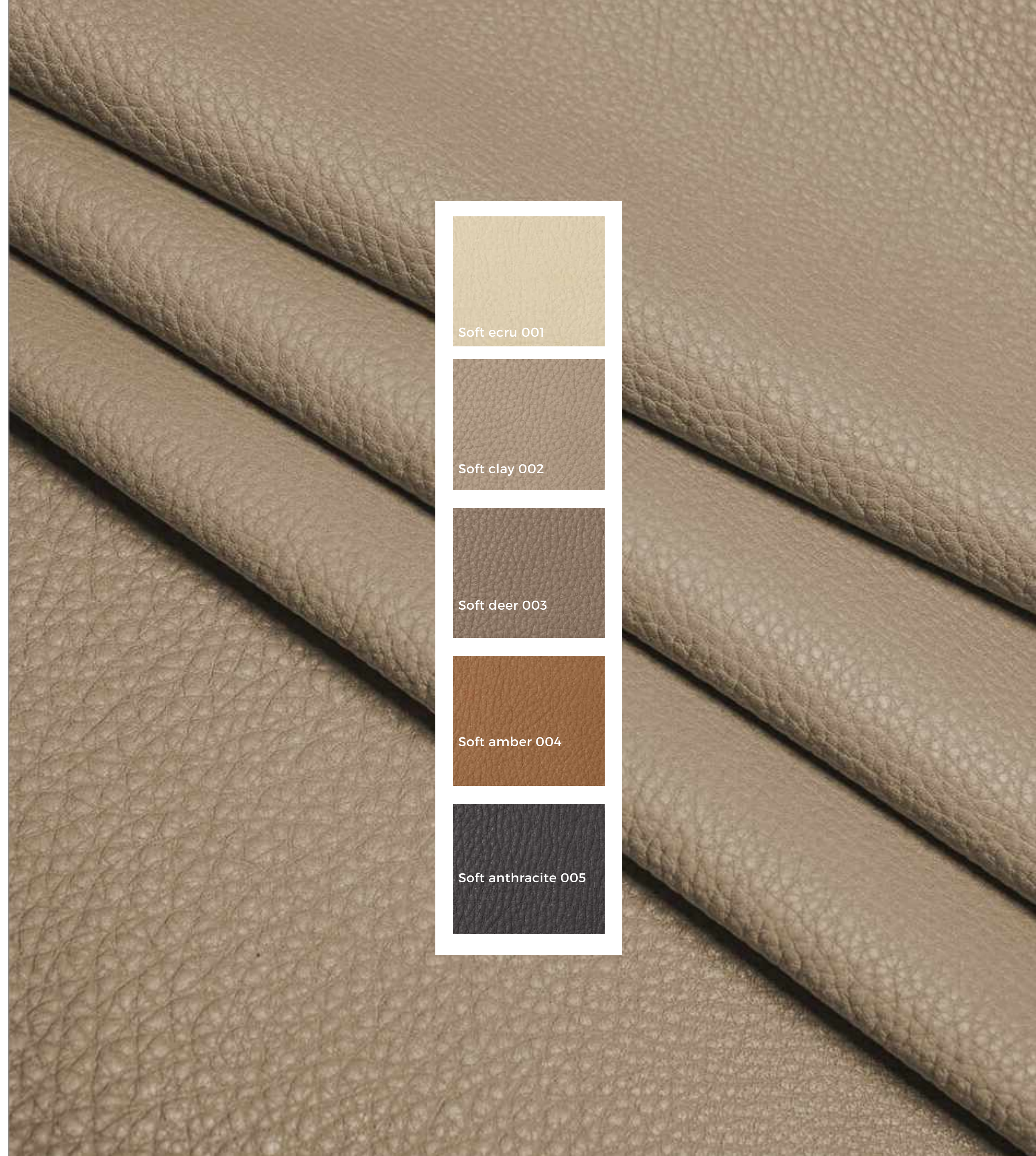



CAT.L1

# FARD

Fard ecru 2304  
Fard tan 2305  
Fard nude 2334  
Fard amber 2343  
Fard deer 2346  
Fard otter 2348

*Fard is an innovative leather specially designed to harmonize the nubuck appearance with high technical characteristics. Suitable for any type of application such as armchairs, sofas, furniture, desks, tables and objects, Fard resistant to dirt, abrasion and easy to clean.*

*In 2024 Gallotti&Radice implements the Fard family with 2 colors with light nuances and 4 colors that recall earth colors.*



FABRIC AND LEATHER COLLECCTION | FARD

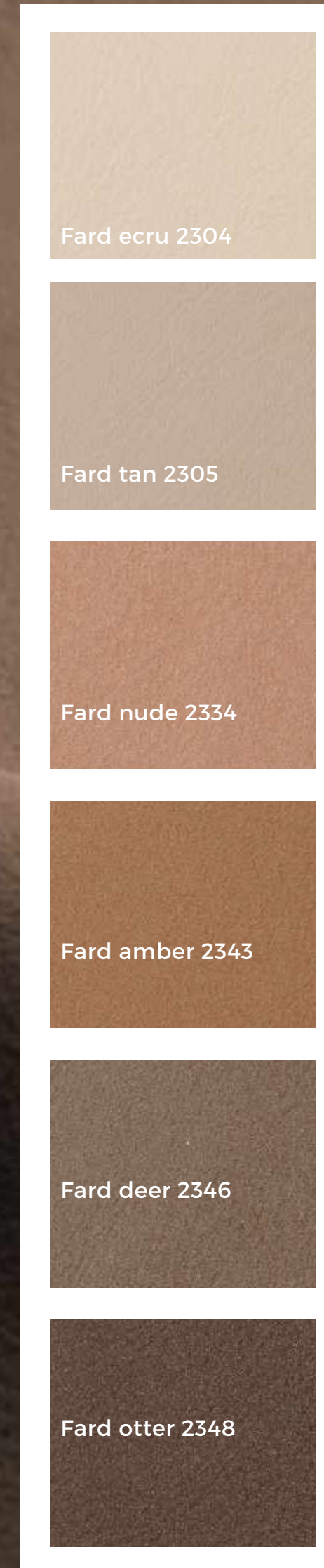



**Gallotti&Radice**

