

**Homescapes,
sense of materials.**

**Homescapes,
sense of materials.**

I materiali sono l'anima degli
homescapes in cui viviamo.
Graduale/a contrasto (p.6), Noto/
innovativo (p.42), Classico/avan-
guardia (p.58), Naturale/tecnologico
(p.86) sono quattro racconti
possibili per descriverne le qualità.
Immergiti.

**Materials
are the soul of the
homescapes
we live in. Gradual/
contrasting,^{p. 6}
Familiar/innovative,^{p. 42}
Classic/avant-garde,^{p. 58}
Natural/
technological^{p. 86}
are four possible
narratives
to describe their
qualities. Get ready
to explore.**

We love our domestic landscapes because we created them to meet our personal needs out of the objects we love. Furniture products of many different shapes and functions are a presence in our daily life and their distinctive identities and materials lend a special character to our surroundings. We would like to accompany you on a visual journey that looks at the materials, surfaces, tactile qualities and emotions that make up our collection. These four chapters are about unexpected material and chromatic contrasts, special production processes like innovative glass finishings, the revival of traditional techniques applied by craftsmen, our careful attention to the quality and cultural heritage of naturally precious Italian-made materials. We explore these themes through four pairs of opposites, because different elements occupying a single space or different materials within an object create a living dialogue: a balance between harmony and contrast. This collection of materials and exclusive finishings is examined through products, most of which are completely new, signed by Gallotti&Radice.

Amiamo i nostri paesaggi domestici perché sono il frutto, da noi creato, di necessità e amore per oggetti-presenze. Prodotti d'arredo molto diversi tra loro, per forma e funzione, abitano il nostro quotidiano con la propria identità distintiva, esprimendo la loro materia ed il loro carattere. Vogliamo accompagnarvi in un'esplorazione visiva sui materiali attraverso i valori di superficie, le qualità tattili, la natura emozionale della nostra collezione. Questi quattro capitoli riguardano i contrasti materici e cromatici inattesi, i processi di lavorazione speciali come le innovative finiture del vetro, il recupero di tecniche tradizionali applicate artigianalmente, la testimonianza della vigile attenzione al patrimonio culturale ed alla qualità Italian made dei materiali naturalmente preziosi. I temi sono indagati attraverso altrettante coppie opposte, perché la convivenza di presenze in uno spazio, o quella di più materiali in un oggetto, è un equilibrio dialettico vivo: si manifesta per armonia o contrasto. La collezione di materiali ed esclusive finiture è indagata attraverso prodotti, per la maggior parte inediti, firmati Gallotti&Radice.

Graduale/a contrasto. Accostiamo o mixiamo materiali differenti che si confrontino per contrasti cromatici e materici forti. Colori accesi, textures ricche, forme sofisticate compongono ambienti carichi di espressività e gusto.

Gradual/contrasting.
We juxtapose or mix different materials whose chromatic contrasts and bold materials make them stand out. Bright colors, rich textures, sophisticated forms combine to create environments that are expressive and tasteful.



Syll, shelving system
Audrey Poltrona, armchair

Audrey, sofa
Gong, coffee table

Haumea, coffee table
Eris, hanging lamp

Fante, coffee table

Syil, shelving system
Audrey Poltrona, armchair
Gong, coffee table
Haumea, coffee table





Haumea, coffee table
Eris, hanging lamp

Audrey, sofa
Gong, coffee table

Fante, coffee table

The exceptional depth of the texture Prussian Blue is the result of a skillful application of colored glazings. An initial colored layer is covered by a patina and then hand brushed to create an interlaced pattern. The final character is conveyed by a layer of transparent enamel with a touch of blue-green for a rich, sophisticated and unconventional visual experience.

L'eccezionale profondità della trama Prussian Blue è data da una sapiente applicazione di velature di colore. Un primo strato colorato viene coperto da una patina e successivamente spazzolata manualmente disegnando un intreccio. Il carattere finale viene conferito da una velatura di vernice trasparente dalle sfumature blu-verde, per una ricchezza sofisticata e un'inedita esperienza visiva.





Audrey, sofa
Fante, coffee table
Fabric Tokyo tobacco 203

Jolie, hanging lamp
Sophie, armchair

Cookies Circle, coffee table
Cookies, coffee table

Sophie Sofa
5th Avenue, storage unit







Cookies Circle, coffee table
Sophie, armchair
5th Avenue, storage unit



5th Avenue, storage unit







Mahon, sofa
Bolle Tavolo 3, table lamp
Pandora, Light, sideboard
Connection, coffee table
1968, coffee table
Brera, shelving system



Fabric Berlino moss 102

Fabric Kanti White
Fabric Velvet moss 7307





1968, coffee table
Marble Calacatta Vagli Oro Marble Verde Alpi

Powerfully iconic and highly sophisticated, with its changing nuances, the finishing Bronze Powder conveys a note of personality on the object it covers. When the bronze component of the finishing is applied, the natural process of oxidation produces an effect of fascinating unevenness, available in the two colors Lava and Avana.

Potentemente iconico e altamente sofisticato, con le sue sfumature mutevoli la finitura Polvere di Bronzo garantisce un contrappunto di personalità al prodotto su cui è applicata. La componente bronzea della vernice fa sì che nell'applicazione il naturale procedimento di ossidazione crei l'affascinante disomogeneità di trama, ottenibile nei due colori Lava e Avana.

Leaf, hanging sculpture

Mahon, sofa
Athus, console

Bronze powder, Lava
Bronze powder, Avana





Athos Console
Leaf, hanging sculpture

Noto/innovativo. Fin dalla sua fondazione il vetro ha fatto parte del dna di Gallotti&Radice. Conosciamo la materia e amiamo indagarla nelle sue infinite potenzialità, ampliando la gamma di finiture in un equilibrio indissolubile tra poesia e tecnica.

Familiar/innovative.
Glass has been an intimate part of Gallotti&Radice's identity since the company was founded. We know this material well and delight in investigating its potentials, expanding the range of finishings in an inseparable balance between poetry and technique.



Bolle Orizzontale,
hanging lamp

Thea, chair
Plattum System, table

The first coating on a glass or wooden plate is characterized by a metallic component. Then another darker layer is applied, which is manually polished and softened by our craftsmen using a special brush. This brings out the metal's noble qualities and gives the finishings Lead and Antique Bronze their distinctive depth and sheen.

La prima verniciatura su lastra di cristallo, o legno, è caratterizzata da una componente metallica. Un'ulteriore velatura più scura viene successivamente stesa, levigata manualmente e sfumata con una spazzola speciale dai nostri artigiani. Riaffiora così la nobile natura del metallo che dona alle finiture Piombo e Bronzo Antico distintiva profondità e riflessi lucenti.

Bolle Orizzontale,
hanging lamp

Thea, chair
Platinum System, table

Finish Lead
Finish Antique Bronze





Tortona, bookshelf

Dolm Plus, table
Narghilé, hanging lamp



The exclusive finishing Cashmere is obtained by applying a thick layer of lacquer to the glass which is then brushed in depth, evenly and uniformly. Cashmere is available in the warm shade of Gold-Grey or in the elegant Anthracite.

L'esclusiva finitura Cashmere è ottenuta applicando su cristallo un sostanzioso spessore di vernice, successivamente spazzolata in profondità in modo omogeneo e continuo. Il carattere materico che la contraddistingue richiama la morbidezza e la trama di un tessuto prezioso. Cashmere è disponibile nella nuance calda Gold-Grey oppure nell'elegante Anthracite.

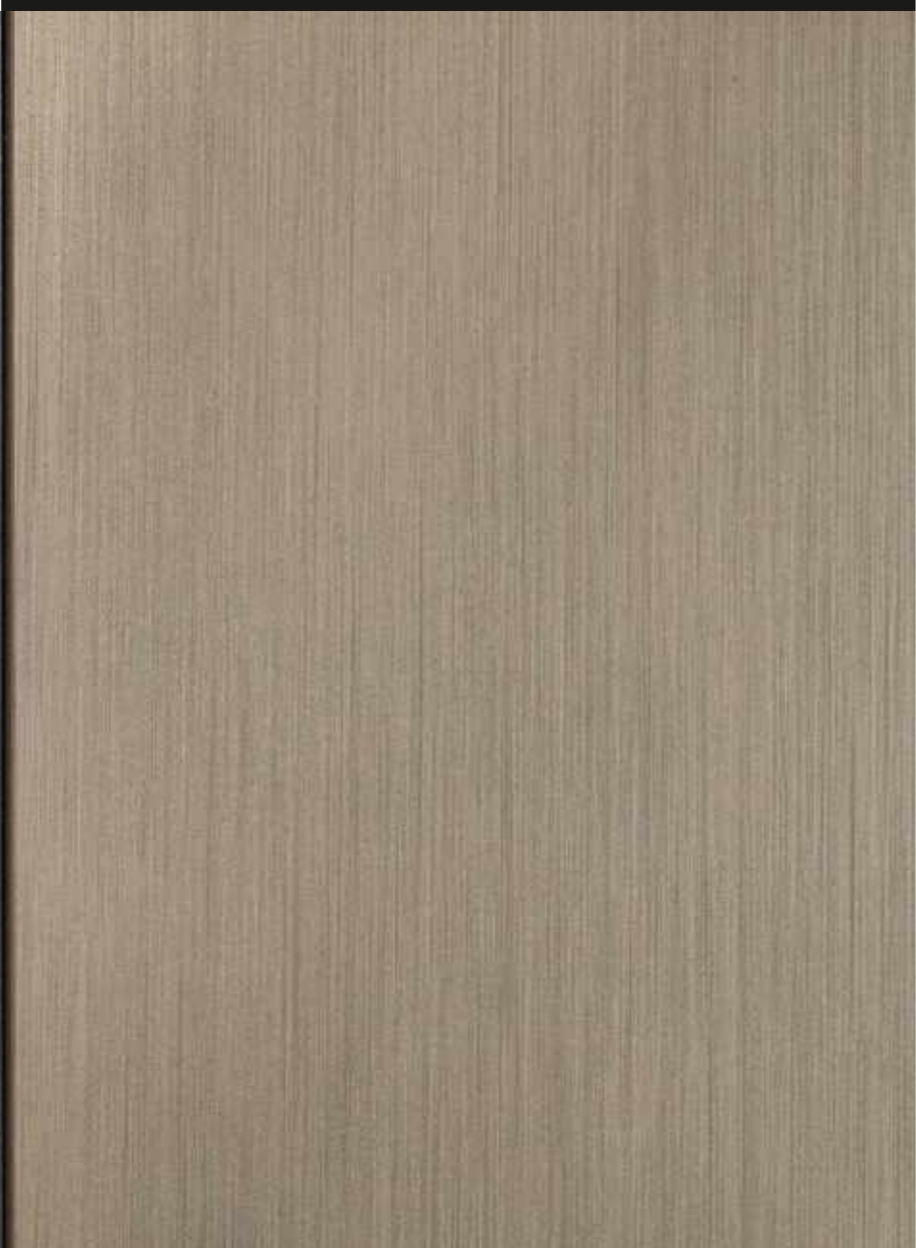



Narghiè, hanging lamp

Athus, sideboard
Dóim Plus, table



Classico/avanguardia. Amiamo scoprire applicazioni di tecniche antiche e interpretarle in chiave contemporanea. Per farlo ci affidiamo alle mani esperte dei migliori artigiani sul nostro territorio.

Classic/avant-garde.
We love to discover ancient technical applications and interpret them in a contemporary light. To do this we rely on the expert hands of the finest craftsmen in our region.



Bolle Tela, hanging lamp

0414, chair
Prism, table

Bolle Teta, hanging lamp

O414, chair
Prism, table



Inlay work is an ancient technique whose roots date back to the splendors of the Italian Renaissance, when it reached its height of expression, and the craft has continued to the present day. Here it is reinterpreted by combining prized rosewood with metal. The insertion of thin aluminum lamina between the plates creates a harmonious contrast that highlights the wood's natural grain.

Una tecnica ricca di storia quella dell'Intarsio, che affonda le radici della sua massima espressione artistica nei fasti del rinascimento italiano, fino ad arrivare ai giorni nostri, qui reinterpretata accostando pregiato legno di Palissandro e metallo. L'inserimento di sottili lamine di alluminio tra le lastre dell'essenza crea un contrasto armonico che risalta la naturale venatura del legno.





Nabuk.black.2138

0414, chair
Prism, table



Pandora Pergamena,
sideboard

Prism, table
0414, chair

Bolle Tela, hanging lamp



The ancient technique of parchment is revived experimentally: the parchment is skillfully applied to the transparent glass allowing its pattern to be seen on both sides of the plate. In the spirit of Art déco and with refined taste, the prized finishing Pergamena reveals signs of the animal's body and life, elements that make each piece unique.

L'antica lavorazione della pergamena viene rivisitata in prospettiva sperimentale: viene con sapienza applicata la pelle al cristallo trasparente lasciando scoprire la decorazione su entrambi i lati della lastra. Sapere Art déco e gusto raffinato, la preziosissima finitura Pergamena rivela i segni della corporatura dell'animale e della sua vita, elementi che rendono ogni pezzo unico.





Yuki, bed
Fante, coffee table
Bolle Sola, hanging lamp



Shield, screen

Fante, coffee table
Duale, wardrobe

Jolie Applique, wall lamp
Audrey Pour, pouffe









The careful selection of the veneer sheets that will determine the inlay's final design is entrusted to the masterful skill of our inlayers. The various naturally warm textures of walnut wood are joined manually to form a unique surface resulting in a perfect union. Every piece surprises with its uniqueness.

La delicata selezione delle lastre in essenza che determineranno il disegno finale dell'intarsio è affidata alla cura e alla maestria dei nostri intarsiatori. Le textures differenti e naturalmente calde del legno di Noce vengono unite manualmente per formare un'unica superficie raggiungendo un accostamento perfetto. È così che ogni pezzo conserva la sorpresa di scoprire la propria unicità.





Finish Tanganika White Frisé
Finish "Colore" Frisé Walnut Duale, wardrobe

Naturale/tecnologico. Un oggetto non è mai una realtà conclusa. Evolve nel tempo con una propria storia. È a partire da questa consapevolezza che uniamo le più ricercate lavorazioni alla naturale sensibilità dei materiali.

Natural/ technological.

An object never comes to an end. It evolves over time with its own story. Aware of this, we combine the most sophisticated processes with the natural character of our materials.



Fiona Soft, sofa
Golden Moon, coffee table
Brera, shelving system
Bolle tavolo 3, table lamp

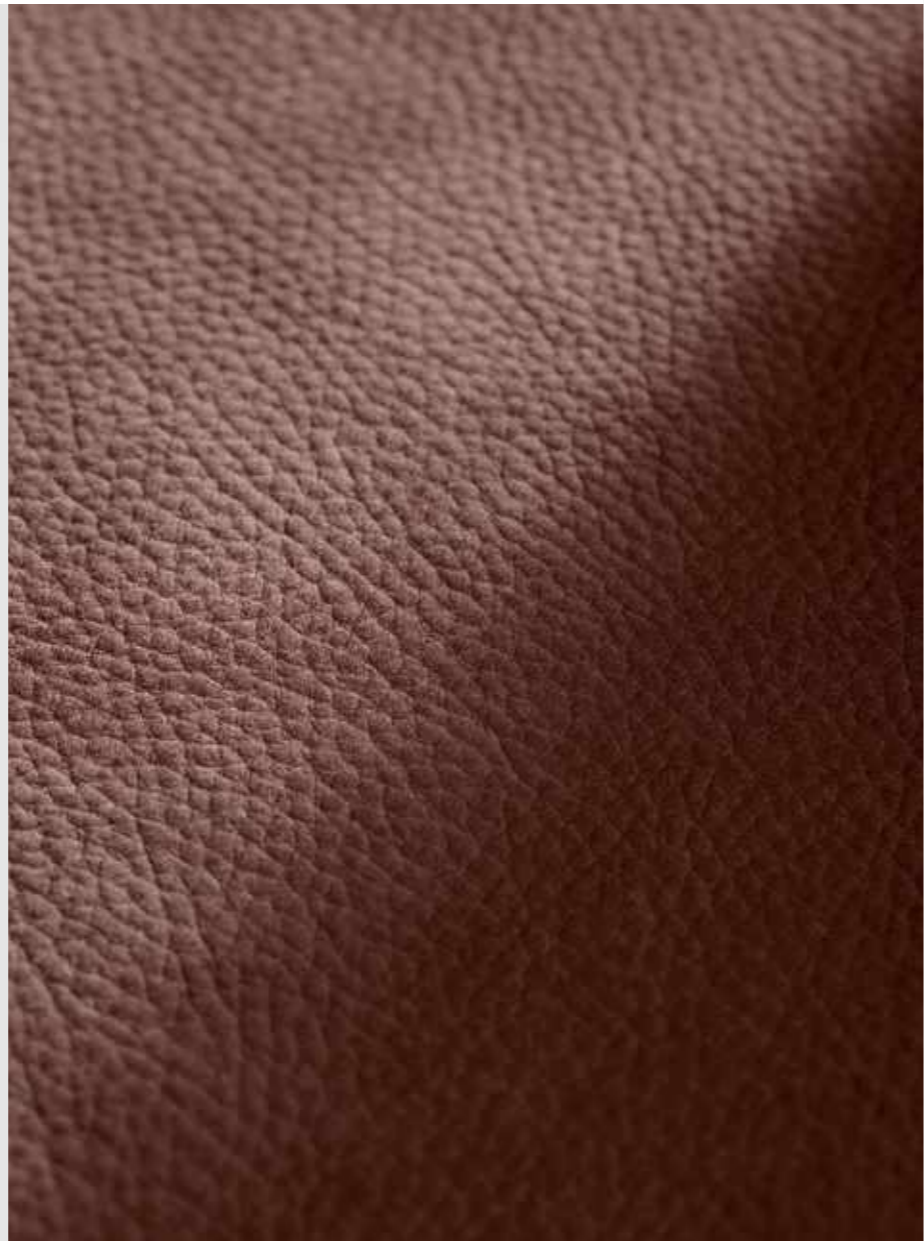



Fiona Soft, sofa
Brera, shelving system

Lou, pouffe
Zen, coffee table



Brera, shelving system

Fiona Soft, sofa
Golden Moon, coffee table





Brera, shelving system
Bolle Trela, hanging lamp

Oroschi, table
O414, chair

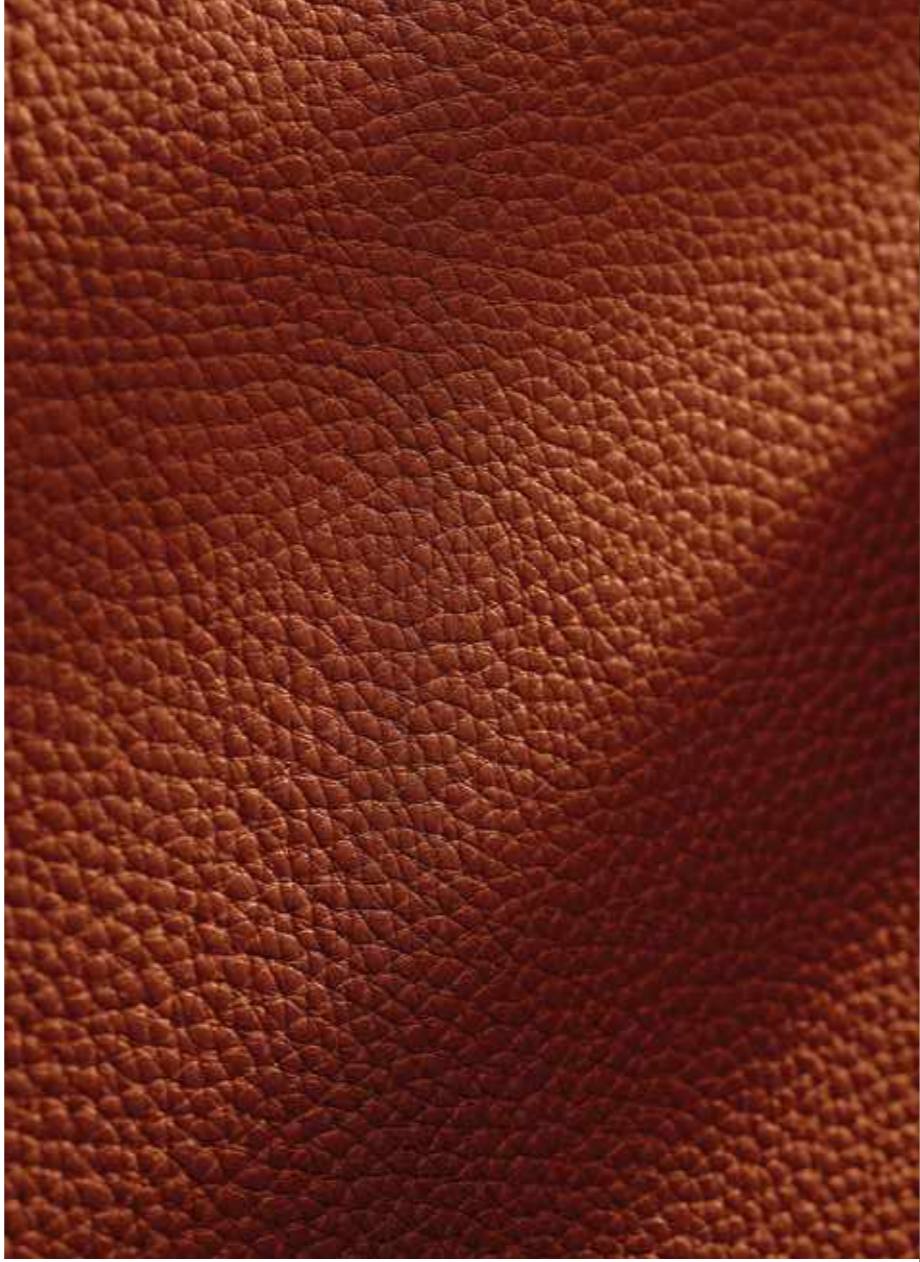



Brera, shelving system

0414, chair
Oroshi, table











Zeiss, mirror

Tama Console
Lou, pouffe

Navigli, shelving system

Thea Queen, chair
Dama, coffee table

Fante, coffee table
Twelve C, night table

Xeni, bed
Bolle Sola, hanging lamp





Twelve C, night table
Xeni, bed
Navigli, shelving system

Products Index
Indice dei prodotti

Tables

Tavoli

Dolm Plus pp. 51, 53, 54
Oroshi pp. 96, 100, 101
Platium System pp. 44, 47
Prism pp. 60, 63, 65, 66, 68

Seatings

Sedute

0414 pp. 60, 63, 65, 66, 96,
99, 100
Lou pp. 92, 108
Thea pp. 44, 47
Thea Queen pp. 111

Sofas and armchairs

Divani e poltrone

Audrey pp. 8, 12, 16
Audrey Poltrona pp. 8, 10
Audrey Pouf pp. 74, 81
Fiona Soft pp. 88, 90, 91, 93, 95
Mahon pp. 32, 39
Oly pp. 102, 104, 107
Sophie pp. 18, 22
Sophie Sofa pp. 19, 29, 30

Coffee tables

Tavolini

1968 pp. 33, 36, 37
Connection pp. 32
Cookies pp. 19, 23
Cookies Circle pp. 18, 22, 26, 27,
29, 81
Dama pp. 111
Fante pp. 9, 12, 16, 73, 110
Golden Moon pp. 88, 95
Gong pp. 8, 11, 12
Haumea pp. 9, 10, 12
Twelve C pp. 110, 112
Zen pp. 92

Lightings

Lampade

Bolle Orizzontale pp. 44, 47, 48
Bolle Sola pp. 73, 110
Bolle Tavolo 3 pp. 32, 89
Bolle Tela pp. 60, 63, 66, 68
Eris pp. 9, 12
Jolie pp. 18, 20, 21
Jolie Applique pp. 74, 76, 77
Narghilè pp. 51, 54

Consoles

Consolle

Athus Console pp. 39, 40, 41
Tama Console pp. 108

Storage units

Contenitori

5th Avenue pp. 19, 23, 24, 25
Athus pp. 54, 57
Duale pp. 74, 81, 83, 84
Pandora Light pp. 32
Pandora Pergamena pp. 65, 66,
68, 69, 71

Shelving systems

Librerie

Brera pp. 33, 88, 92, 95, 96, 99,
100, 102, 107
Navigli pp. 111, 113
Syil pp. 8, 10, 15
Tortona p.51

Beds

Letti

Yuki pp. 72
Xeni pp. 110, 112

Complements

Complementi

Leaf pp. 39, 40, 41
Shield pp. 74, 78, 79
Zeiss pp. 108

Credits

Graphic design
Studio CCRZ

Photography
Matteo Imbriani
Studio CCRZ

Styling
Elisa Ossino Studio
Studio G&R

Photoengraving
Monogramma

Printing
Grafica Gioia

© 2019
Gallotti&Radice

Technical data

Schede tecniche

Tables Tavoli

Dolm Plus

Oscar e Gabriele Buratti
2019

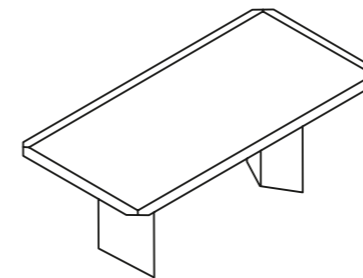

Cm (LxPxH)
200 x 90 x 74
200 x 100 x 74
240 x 90 x 74
240 x 100 x 74
280 x 110 x 74

Inches (WxDxH)
78¾" x 35½" x 29¼"
78¾" x 39½" x 29¼"
94½" x 35½" x 29¼"
94½" x 39½" x 29¼"
110¼" x 43½" x 29¼"

Table with 15mm glass top painted with the exclusive "Cashmere" brushed finish in the colours gold grey or anthracite. Also available in the exclusive finish antique bronze or lead. Large bevel of 6 cms on all the top edges. Wooden base covered by 6mm tempered painted glass.

Tavolo con piano in cristallo 15mm verniciato nella finitura esclusiva spazzolata "Cashmere" nei colori gold grey o anthracite oppure nella finitura esclusiva bronzo antico o piombo. Importante bisellatura di 6cm su tutti i lati del piano. Basi in legno rivestito in cristallo 6mm verniciato temperato.

pp. 51, 53, 54

Platium System

Oscar e Gabriele Buratti
2018

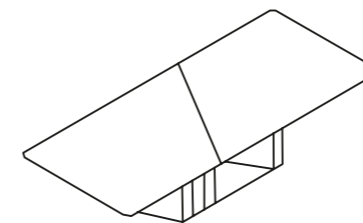

Cm (LxPxH)
260 x 120 x 74
280 x 120 x 74
300 x 120 x 74
360 x 120 x 74
400 x 120 x 74
460 x 120 x 74
500 x 120 x 74

Inches (WxDxH)
102½" x 47¼" x 29¼"
110¼" x 47¼" x 29¼"
118¼" x 47¼" x 29¼"
141¾" x 47¼" x 29¼"
157½" x 47¼" x 29¼"
181¼" x 47¼" x 29¼"
197" x 47¼" x 29¼"

Table with 15mm modular glass top and wooden base covered by 6mm glass, decorated by hand with an exclusive finish antique bronze and lead grey. Also available version with patinated bronze painted glass. Large bevel of 4cms on the two sides. Junction detail between tops in satin brass. "Supermirror" bright stainless steel bottom plate. Available version with wooden base covered by 20mm Sahara Noir, Stardust Grey or Calacatta Vagli Oro marble.

Tavolo con piano modulare in cristallo 15mm e base in legno rivestito in cristallo 6mm decorato a mano nella finitura esclusiva bronzo antico e piombo. Disponibile anche versione in cristallo verniciato bronzo patinato. Importante bisellatura di 4cm su due lati del piano. Dettaglio di giunzione tra i piani in ottone satinato. Piatto a terra in acciaio inox lucido "supermirror". Disponibile versione con base in legno rivestito in marmo 20 mm Sahara Noir, Stardust Grey o Calacatta Vagli Oro.

pp. 44, 47

Prism

David / Nicolas
2019

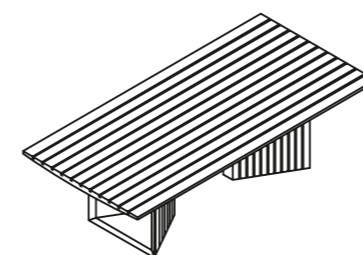

Cm (LxPxH)
260 x 125 x 74
280 x 125 x 74

Inches (WxDxH)
102½" x 49¼" x 29¼"
110¼" x 49¼" x 29¼"

Wooden table with modern and elegant marquetry of India rosewood and aluminium. The top features a distinctive bottom curve.

Tavolo in legno con moderno ed elegante intarsio di palissandro India e alluminio naturale. Caratteristica del piano, è l'importante curvatura inferiore.

pp. 60, 63, 65, 66, 68

Seatings Sedute

0414

Studio G&R
2014

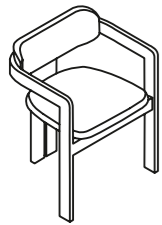

Cm (LxPxH)
57 x 52 x 75

Inches (WxDxH)
22½" x 20½" x 29¾"

Armchair with black lacquered open pore solid curved ash structure. Also available in natural ash, tobacco stained or white open pore lacquered ash. Seat and backrest with internal structure in wood and by-products with padding in non-deformable foam polyurethane in different densities. Covered by fabric or leather as per samples. Not removable cover.

Poltroncina con struttura in massello di frassino curvato tinto nero poro aperto. Disponibile anche in frassino naturale, tinto tabacco o tinto bianco poro aperto. Seduta e schienale con struttura interna in legno e derivati con imbottitura in poliuretano espanso indeformabile a densità differenziate. Rivestimento in tessuto o pelle nei colori del campionario. Non sfoderabile.

pp. 60, 63, 65, 66, 96, 99, 100

Thea

Pinuccio Borgonovo
2015

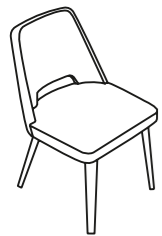

Cm (LxPxH)
50 x 57 x 81

Inches (WxDxH)
19¾" x 22½" x 32"

Chair with inside structure in wood and by-products padded in non-deformable foam polyurethane in different density and polyester fibre. Covered by fabric or leather as per samples. Black open pore lacquered oak legs. Not removable cover.

Sedia con struttura interna in legno e derivati, imbottita in poliuretano espanso indeformabile a densità differenziate e fibra poliestere. Rivestimento in tessuto o pelle nei colori del campionario. Gambe in rovere tinto nero poro aperto. Non sfoderabile.

pp. 44, 47

Thea Queen

Pinuccio Borgonovo
2016



Cm (LxPxH)
63 x 63 x 80
63 x 63 x 71

Inches (WxDxH)
25" x 25" x 31½"
25" x 25" x 28"

Armchair with inside structure in wood and by-products padded in non-deformable foam polyurethane in different density and polyester fibre. Covered by fabric or leather as per samples. Black open pore lacquered oak legs. Not removable cover.

Poltroncina con struttura interna in legno e derivati imbottita in poliuretano espanso indeformabile a densità differenziate e fibra poliestere. Rivestimento in tessuto o pelle nei colori del campionario. Gambe in rovere tinto nero poro aperto. Non sfoderabile.

p. 111

Sofas and armchairs Divani e Poltrone

Audrey

Massimo Castagna
2017

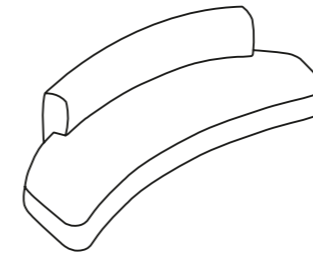

Cm (LxPxH)
207 x 109 x 75
245 x 125 x 75
270 x 135 x 75
320 x 156 x 75

Decorative cushion
Cuscino decorativo
40 x 40
60 x 60

Inches (WxDxH)
81½" x 43" x 29¾"
96½" x 49¼" x 29¾"
106½" x 53¼" x 29¾"
126" x 61½" x 29¾"

Decorative cushion
Cuscino decorativo
15¾" x 15¾"
23¾" x 23¾"

Sofa in non-deformable polyurethane foam in different density and polyester fibre with inside structure wood and by-products. Black coloured MDF base. Supplied with two backrest cushions in polyester fibre. Available covered by fabric or leather as per sample. Decorative polyester fibre cushions, on request. On demand removable fabric-cover.

Divano in poliuretano espanso indeformabile a densità differenziate e fibra poliestere con struttura interna legno e derivati. Basamento in mdf in massa nero. Fornito di due cuscini schienale in fibra poliestere. Disponibile con rivestimento in tessuto o pelle nei colori del campionario. Cuscini decorativi in fibra poliestere, su richiesta. Su richiesta rivestimento sfoderabile in tessuto.

pp. 8, 12, 16

Audrey Poltrona

Massimo Castagna
2018

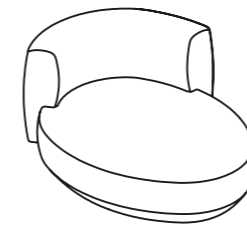

Cm (LxPxH)
102 x 84 x 68
122 x 97 x 68

Decorative cushion
Cuscino decorativo
40 x 40

Inches (WxDxH)
40¾" x 33¼" x 27"
48¾" x 38¼" x 27"

Decorative cushion
Cuscino decorativo
15¾" x 15¾"

Swivel armchair in non-deformable foam polyurethane in different densities and polyester fibre with wooden inside structure. A polyester fibre back cushion included. Black coloured MDF base. Available covered by fabric or leather as per sample. Decorative polyester fibre cushion, on request. On demand removable fabric cover.

Poltrona girevole in poliuretano espanso indeformabile a densità differenziate e fibra poliestere con struttura interna legno, fornita di un cuscino schienale in fibra poliestere. Basamento in mdf in massa nero. Disponibile con rivestimento in tessuto o pelle nei colori del campionario. Cuscino decorativo in fibra poliestere, su richiesta. Su richiesta rivestimento sfoderabile in tessuto.

pp. 8, 10

Audrey Pouf

Massimo Castagna
2019

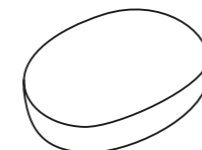

Cm (LxPxH)
100 x 80 x 38
118 x 95 x 38

Inches (WxDxH)
39½" x 31½" x 15"
46½" x 37½" x 15"

Pouffe in non-deformable foam polyurethane in different density and polyester fibre with wooden inside structure. Black coloured MDF base. Available covered by fabric or leather as per sample. On demand removable fabric cover.

Pouf in poliuretano espanso indeformabile a densità differenziate e fibra poliestere con struttura interna legno. Basamento in mdf in massa nero. Basamento in legno laccato nero. Disponibile con rivestimento in tessuto o pelle nei colori del campionario. Su richiesta rivestimento sfoderabile in tessuto.

pp. 74, 81

Fiona Soft

Massimo Castagna
2018

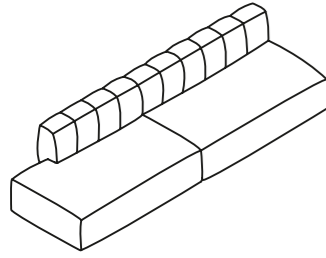

Modular sofa in non-deformable foam polyurethane in different density and polyester fibre with wooden inside structure. Black lacquered wooden feet. Back with vertical linear seams. Mixed down-padding backrest cushions. Available covered by fabric or leather as per sample. Decorative polyester fibre cushions, on request.

Divano modulare in poliuretano espanso indeformabile a densità differenziate e fibra poliestere con struttura interna in legno. Piedi in legno laccato nero. Schienale con cuciture lineari verticali. Cuscini schienale misto piuma. Disponibile con rivestimento in tessuto o pelle nei colori del campionario. Cuscini decorativi in fibra poliestere, su richiesta.

	Cm (LxPxH)	Inches (WxDxH)
	Module-Modulo	Module-Modulo
A	120 x 100 x 71 170 x 100 x 71 220 x 100 x 71	47¼" x 39½" x 28" 67" x 39½" x 28" 86¾" x 39½" x 28"
B	170 x 100 x 71 220 x 100 x 71	67" x 39½" x 28" 86¾" x 39½" x 28"
C	170 x 100 x 71 220 x 100 x 71	67" x 39½" x 28" 86¾" x 39½" x 28"
D	120 x 100 x 71 170 x 100 x 71 220 x 100 x 71	47¼" x 39½" x 28" 67" x 39½" x 28" 86¾" x 39½" x 28"
E	170 x 100 x 71	67" x 39½" x 28"
F	100 x 170 x 71	39½" x 67" x 28"
G	100 x 170 x 71	39½" x 67" x 28"
	Decorative cushion Cuscino decorativo	Decorative cushion Cuscino decorativo
	40 x 40 60 x 60	15¾" x 15¾" 23¾" x 23¾"

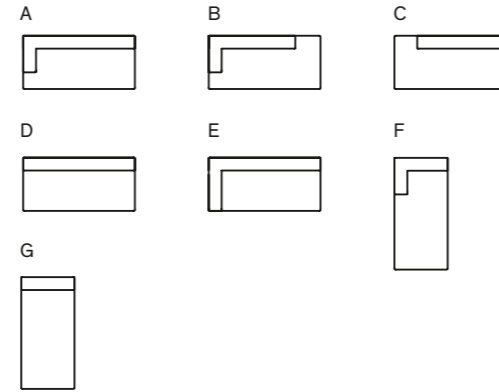

pp. 88, 90, 91, 93, 95

Oly

Massimo Castagna
2019

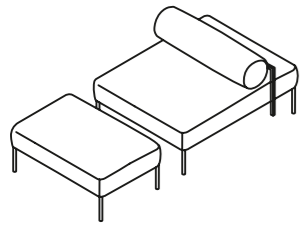

	Cm (LxPxH)	Inches (WxDxH)
	Bench -Panca	Bench-Panca
	78 x 97 x 62	30¾" x 38¼" x 24½"
	Pouffe -Pouf	Pouffe-Pouf
	78 x 52 x 43	30¾" x 20½" x 17"
	Decorative cushion Cuscino decorativo	Decorative cushion Cuscino decorativo
	40 x 40	15¾" x 15¾"

Bench and pouffe with bronzed black metal structure. Seat cushion in non-deformable foam polyurethane in different density and polyester fibre and back rollcushion covered by fabric or leather as per samples. Decorative polyester fibre cushions, on request.

Panca e pouf con struttura in metallo nero bronzato. Cuscino di seduta in poliuretano espanso indeformabile a densità differenziate e fibra poliestere e cuscino schienale a rullo rivestiti in tessuto o pelle nei colori del campionario. Cuscino decorativo in fibra poliestere su richiesta.

pp. 102, 104, 107

Sophie

Federica Biasi
2018

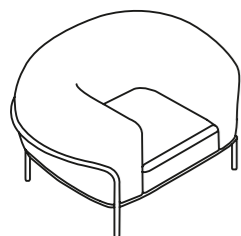

	Cm (LxPxH)	Inches (WxDxH)
	115 x 95 x 70	45½" x 37½" x 27¾"

Armchair with non-deformable polyurethane foam in different density and polyester fibre. Removable cover in fabric as per samples. Satin brass or anthracite grey lacquered metal structure.

Poltrona con imbottitura in poliuretano espanso indeformabile a densità differenziate e fibra poliestere. Rivestimento sfoderabile in tessuto nei colori del campionario. Struttura in metallo laccato ottone satinato oppure grigio antracite.

pp. 18, 22

Sophie Sofa

Federica Biasi
2019

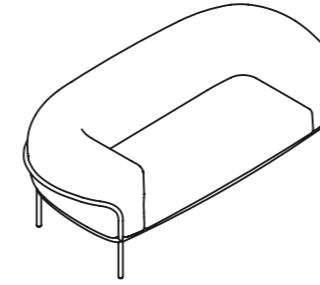

Cm (LxPxH)
170 x 95 x 70

Inches (WxDxH)
67" x 37½" x 27¾"

Small sofa with non-deformable polyurethane foam in different density and polyester fibre. Removable cover in fabric as per samples. Satin brass or anthracite grey lacquered metal structure.

Divanetto con imbottitura in poliuretano espanso indeformabile a densità differenziate e fibra poliestere. Rivestimento sfoderabile in tessuto nei colori del campionario. Struttura in metallo laccato ottone satinato oppure grigio antracite.

pp. 19, 29, 30

Coffee tables

Tavolini

1968

Studio G&R
2019

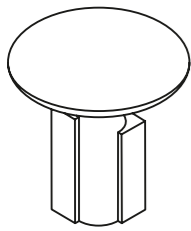

Cm (LxPxH)
Ø49 x 45
Ø49 x 50

Inches (WxDxH)
Ø19½" x 17¾"
Ø19½" x 19¾"

Coffee table with Verde Alpi, Calacatta Vagli Oro or Nero Marquinia marble top. Hand burnished brass structure with black open pore lacquered wooden parts.

Tavolino con piano in marmo Verde Alpi, Calacatta Vagli Oro o Nero Marquinia. Struttura in ottone brunito a mano e parti in legno laccato nero poro aperto.

pp. 33, 36, 37

Connection

Massimo Castagna
2013

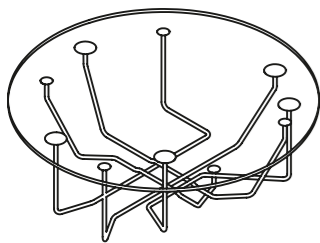

Cm (LxPxH)
Ø100 x 32
Ø130 x 32
Ø50 x 46,5
Ø70 x 39,5

Inches (WxDxH)
Ø39½" x 12¾"
Ø51¼" x 12¾"
Ø19¾" x 18½"
Ø27¾" x 15¾"

Coffee table with extralight tempered glass. Structure in hand burnished brass. The hand burnished brass finish looks naturally spotted and irregular. Due to this craftmade processing, each product is unique and exclusive.

Tavolino in cristallo extralight temperato. Struttura in ottone brunito a mano. L'ottone risulta naturalmente macchiato e disomogeneo. Questa lavorazione artigianale conferisce ad ogni pezzo una particolare unicità, rendendolo esclusivo.

100 x 100 x 32
130 x 130 x 32
140 x 70 x 32
180 x 76 x 32

39½" x 39½" x 12¾"
51¼" x 51¼" x 12¾"
55 ¼" x 27 ¾" x 12¾"
71" x 30" x 12¾"

Double-Doppio
107 x 70 x 46,5

Double-Doppio
42½" x 27¾" x 18½"

p. 32

Cookies

Pietro Russo
2017

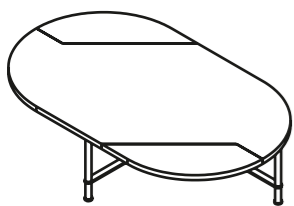

Cm (LxPxH)
70 x 42 x 40
105 x 62 x 28
120 x 72 x 23
144 x 86 x 35

Inches (WxDxH)
27¾" x 16¾" x 15¾"
41½" x 24½" x 11¼"
47½" x 28½" x 9¼"
56¾" x 34" x 14"

Coffee table with natural polished Bianco Statuario and Nero Marquinia marble inlaid top. Also available with inlaid wooden top with "Tweed" pattern, in Taba Frisé white wood and Tanganika black wood or in Maple Frisé dark grey. Black hand brushed anodised aluminium and bright brass structure.

Tavolino con piano in marmo lucido naturale Bianco Statuario e Nero Marquinia intarsiato. Disponibile anche con piano in legno intarsiato con motivo "Tweed", in Taba Frisé bianco e Tanganika nero oppure in Acero Frisé grigio scuro. Struttura in alluminio spazzolato a mano e anodizzato nero ed ottone lucido

pp. 19, 23

Cookies Circle

Pietro Russo
2019

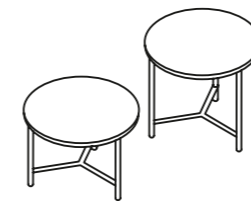

Cm (LxPxH)
Ø49 x 35
Ø49 x 45

Inches (WxDxH)
Ø19½" x 14"
Ø19½" x 17¾"

Coffee table with Verde Alpi, Calacatta Vagli Oro, Bianco Statuario or Nero Marquinia marble top. Also available with inlaid wooden top in the finish "Colore" Frisé Walnut or in Maple Frisé dark grey. Black hand brushed anodised aluminium and bright brass structure.

Tavolino con piano in marmo Verde Alpi, Calacatta Vagli Oro, Bianco Statuario o Nero Marquinia. Disponibile anche con piano in legno intarsiato nella finitura Noce Colore Frisé oppure Acero Frisé grigio scuro. Struttura in alluminio spazzolato a mano anodizzato nero ed ottone lucido.

pp. 18, 22, 26, 27, 29, 81

Dama

Studio G&R
2015

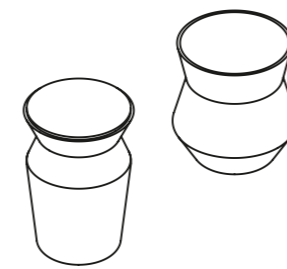

Cm (LxPxH)
S Ø41 x 45
L Ø38 x 55

Inches (WxDxH)
Ø16¼" x 17¾"
Ø15" x 21¾"

Marmo - Marble
S Ø41 x 46
L Ø38 x 56

Marmo - Marble
Ø16¼" x 18¼"
Ø15" x 22¼"

Coffee table in black lacquered open pore solid wood. Smoked "grigio Italia" mirrored top. Also available in "Antique 1" mirror, Calacatta Vagli Oro or Verde Alpi marble.

Tavolino in legno massello laccato nero poro aperto. Piano in specchio "grigio Italia". Disponibile anche in specchio "Antique 1" oppure marmo Calacatta Vagli Oro o marmo Verde Alpi.

p. 111

Fante

Studio G&R
2015



Cm (LxPxH)
S Ø46 x 50
L Ø38 x 63

Inches (WxDxH)
Ø18¼" x 19¾"
Ø15" x 25"

Marmo - Marble
S Ø46 x 51
L Ø38 x 64

Marmo - Marble
Ø18¼" x 20¼"
Ø15" x 25¼"

Coffee table in black lacquered open pore solid wood. Smoked "grigio Italia" mirrored top. Also available in "Antique 1" mirror, Calacatta Vagli Oro or Verde Alpi marble.

Tavolino in legno massello laccato nero poro aperto. Piano in specchio "grigio Italia". Disponibile anche in specchio "Antique 1" oppure marmo Calacatta Vagli Oro o marmo Verde Alpi.

pp. 9, 12, 16, 73, 110

Golden Moon

Massimo Castagna
2015

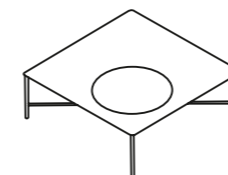

Cm (LxPxH)
100 x 60 x 35
100 x 100 x 35
130 x 70 x 35

Inches (WxDxH)
39½" x 23¾" x 14"
39½" x 39½" x 14"
51¼" x 27¾" x 14"

Coffee table with 12mm extralight tempered glass top or painted glass as per samples in the bright or satin version. Bright brass plate. Structure in hand burnished brass. The hand burnished brass finish looks naturally spotted and irregular. Due to this craftmade processing, each product is unique and exclusive. On request, version without bright brass plate.

Tavolino con piano in cristallo extralight temperato 12mm oppure retroverniciato nei colori del campionario, nella versione brillante o satinata. Disponibile anche con piano in cristallo "grigio Italia". Piatto in ottone lucido. Struttura in ottone brunito a mano. L'ottone risulta naturalmente macchiato e disomogeneo. Questa lavorazione artigianale conferisce ad ogni pezzo una particolare unicità, rendendolo esclusivo. Su richiesta versione senza piatto in ottone lucido.

pp. 88, 95

Gong	Cm (LxPxH)	Inches (WxDxH)	Wooden coffee table bevelled and decorated by hand with an exclusive treatment, available in "Autumn Weave" on gold leaf base or "Carbon Black" on copper leaf base version. Wooden base covered by gold leaf. Also available version "Winter Weave" on silver leaf base with wooden base covered by silver leaf.	Tavolino in legno bisellato e decorato con lavorazione manuale ed esclusiva, disponibile nella versione "Autumn Weave" su base foglia oro oppure "Carbon Black" su base foglia rame. Basamento in legno rivestito foglia oro. Disponibile anche versione "Winter Weave" su base foglia argento con basamento in legno rivestito in foglia argento.
	S Ø45 x 43	17¾" x 17"		
	M Ø70 x 31	27¾" x 12¼"		
	L Ø90 x 23	35½" x 9¼"		

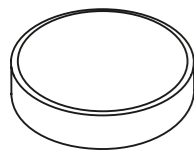

pp. 8, 11, 12

Haumea	Cm (LxPxH)	Inches (WxDxH)	Coffee table with 10mm extralight tempered glass top. Black open pore or rust lacquered wooden base. Bright brass, hand burnished brass, coppered brass or black chromed metal parts.	Tavolino con piano in cristallo extralight temperato 10mm. Base in legno laccato nero poro aperto o ruggine. Parti metalliche in ottone lucido, brunito a mano, ramato o cromo nero.
	XS Ø50 x 48	Ø19¾" x 19"		
	S Ø50 x 56	Ø19¾" x 22¼"		
	M Ø80 x 40	Ø31½" x 15¾"		
L Ø120 x 33	Ø47¼" x 13"			

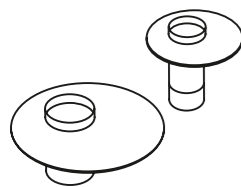

pp. 9, 10, 12

Twelve C	Cm (LxPxH)	Inches (WxDxH)	Black open pore lacquered ash night table. 6mm hand decorated Craquelé or bright liquorice painted glass top. Hand burnished brass structure.	Comodino in frassino laccato nero poro aperto. Piano in cristallo 6 mm decorato a mano nella finitura Craquelé oppure retroverniciato liquirizia brillante. Struttura in ottone brunito a mano.
	40 x 40 x 49	15¾" x 15¾" x 19½"		
	40 x 40 x 54	15¾" x 15¾" x 21½"		
	80 x 40 x 49	31½" x 15¾" x 19½"		

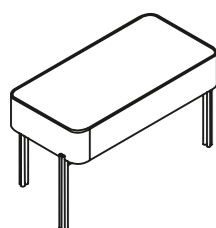

pp. 110, 112

Zen Low	Cm (LxPxH)	Inches (WxDxH)	Coffee table with black brushed lacquered ash top. Also available with hand decorated Craquelé glass top. Black hand brushed anodized aluminium base with bright brass plated details.	Tavolino con piano in frassino spazzolato laccato nero. Disponibile anche con piano in cristallo decorato a mano nella finitura Craquelé. Base in alluminio spazzolato a mano e anodizzato nero con dettagli ottonati lucidi.
	A Ø 100 x 47	Ø 39½" x 18¾"		
	B-C-D 90 x 90 x 47	35½" x 35½" x 18¾"		
	E 105 x 50 x 47	41½" x 19¾" x 18¾"		

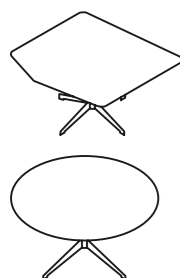

p. 92

Lightings Lampade

Bolle Orizzontale	Cm (LxPxH)	Inches (WxDxH)	Hanging lamp with dimmable LED light. 10 or 16 transparent blown glass spheres. Metal parts in hand burnished brass. The hand burnished brass finish looks naturally spotted and irregular. Supplied with cable 4mt long. Supplied with light bulbs (LED).	Lampada a sospensione a luce LED dimmerabile. Composta da 10 sfere oppure 16 sfere in cristallo trasparente soffiato a bocca. Parti metalliche in ottone brunito a mano. L'ottone risulta naturalmente macchiato e disomogeneo. In dotazione cavo di 4mt. Lampadine (LED) incluse.
	10 spheres-sfere 200 x 120 x 85	78¾" x 47¼" x 33½"		
	16 spheres-sfere 300 x 120 x 85	118¼" x 47¼" x 33½"		

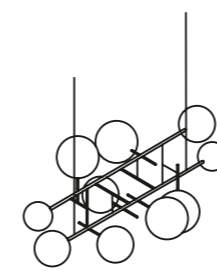

pp. 44, 47, 48

Bolle Sola	Cm (LxPxH)	Inches (WxDxH)	Hanging lamp with LED light (not dimmable). Transparent blown glass sphere. Metal parts in hand burnished brass. The hand burnished brass finish looks naturally spotted and irregular. Due to this craftmade processing, each product is unique and exclusive. Supplied with cable 4mt long. On request set of 3 or 5 lamps with unique canopy. Supplied with light bulbs (LED).	Lampada a sospensione a luce LED non dimmerabile. Sfera in cristallo trasparente soffiato a bocca. Parti metalliche in ottone brunito a mano. L'ottone risulta naturalmente macchiato e disomogeneo. Questa lavorazione artigianale conferisce ad ogni pezzo una particolare unicità, rendendolo esclusivo. In dotazione cavo da 4mt. Su richiesta realizzabili set da 3 e 5 lampade con un unico rosone. Lampadine (LED) incluse.
	Ø 20 x 50,5	Ø 8" x 20"		
	Ø 25 x 62	Ø 10" x 24½"		



pp. 73, 110

Bolle Tavolo 3	Cm (LxPxH)	Inches (WxDxH)	Table lamp with dimmable LED light. Transparent blown glass spheres. Metal parts in hand burnished brass. The hand burnished brass finish looks naturally spotted and irregular. Due to this craftmade processing, each product is unique and exclusive. Supplied with light bulbs (LED).	Lampada da tavolo a luce LED dimmerabile. Sfere in cristallo trasparente soffiato a bocca. Parti metalliche in ottone brunito a mano. L'ottone risulta naturalmente macchiato e disomogeneo. Questa lavorazione artigianale conferisce ad ogni pezzo una particolare unicità, rendendolo esclusivo. Lampadine (LED) incluse.
	58 x 52 x 44	23" x 20½" x 17½"		

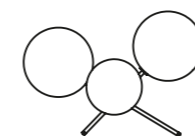

pp. 32, 89

Bolle Tela

Massimo Castagna
2018

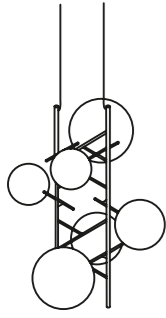

Cm (LxPxH)
6 spheres-sfere
85 x 70 x 100

8 spheres-sfere
85 x 75 x 180

Inches (WxDxH)
6 spheres-sfere
33½" x 27¾" x 39½"

8 spheres-sfere
33½" x 29¾" x 71"

Hanging lamp with dimmable LED light. 8 transparent blown glass spheres. Also available version with 6 spheres. Metal parts in hand burnished brass. The hand burnished brass finish looks naturally spotted and irregular. Supplied with cable 4mt long. Supplied with light bulbs (LED).

Lampada a sospensione a luce LED dimmerabile. 8 sfere in cristallo trasparente soffiato a bocca. Disponibile anche nella versione con 6 sfere. Parti metalliche in ottone brunito a mano. L'ottone risulta naturalmente macchiato e disomogeneo. In dotazione cavo di 4mt. Lampadine (LED) incluse.

pp. 60, 63, 66, 68

Eris

Massimo Castagna
2017



Cm (LxPxH)
Ø 35 x 180
Ø 35 x 210
Ø 35 x 250
Ø 35 x 280
Ø 35 x 320

Inches (WxDxH)
Ø 14" x 71"
Ø 14" x 82¾"
Ø 14" x 98½"
Ø 14" x 110¼"
Ø 14" x 126"

Hanging lamp with LED light (not dimmable) with black bronzed painted structure and bright, satin, hand-burnished and black chromed brass parts.

Lampada a sospensione a LED non dimmerabile con struttura verniciata nero bronzato e fasce in ottone lucido, satinato, brunito a mano e cromato nero.

pp. 9, 12

Jolie

Federica Biasi
2019



Cm (LxPxH)
Ø 60 x 62

Inches (WxDxH)
Ø 23¾" x 24½"

Hanging lamp with LED light composed by two dome shaped sections in Murano's mouth blown glass. Satin brass metal details. Supplied with cable 4mt long.

Lampada a sospensione LED composta da due calotte in vetro di Murano soffiato a bocca. Dettagli metallici in ottone satinato. In dotazione cavo da 4 mt.

pp. 18, 20, 21

Jolie Applique

Federica Biasi
2019

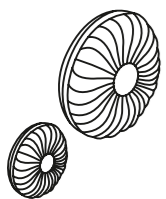

Cm (LxPxH)
Ø 20 x 11
Ø 30 x 15

Inches (WxDxH)
Ø 8" x 4½"
Ø 12" x 6"

Wall light in mouth blown glass. Satin brass metal details. LED light.

Applique in cristallo soffiato a bocca. Dettagli metallici in ottone satinato. Luce LED.

pp. 74, 76, 77

Consolle Console

Athus Console

Oscar e Gabriele Buratti
2013

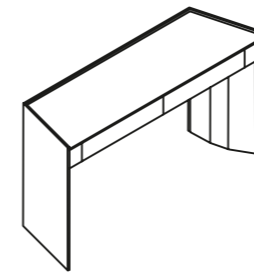

Cm (LxPxH)
150 x 46 x 80
180 x 46 x 80

Inches (WxDxH)
59¼" x 18¼" x 31½"
71" x 18¼" x 31½"

Console in black open pore lacquered ash, 6mm bright black painted glass top. Also available painted with the exclusive brushed "Cashmere" finish in the gold grey or anthracite colours. Total pull-out drawers with suede sand 006 bottom.

Console in frassino laccato nero poro aperto. Top in cristallo 6mm retroverniciato nero brillante. Disponibile anche laccato nella finitura esclusiva spazzolata "Cashmere" nei colori gold grey o anthracite. Cassetti ad estrazione totale con fondo in pelle scamosciata sand 006.

pp. 39, 40, 41

Tama Console

Carlo Colombo
2016

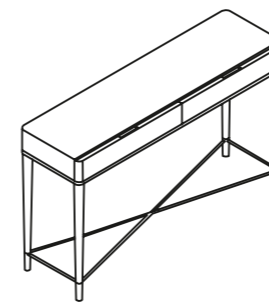

Cm (LxPxH)
120 x 36 x 83
140 x 36 x 83

Inches (WxDxH)
47¼" x 14¼" x 32¾"
55¼" x 14¼" x 32¾"

Console with black open pore lacquered ash drawers and satin brass lacquered metal parts. 6mm bright liquorice painted tempered glass top.

Console con cassetti in frassino tinto nero poro aperto con parti metalliche laccate ottone satinato. Top in cristallo 6mm temperato retroverniciato liquirizia brillante.

p. 108

Storage Units Contenitori

5th Avenue

Marcello Pozzi
2019

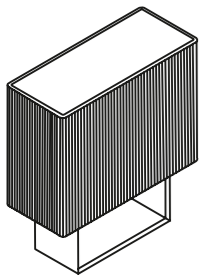

pp. 19, 23, 24, 25

Athus

Oscar e Gabriele Buratti
2017

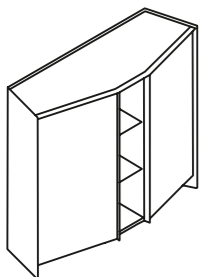

pp. 54, 57

Duale

Pietro Russo
2019

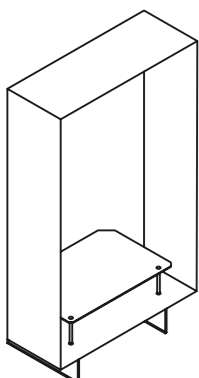

pp. 74, 81, 83, 84

Cm (LxPxH)
110 x 47 x 122

Inches (WxDxH)
43½" x 18¾" x 48¾"

Wooden unit covered by "supermirror" stainless steel in the black chrome finish with black lacquered open pore solid ash strips. Base in black open pore lacquered ash and internal part covered by "supermirror" stainless steel in the black chrome finish. Top with bevel in bright black painted smoked "grigio Italia" glass, 12mm, satin brass detail under the top. Supplied with extralight glass shelf and 6mm extralight mirrored glass inside back.

Madia in legno rivestita in acciaio inox "supermirror" nella finitura cromo nero con listelli in massello di frassino tinto nero poro aperto. Base in frassino laccato nero poro aperto e rivestita internamente in acciaio inox "supermirror" nella finitura cromo nero. Top in cristallo "grigio Italia" 12 mm bisellato retroverniciato nero brillante con dettaglio in ottone satinato. Dotata di ripiano interno in cristallo extralight e schienale interno in specchio 6mm extralight.

Cm (LxPxH)
125,5 x 57 x 136,5
155 x 57 x 136,5
250 x 57 x 75,5
300 x 57 x 48

Inches (WxDxH)
49½" x 22½" x 53¾"
61¼" x 22½" x 53¾"
98½" x 22½" x 29¾"
118¼" x 22½" x 19"

Sideboard in black open pore lacquered ash. Patinated bronze lacquered metal details. Stardust Grey or Sahara Noir marble top. Also available in 6mm tempered bright black painted glass. Supplied with 10mm tempered and bevelled extralight inside glass shelf. 6mm extralight mirror inside backs. Push-pull drawers with suede bottom just for versions 48h and 75,5h.

Madia in frassino laccato nero poro aperto. Dettagli in metallo verniciato bronzo patinato. Top in marmo Stardust Grey o Sahara Noir. Disponibile anche in cristallo temperato 6mm retroverniciato nero brillante. Dotata di ripiano interno in cristallo extralight 10mm bisellato temperato. Schienali interni in specchio 6mm extralight. Cassetti con fondo in pelle scamosciata e apertura push and pull solo per versioni 48h e 75,5h.

Cm (LxPxH)
100 x 57 x 180

Inches (WxDxH)
39½" x 22½" x 71"

Wardrobe in "Colore" Frisé Walnut inlaid wood. Inside covered by Tanganika white Frisé wood. Supplied with one clothes rail and wooden shelf or wooden multiple shelves.

Guardaroba a giorno in legno intarsiato Noce Colore Frisé. Interni rivestiti in Tanganika bianco Frisé. Accessoriato con appendiabiti e ripiano in legno oppure a più ripiani.

Pandora Light

Pinuccio Borgonovo
2016

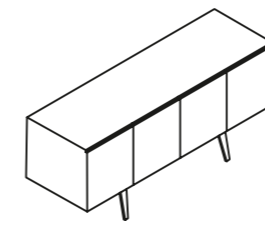

pp. 32

Cm (LxPxH)
162 x 52 x 71
162 x 52 x 100
162 x 52 x 126
202 x 52 x 71

Inches (WxDxH)
64" x 20½" x 28"
64" x 20½" x 39½"
64" x 20½" x 49¾"
79¾" x 20½" x 28"

Sideboard in 8mm extralight transparent tempered glass painted in patinated bronze. Supplied with 8mm extralight tempered glass shelves. Patinated bronze lacquered metal structure and handles. Wooden bottom shelf covered by gold leaf or brushed Emperador Brown marble. Collection in numbered edition.

Madia in cristallo 8mm extralight temperato, verniciata in bronzo patinato. Dotata di ripiani in cristallo 8mm extralight temperato. Struttura e maniglie in metallo verniciate bronzo patinato. Piano inferiore in legno rivestito in foglia oro oppure in marmo Emperador Brown spazzolato. Collezione in edizione numerata.

Shelving system

Librerie

Brera

Massimo Castagna
2016

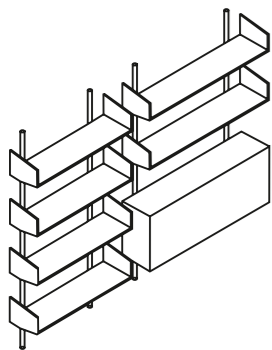

Wall shelving system with satin nickel-plated brass vertical supports. Clay stained or black open pore lacquered ash shelves. Door or flap door units with hand decorated tempered glass fronts in Deco' or Craquelé finish. Also available with painted glass fronts as per samples in the bright or satin version. With clay stained or black open pore lacquered ash TV Panel, on request. LED TV Panel (30 Watt) to be switched on with remote control.

Libreria con montanti verticali in ottone nichelato satinato. Ripiani in frassino tinto creta oppure tinto nero poro aperto. Contenitori ad anta o ribalta, con frontali in cristallo temperato decorato a mano, nella finitura Decò o Craquelé. Disponibile anche con frontali in cristallo retroverniciato nei colori del campionario, nella versione brillante o satinata. Su richiesta con pannello in frassino tinto creta o nero poro aperto per posizionamento tv. Il pannello è retro illuminato a LED (30 Watt) con accensione a telecomando.

Cm (L x P x H)
60cm versions with shelves and door
Versioni da 60cm a ripiani e anta
60 x 25 x 164/240

Inches (W x D x H)
60cm versions with shelves and door
Versioni da 60cm a ripiani e anta
23¾" x 10" x 64¾"/94½"

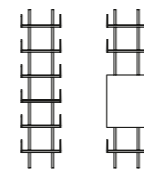

Cm (L x P x H)
Versions from 80 to 120cm with shelves and flap door
Versioni da 80 a 120cm a ripiani e ribalta
80 x 25 x 164/240
120 x 25 x 164/240

Inches (W x D x H)
Versions from 80 to 120cm with shelves and flap door
Versioni da 80 a 120cm a ripiani e ribalta
31½" x 10" x 64¾"/94½"
47¼" x 10" x 64¾"/94½"

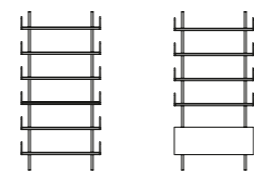

Cm (L x P x H)
160cm versions with flap door, shelves and TV panel
Versioni da 160cm con ribalta, mensole e pannello tv
160 x 25 x 164/240

Inches (W x D x H)
160cm versions with flap door, shelves and TV panel
Versioni da 160cm con ribalta, mensole e pannello tv
63" x 10" x 64¾"/94½"

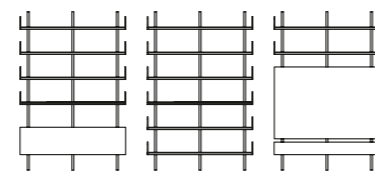

pp. 33, 88, 92, 95, 96, 99, 100, 102, 107

Navigli

Massimo Castagna
2015

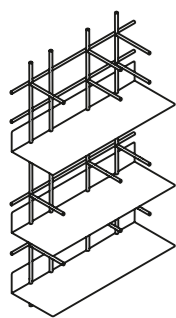

Cm (L x P x H)
70 x 24 x 120

Inches (W x D x H)
27¾" x 9½" x 47¼"

Wall shelving system with hand burnished copper structure and shelves. The hand burnished copper finish looks naturally spotted and irregular. Due to this craftmade processing, each product is unique and exclusive.

Available in two versions A and B.

Libreria a muro, con struttura e mensole in rame brunito a mano. Il rame risulta naturalmente macchiato e disomogeneo. Questa lavorazione artigianale conferisce ad ogni pezzo una particolare unicità, rendendolo esclusivo.

Disponibile in due versioni A e B.

pp. 111, 113

Syil

Oscar e Gabriele Buratti
2019

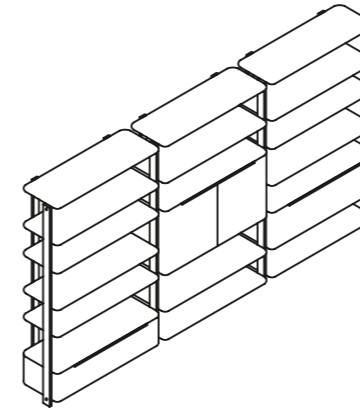

Cm (L x P x H)
123 x 47 x 70
123 x 47 x 132
123 x 47 x 158
123 x 47 x 194
123 x 47 x 256
183 x 47 x 158
183 x 47 x 194
183 x 47 x 256

Inches (W x D x H)
48½" x 18¾" x 23¾"
48½" x 18¾" x 52"
48½" x 18¾" x 62¼"
48½" x 18¾" x 76½"
48½" x 18¾" x 101"
72¼" x 18¾" x 62¼"
72¼" x 18¾" x 76½"
72¼" x 18¾" x 101"

Shelving system with black anodised aluminium supports with bright brass details. 8mm tempered shaped bright black painted smoked "grigio Italia" glass shelves. Wooden glossy lacquered door, flap door or drawer units in the artisanal and exclusive finish Prussian Blue or Cognac. Also available in the glossy lacquered version in the colours blue-grey, liquorice and black. Black open pore lacquered ash interior. Also available module with Tv panel and flap door unit, supplied with cable management, on request.

Sistema con montanti in alluminio anodizzato nero con dettagli in ottone lucido. Ripiani sagomati in cristallo grigio Italia 8 mm temperato retroverniciato nero brillante. Contenitori ad anta, ribalta o cassetto in legno laccato lucido nella finitura artigianale ed esclusiva Prussian Blue o Cognac. Disponibile anche nella versione laccata lucida nei colori blu grigio, liquirizia e nero. Interno in frassino tinto nero poro aperto. Disponibile anche modulo con pannello porta tv con contenitore a ribalta, su richiesta può essere dotato di passacavi.

A End support
B Central support
C Module

Montante terminale
Montante centrale
Modulo

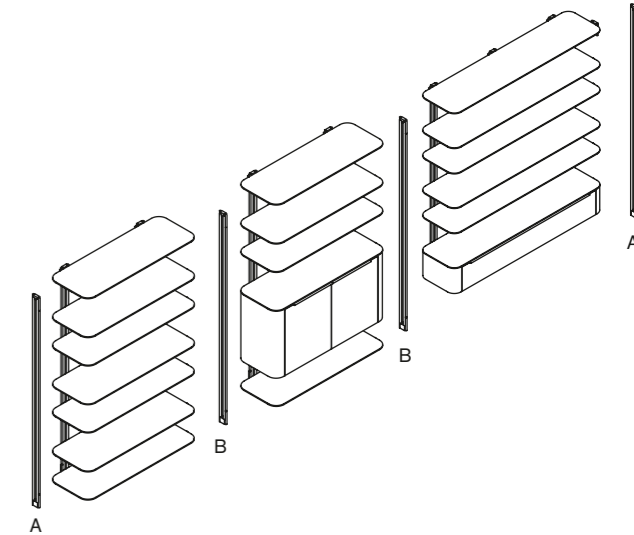

Cm (L x P x H)
Composed by
Composta da
n. 2 module with shelf and drawer moduli con mensole e cassetti
123 x 47 x 194
cod.123-C1-194

Inches (W x D x H)
Composed by
Composta da
n. 2 module with shelf and drawer moduli con mensole e cassetti
48½" x 18¾" x 76½"
cod.123-C1-194

n. 2 module with shelf and doors moduli con mensole e ante
123 x 47 x 194
cod.123-A3-194

n. 2 module with shelf and doors moduli con mensole e ante
48½" x 18¾" x 76½"
cod.123-A3-194

n. 2 end support montanti terminali 194
cod. T194

n. 2 end support montanti terminali 76½
cod. T194

n. 3 central support montanti centrali 194
cod. C194

n. 3 central support montanti centrali 76½
cod. C194

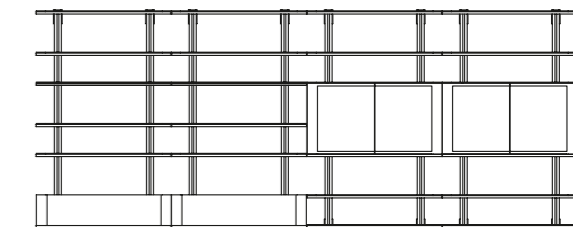

pp. 8, 10, 15

Tortona

Massimo Castagna
2014

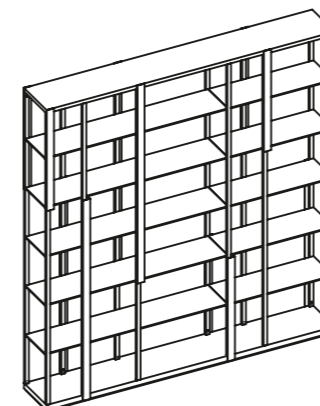

Cm (L x P x H)
166 x 37 x 65
239 x 37 x 65
166 x 37 x 92
239 x 37 x 92
166 x 37 x 175
239 x 37 x 175
166 x 37 x 258
239 x 37 x 258

Inches (W x D x H)
65½" x 14¾" x 25¾"
94¼" x 14¾" x 25¾"
65½" x 14¾" x 36¼"
94¼" x 14¾" x 36¼"
65½" x 14¾" x 69"
94¼" x 14¾" x 69"
65½" x 14¾" x 101¼"
94¼" x 14¾" x 101¼"

Shelving system in patinated bronze lacquered metal. 8mm bronze stopsol or extralight tempered glass shelves. Top also available with recessed Calacatta Vagli Oro marble (only for the versions 65h cm and 92h cm, on request). Not available in custom size.

Libreria in metallo verniciato bronzo patinato. Piani in cristallo 8mm stopsol bronzo o extralight temperato. Su richiesta disponibile top con marmo Calacatta Vagli Oro incassato (solo per le versioni cm 65h e cm 92h). Non realizzabile su misura.

p. 51

Beds Letti

Xeni

Massimo Castagna
2018

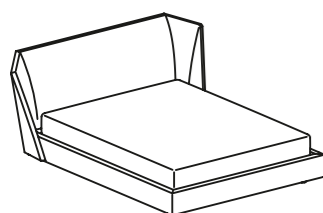

pp. 110, 112

Cm (L×P×H)	Inches (W×D×H)
224 x 244 x 98 (160 x 200)*	88¼" x 96¼" x 38¾" (63" x 78¾")*
244 x 244 x 98 (180 x 200)*	96¼" x 96¼" x 38¾" (71" x 78¾")*
264 x 244 x 98 (200 x 200)*	104" x 96¼" x 38¾" (78¾" x 78¾")*
217 x 247 x 98 (153 x 203)*	85½" x 97¼" x 38¾" (60¼" x 80")*
257 x 247 x 98 (193 x 203)*	101¼" x 97¼" x 38¾" (76" x 80")*
247 x 257 x 98 (183 x 213)*	97¼" x 101¼" x 38¾" (72¼" x 84")*

*Cm (L × P)
Mattress—Materasso

*Inches (W × D)
Mattress—Materasso

Bed in non-deformable foam polyurethane in different density and polyester fibre with wooden inside structure. Available covered by fabric or leather as per sample. Wooden slats included.

Letto in poliuretano espanso indeformabile a densità differenziate e fibra poliestere con struttura interna in legno. Disponibile con rivestimento in tessuto o pelle nei colori di campionario. Rete a doghe inclusa.

Yuki

Massimo Castagna
2019

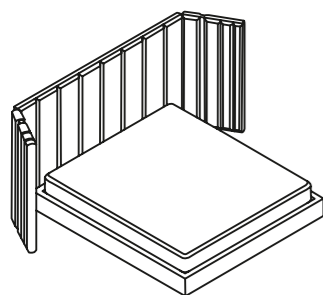

p. 72

Cm (L×P×H)	Inches (W×D×H)
343 x 225 x 135 (160 x 200)*	135¾" x 88¾" x 53¼" (63" x 78¾")*
363 x 225 x 135 (180 x 200)*	143" x 88¾" x 53¼" (71" x 78¾")*
393 x 225 x 135 (200 x 200)*	154¾" x 88¾" x 53¼" (78¾" x 78¾")*
343 x 228 x 135 (153 x 203)*	135¼" x 90" x 53¼" (60¼" x 80")*
393 x 228 x 135 (193 x 203)*	154¾" x 90" x 53¼" (76" x 80")*
363 x 238 x 135 (183 x 213)*	143" x 93¾" x 53¼" (72¼" x 84")*

*Cm (L × P)
Mattress—Materasso

*Inches (W × D)
Mattress—Materasso

Bed in non-deformable foam polyurethane in different density and polyester fibre. Freestanding upholstered headboard with adjustable side panels. Wooden slats included. Available covered by fabric or leather as per sample. Satin brass details. USB charger ports version (one for each side) on request.

Letto imbottito in poliuretano espanso indeformabile a densità differenziate e fibra poliestere. Testata autoportante imbottita con pannelli laterali orientabili. Rete a doghe inclusa. Disponibile con rivestimento in tessuto o pelle nei colori di campionario. Dettagli in ottone satinato o laccato nero opaco. Su richiesta versione con prese USB (una per ogni lato).

Complements Complementi

Leaf Sculpture

Ricardo Bello Dias
2019

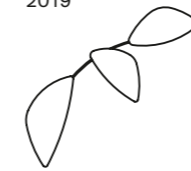

Composition 1



Composition 2

pp. 39, 40, 41

Cm (L×P×H)
Composition 1
215 x 200

Composition 2
180 x 235

Inches (W×D×H)
Composition 1
84¾" x 78¾"

Composition 2
71" x 92¾"

Combinations

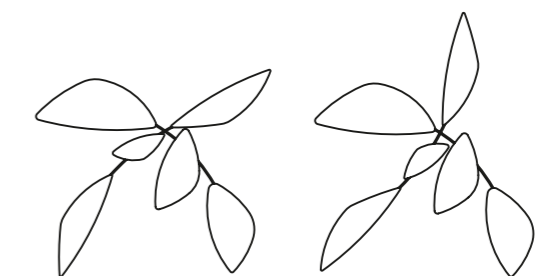

Sculptures in liquidmetal lacquered glass in the colour Lava and Avana. Fixed on panels on different tilts. Available single or as per standard compositions. Burnished metal joint structure.

Sculture in cristallo verniciate nella finitura metallo liquido color Lava e Avana. Montate su pannelli con diverse inclinazioni. Disponibili in composizioni predefinite. Strutture di collegamento in metallo brunito.

Shield

Pietro Russo
2019

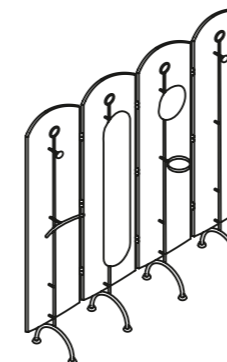

pp. 74, 78, 79

Cm (L×P×H)
204 x 39 x 192

Inches (W×D×H)
80½" x 15½" x 75¾"

Screen composed by 4 curved "Colore" Frisé walnut or Maple Frisé dark grey inlaid wooden modules. Inside in Tanganika white Frisé. Satin brass structure and accessories with 6mm extralight bevelled mirrors.

Paravento composto da 4 moduli in legno curvato intarsiato Noce Colore Frisé o Acero Frisé grigio scuro. Interno in Tanganika bianco Frisé. Struttura e accessori in ottone satinato con specchi 6mm extralight bisellati.

Zeiss

Luca Nichetto
2009



p. 108

Cm (L×P×H)
S 80 x 6 x 78
M 104 x 6 x 92
L 156 x 6 x 151

Inches (W×D×H)
31½" x 2½" x 30¾"
41" x 2½" x 36¼"
61½" x 2½" x 59½"

6mm hand polished and bevelled extralight mirror in three different shapes and sizes. White lacquered wooden frame (thickness 5cm) or lacquered with "fabric" touch effect in the colours chestnut, sand and canapa.

Specchio extralight 6mm molato e bisellato a mano, in tre diverse forme e dimensioni. Cornice in legno (spessore 5cm) laccato bianco oppure effetto tessuto nei colori castagna, sabbia e canapa.

Credits

Graphic design
Studio CCRZ

Photography
Matteo Imbriani
Studio CCRZ

Styling
Elisa Ossino Studio
Studio G&R

Photoengraving
Monogramma

Printing
Grafica Gioia

© 2019
Gallotti&Radice

Instagram



Pinterest



We chat



